

DOOR WIDTH	CLOSER SIZE	CLOSING FORCE in Nm (kpm)	NO HOLD	HOLD OPEN 90°
			PRODUCT CODE	
Up to 750mm	1	20 (2.0)	9601-00-E	9601-90-E
751 to 950mm	2	27 (2.7)	9602-00-E	9602-90-E
951 to 1150mm	3	33 (3.3)	9603-00-E	9603-90-E

SHIPPING WEIGHT 4:46KG

BODY UNIT AND FIXINGS	PRODUCT CODE
DUMMY BODY UNIT	TC-9600-E

SELECT SIZE SMALLER FOR INTERNAL DOORS.  
SELECT SIZE LARGER FOR DOORS IN SEVERE CONDITIONS.

APPLICATIONS  
Double or single action.  
Centre hung offset pivot with special arm.  
Side load and end fittings.  
70mm pivot point.

**CLOSING ADJUSTMENT**

**MAXIMUM DOOR LEAF 100Kgs**

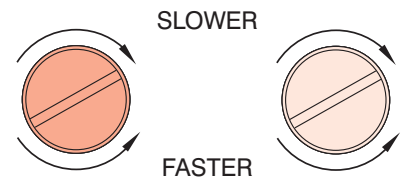
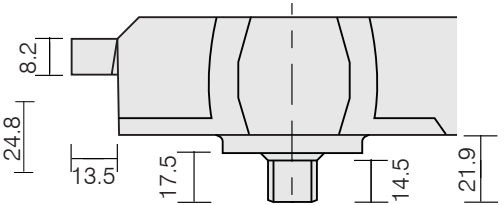
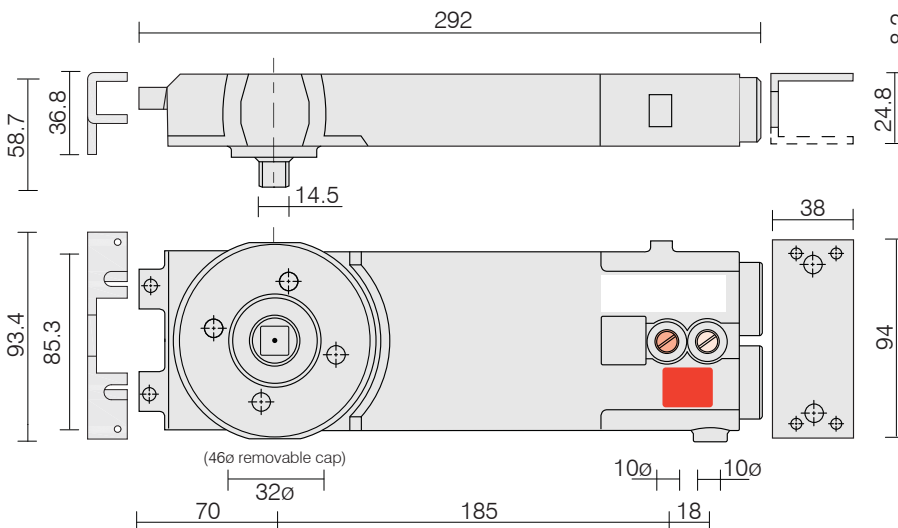
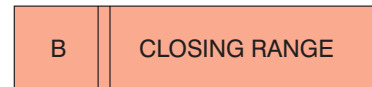
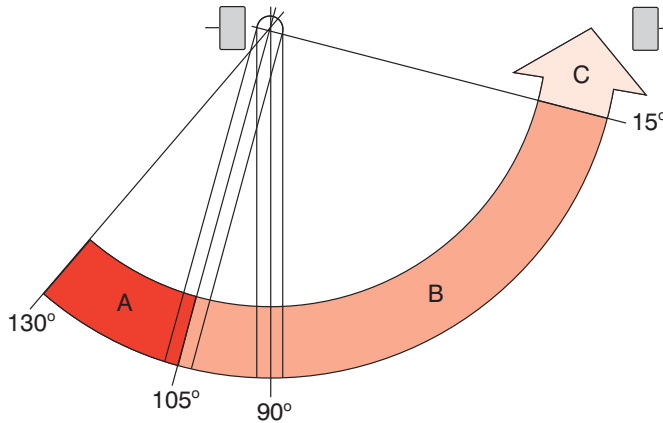

**MAXIMUM TWO TURNS**

**IN EITHER DIRECTION**

**GUARANTEE**

AXIM TRANSOM CLOSERS AND ACCESSORIES ARE GUARANTEED FOR 30 MONTHS FROM THE DATE OF MANUFACTURE AGAINST DEFECT IN MATERIAL AND WORKMANSHIP. THIS GUARANTEE IS VOID IF THE PRODUCT HAS BEEN INCORRECTLY INSTALLED OR DAMAGED IN USE. CLAIMS FOR DAMAGE INCURRED OR WORK DONE THEREON WILL NOT BE ACCEPTED.

AXIM RESERVE THE RIGHT TO UPDATE ITS PRODUCT INFORMATION WITHOUT PRIOR NOTICE



**The Parkside Group Ltd**

The Willow Centre  
17 Willow Lane, Mitcham, Surrey, CR4 4NX  
Tel: 020-8685 9685 Fax: 020-8646 5096  
Email: axim@parksidegroup.co.uk  
Web Site: www.axim.co.uk

SCALE	NTS @A4
DATE	AUGUST 2017

For scaled technical or CAD drawings,  
please contact AXIM.