

**Introduction**

Axim door closers and accessories are guaranteed for a period of 30 months from the date of manufacture against defect in material and workmanship. The guarantee is void if the product has been incorrectly installed or damaged in use. The following notes on maintenance should ensure the closer will operate trouble free for many years.

The set of door controls comprises three main items. Firstly, a sealed unit 'the closer body' which is fitted inside the transom bar above the door and concealed with a removable cover plate. Secondly, a steel drive arm with a steel fixing channel fitted inside the top rail of the door 'the drive arm' which may be side or end loading. Finally the door is supported by a 'bottom pivot assembly'. This consists of a shoe fitted to the underside of the door and a pivot bolt, either fitted to a floor-fixed plate or directly fixed to an aluminium threshold.

**Closer body**

Broadly speaking there are six different closer options with the same external appearance. Closers are fitted with different size internal springs to give light, medium or heavy closing forces. Depending on varying factors such as weather conditions and width and height of the door the correct strength closer should be selected. Closers are also specified 'retention' or 'non-retention'. The former, sometimes referred to as hold-open, hold the door open at 90 degrees whilst the latter, sometimes named no hold-open, will return the door to a closed position regardless of the angle at which it is released. It is important not to wedge the door open as the wedge or stop will oppose the door closer and in time will twist the door.

It is important to realise closers can not be altered in the field and if necessary the closer would require exchanging for an alternative option.

Doors using this type of door closer are generally centre hung and double acting, i.e the door will open in and out unless prevented from doing so by an applied stop. Door closers will open to 130°. Door stops should be fitted to prevent the door striking the jamb or opening past this angle, as damage could occur to the door, frame, and/or closer.

**Removing the door**

Should it be necessary to change the door closer, this is not a difficult job and should take no more than an hour. Tools required:- Small and medium sized pozi head screwdrivers, 4mm and 5mm allen keys and a 10mm open-ended spanner.

Remove the name plate from the internal face of the door to expose the clamp block and fixings. Using an allen key remove the socket head bolts and special lock washers and put to one side. With someone to steady the door from outside, push the door away from the closer spindle, the door may require tapping gently with a soft faced mallet. Once the door is released from the spindle the door can be lifted off the bottom pivot.

Stack the door in a safe place. Remove the M4 screws from the cover plate and prise the cover plate free. The closer body is now visible and reference marks should be noted.

Stamping on the end of the spindle should read N.H.O or H.O.90 referring to the retention option. A number on the circular cover cap will relate to spring power size. A date stamp on the closer body, for example: 35-18 = Week 35, 2018 this will determine if the closer is within the warranty period. If the closer is faulty and still under guarantee please contact your supplier before undertaking any further work.

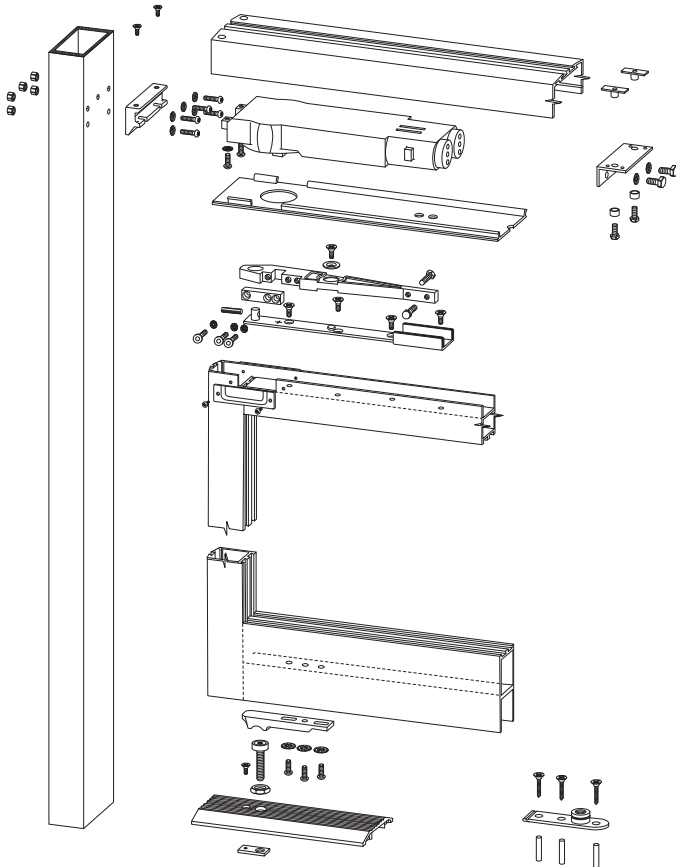

**The Parkside Group Ltd**

The Willow Centre  
17 Willow Lane, Mitcham, Surrey, CR4 4NX  
Tel: 020-8685 9685 Fax: 020-8646 5096  
Email: axim@parksidegroup.co.uk  
Web Site: www.axim.co.uk

SCALE	NTS @A4
DATE	NOVEMBER 2019
For scaled technical or CAD drawings, please contact AXIM.	

**Changing the closer unit**

With a screwdriver loosen the two round head pozi screws connecting the closer to the jamb bracket.

Support the closer and remove the two hexagon head bolts and washers. The closer can now be lowered and removed. Take care not to drop it, the closer weighs 4 Kgs. (8.8lbs.)

Whilst the closer is removed check the fixings in the jamb bracket and tighten securely if loose. Check the steel angle bracket is secure within the header bar. Examine the pivot bearing in the threshold or floor plate, the bearing should be able to rotate freely and the 1/2" bolt should be secure.

To replace the closer reverse the removal procedure and ensure the clamp block screws and lock washers are very tight. If door adjustment is required refer to the section ALIGNMENT.

**Fault diagnosis**

**The following notes should enable a competent maintenance manager to rectify any problems that might occur. If in any doubt please contact the manufacturer as the wrong action could invalidate the warranty.**

**1) The door does not centre firmly but swings freely perhaps for a centimetre either side of the closer position. This is usually due to the clamp block not being fully tightened.**

Remove the small aluminium name plate from the door to expose the clamp block and screws. With an allen key wind in the two or three screws, depending on the arm type, very tightly. Refit the name plate.

**2) The door does not centre firmly as in item 1) and has even more free play.**

It is possible the clamp block has been too loose for too long and the closer spindle has worn if this is the case carry out the remedy as in item 1). If the problem persists the closer and/or top drive arm in the door will need replacing. Note this is not a fault of the closer or accessories but is due to indifferent installation.

**3) The door comes to rest firmly but is up to 25mm off centre.**

Procure a step ladder, or other means, enabling you to look down on to the top rail of the door. Loosen the hold-down, countersunk screw, securing the top arm, with an allen key. Adjust the hexagon bolts against the sides of the steel channel until the door centres in the correct position. Tighten the hold-down screw and check other fixings.

**4) The door drags on the floor/threshold or rubs on the underside of the transom.**

Procure a step ladder, or other means, enabling you to look down on to the top rail of the door. Loosen the hold-down, countersunk screw, securing the top arm, with an allen key and loosen off the hexagon bolts slightly.

a) Standard top arm type:

With the door open use a flat bladed screwdriver to turn the screw clockwise, lifting the door or anticlockwise lowering the door.

b) End load arm or special side loading:

Loosen the locknut against the upstand of the channel and turn the socket head screw with an allen key, clockwise, lifting the door or anticlockwise lowering the door. Tighten the hold-down screw and check other fixings.

**5) The door moves loosely off centre apparently out of control.**

The closer has been forced and strained for some reason and the internal parts have been damaged. The closer will need replacing.

**6) Oil leaking.**

Before despatch each closer is subjected to stringent tests to ensure against leaking. If oil appears to be leaking from the closer try to pin point the source. If leaking from around the spindle the seal may be damaged. If leaking from around one of the valve screws the same could apply. Providing the closer is within the warranty period and has not been subjected to misuse it will be replaced.



The Parkside Group Ltd

The Willow Centre  
17 Willow Lane, Mitcham, Surrey, CR4 4NX  
Tel: 020-8685 9685 Fax: 020-8646 5096  
Email: axim@parksidegroup.co.uk  
Web Site: www.axim.co.uk

SCALE	NTS @A4
DATE	MARCH 2014
For scaled technical or CAD drawings, please contact AXIM.	



TITLE	<b>CONCEALED OVERHEAD TRANSOM CLOSERS</b>	SHEET No. <b>1:15</b>
SUB TITLE	<b>TECHNICAL SUPPORT</b>	

### Six monthly maintenance

Detach the door as previously described, remove the coverplate and expose the closer. Tighten all fixing screws and bolts. Inspect the floor bearing and wipe away any debris, check the bearing rotates freely and the bolt is secured firmly in the plate or threshold. Lubricate with grease if necessary. Tighten all fixings, including the three screws to the bottom rail of the door securing the pivot shoe. Replace the coverplate and remount the door. Tighten all the top arm fixings, particularly the clamp block screws and centre locking screw. Replace the name plate and clean down the door as per finishers recommendations.

### Closing speed adjustment

Providing the closing and final latching speeds of the door closer have been correctly set on installation it should not be necessary to readjust at a later date. However, after the door closer has completed a short settling in period, minor adjustments may be required. It should be noted that inexperienced tampering with the valve screws would cause irreparable damage. The following notes will enable the operator to make simple adjustments – if in any doubt please seek advise from the manufacturer.

It is important to realise that the two valve screws will adjust the closing and latching speeds of the door closer, they will not adjust the closing or opening forces in any way. It is very likely the door closer will require only very minor adjustment, perhaps only one half turn of the valve screw. After any adjustment the door closing speed should be checked twice, by opening the door fully and allowing it to close, before proceeding.

Care must be taken not to unscrew the valve head beyond the level of the closer body when increasing the closing speed. Turning the valve past this limit will allow oil to escape and the closer will need to be replaced. On the other hand if the valve is turned clockwise, decreasing the closing speed, adjustment must cease when resistance is felt as will be damaged along with the oil seal if excessive force is used.



## The Parkside Group Ltd

The Willow Centre  
17 Willow Lane, Mitcham, Surrey, CR4 4NX  
Tel: 020-8685 9685 Fax: 020-8646 5096  
Email: [axim@parksidegroup.co.uk](mailto:axim@parksidegroup.co.uk)  
Web Site: [www.axim.co.uk](http://www.axim.co.uk)

SCALE	NTS @A4
DATE	MARCH 2014
For scaled technical or CAD drawings, please contact AXIM.	