

The Parkside Group Ltd

The Willow Centre
17 Willow Lane, Mitcham, Surrey, CR4 4NX
Tel: 020-8685 9685 Fax: 020-8646 5096
Email: axim@parksidegroup.co.uk
Web Site: www.axim.co.uk

SCALE	NTS @A4
DATE	MARCH 2014

For scaled technical or CAD drawings, please contact AXIM.

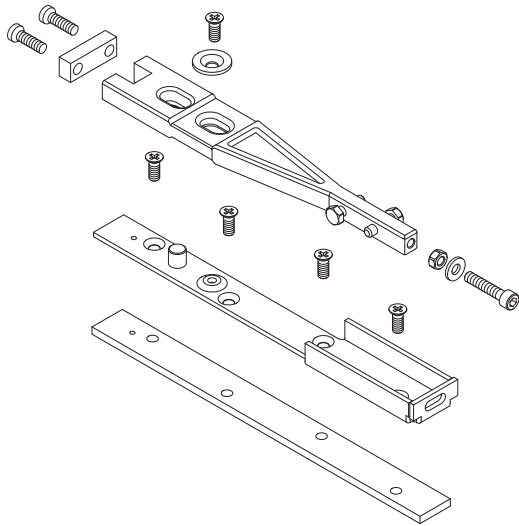

End load top arm & spacer bar TC-8800-15

For use on end loading and anti-finger trap doors.
When using standard door rails spacer bar is not required.

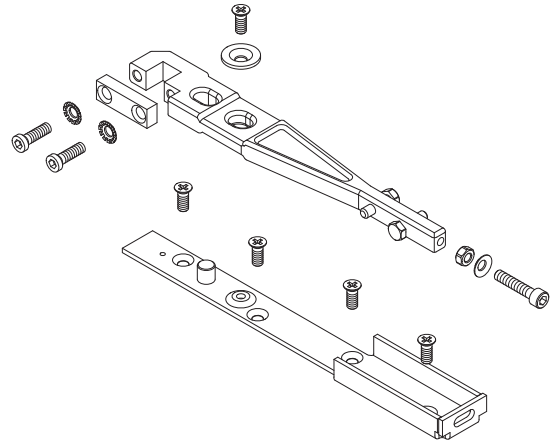
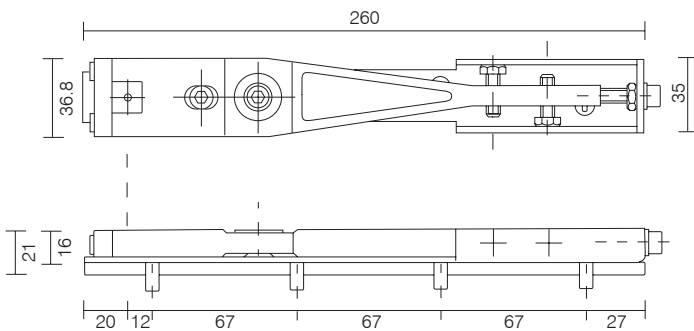

Std. top side load arm TC-8800-13

For use on side loading and anti-finger trap doors.

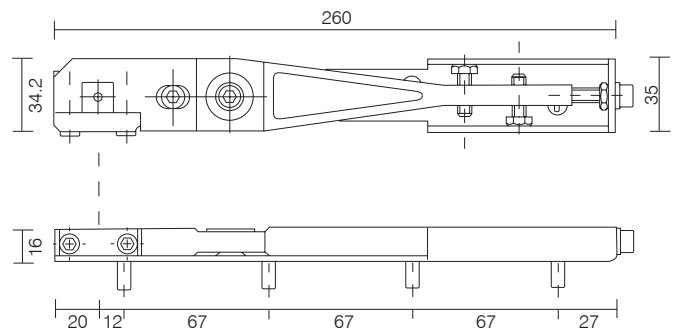

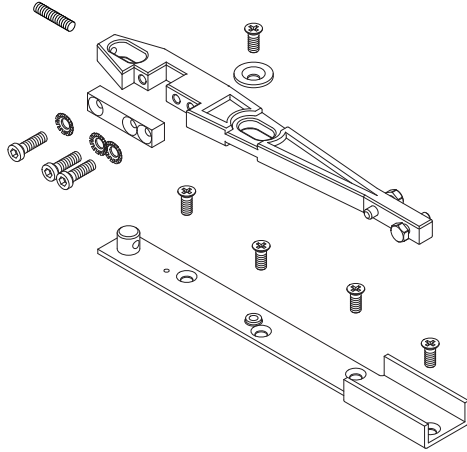

Top side load arm TC-8800-T13
For use on side loading doors.
(Arm supplied with standard transom closer kit)

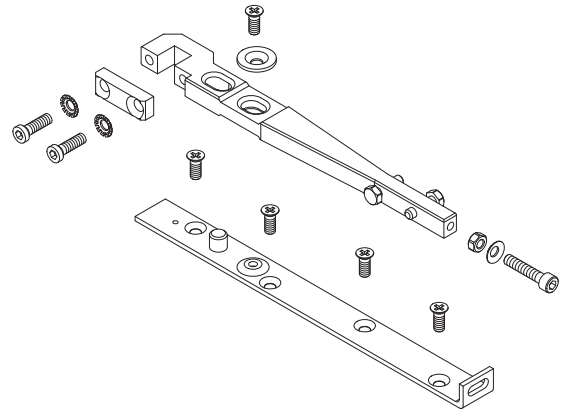
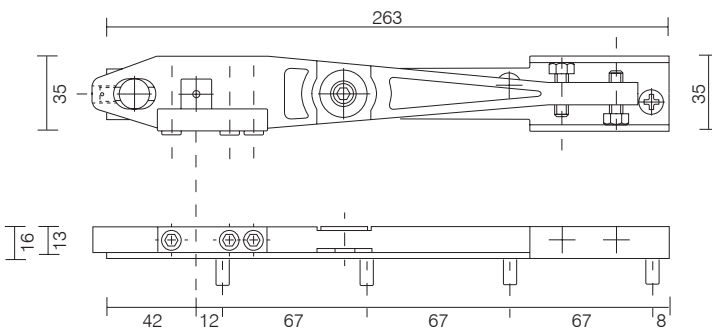

Universal arm TC-8800-01
For use on side loading and armour glass doors

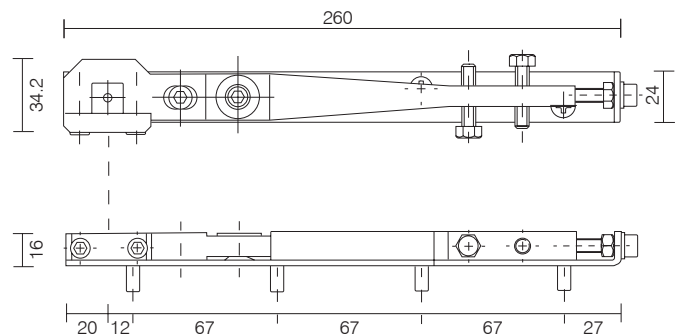

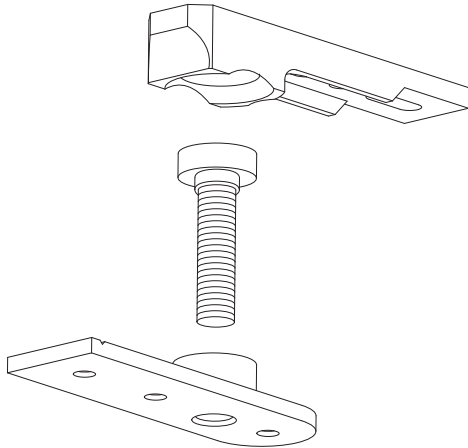

Std bottom pivot assembly
TC-8800-02

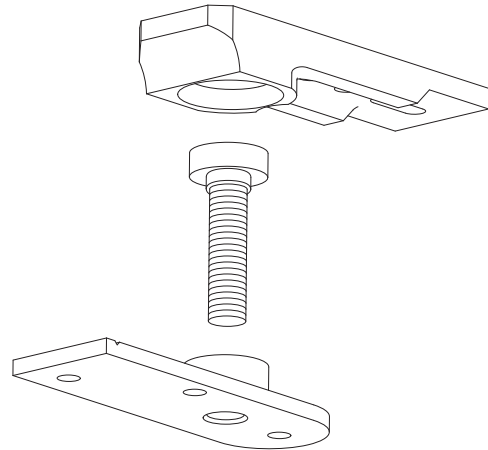

Heavy duty bottom pivot assembly
TC-9500-17. Used with anti finger-trap doors

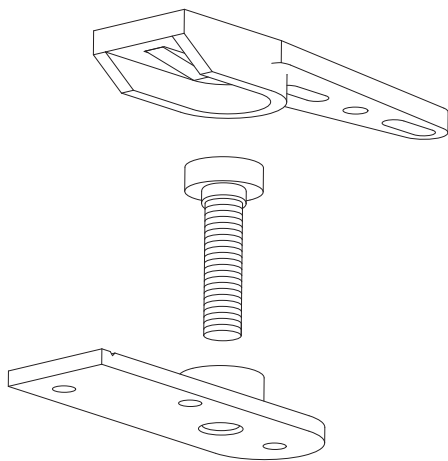

End load bottom pivot assembly
TC-8800-14

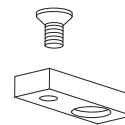

Alternative bottom bearing plate for use with
thresholds supplied as standard with all bottom
pivot assemblies



TITLE	VERSATILE CONCEALED OVERHEAD TC-8800-20 SERIES TRANSOM CLOSER	SHEET No. 1:07
SUB TITLE	INTENTIONALLY BLANK	

**INTENTIONALLY
BLANK**



The Parkside Group Ltd

The Willow Centre
17 Willow Lane, Mitcham, Surrey, CR4 4NX
Tel: 020-8685 9685 Fax: 020-8646 5096
Email: axim@parksidegroup.co.uk
Web Site: www.axim.co.uk

SCALE	NTS @A4
DATE	NOVEMBER 2019
For scaled technical or CAD drawings, please contact AXIM.	

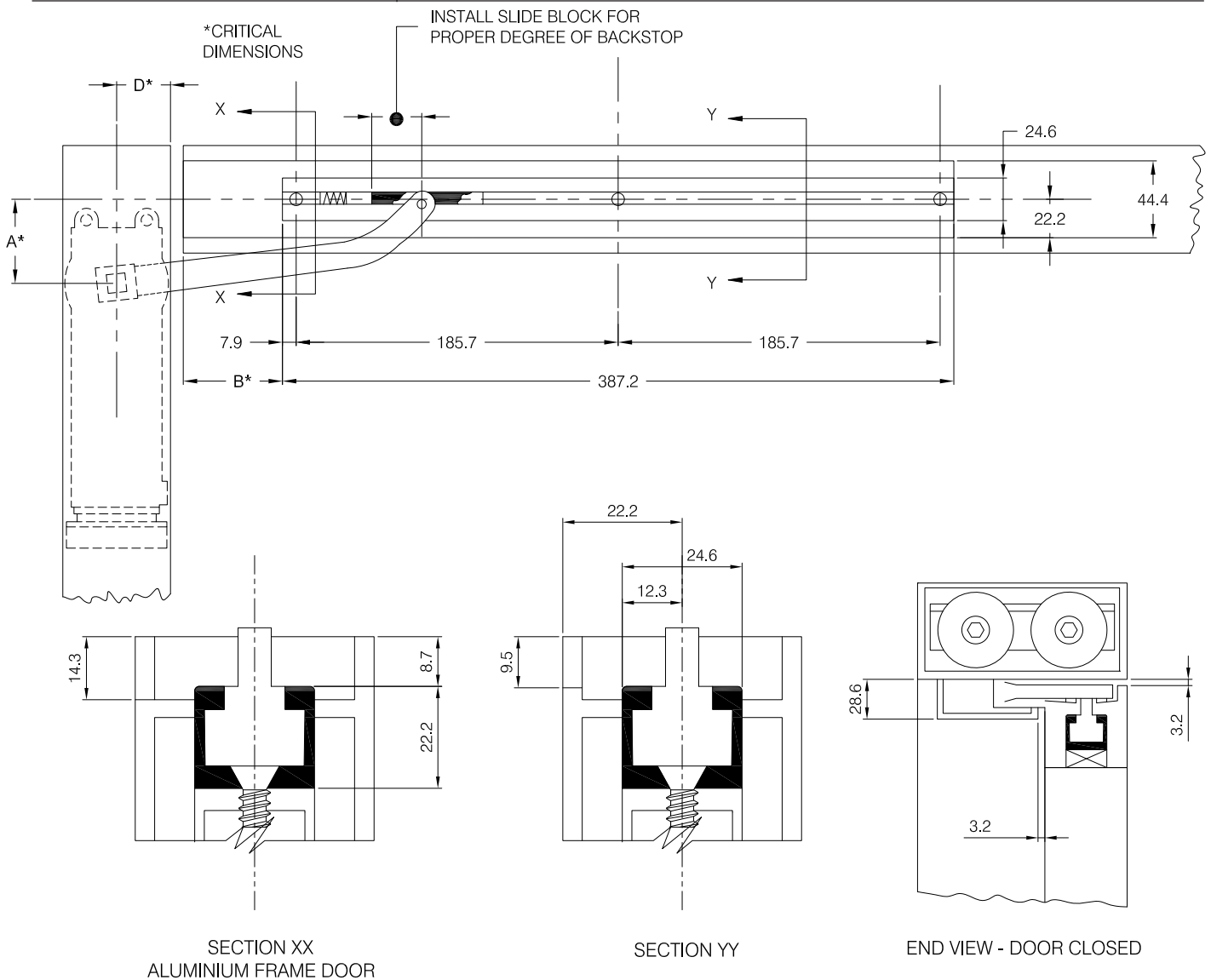

DETERMINE HOW DOOR IS HUNG AND DEGREE OF CLOSER BACKSTOP AND USE APPLICABLE CHART

HEADER PREPARATION:

1. DIMENSION 'A', face of jamb to centre line of spindle must be maintained.
2. DIMENSION 'D', pivot of hinge side of header to centre line of spindle must be maintained regardless of header width.
3. All spacers and/or anchors other than standard 'F' clip package by others.

DOOR PREPARATION:

1. Rout out top rail as shown, for side channel spacers as required by manufacturer.
2. Rout inside face of top rail as shown for arm.
3. Offset pivots or butts by others.

STANDARD BUTT HINGE DOOR MINIMUM 101.6mm HEADER					19.1mm OFFSET PIVOTED DOOR FLUSH DOOR MINIMUM 101.6mm HEADER					15.9 mm OFFSET PIVOTED DOOR 3.2mm RECESSED DOOR MINIMUM 114.3mm HEADER				
Backstop	A (mm)	B (mm)	C (mm)	D (mm)	Backstop	A (mm)	B (mm)	C (mm)	D (mm)	Backstop	A (mm)	B (mm)	C (mm)	D (mm)
105°	95.25	98.4	66.7	50.8	105°	114.3	119.1	85.7	50.8	105°	114.3	119.1	85.7	54.0
90°	73	103.2	44.5	50.8	90°	95.25	125.4	60.3	50.8	90°	95.25	125.4	60.3	54.0



The Parkside Group Ltd

The Willow Centre
17 Willow Lane, Mitcham, Surrey, CR4 4NX
Tel: 020-8685 9685 Fax: 020-8646 5096
Email: axim@parksidegroup.co.uk
Web Site: www.axim.co.uk

SCALE NTS @A4

DATE AUGUST 2017

For scaled technical or CAD drawings,
please contact AXIM.

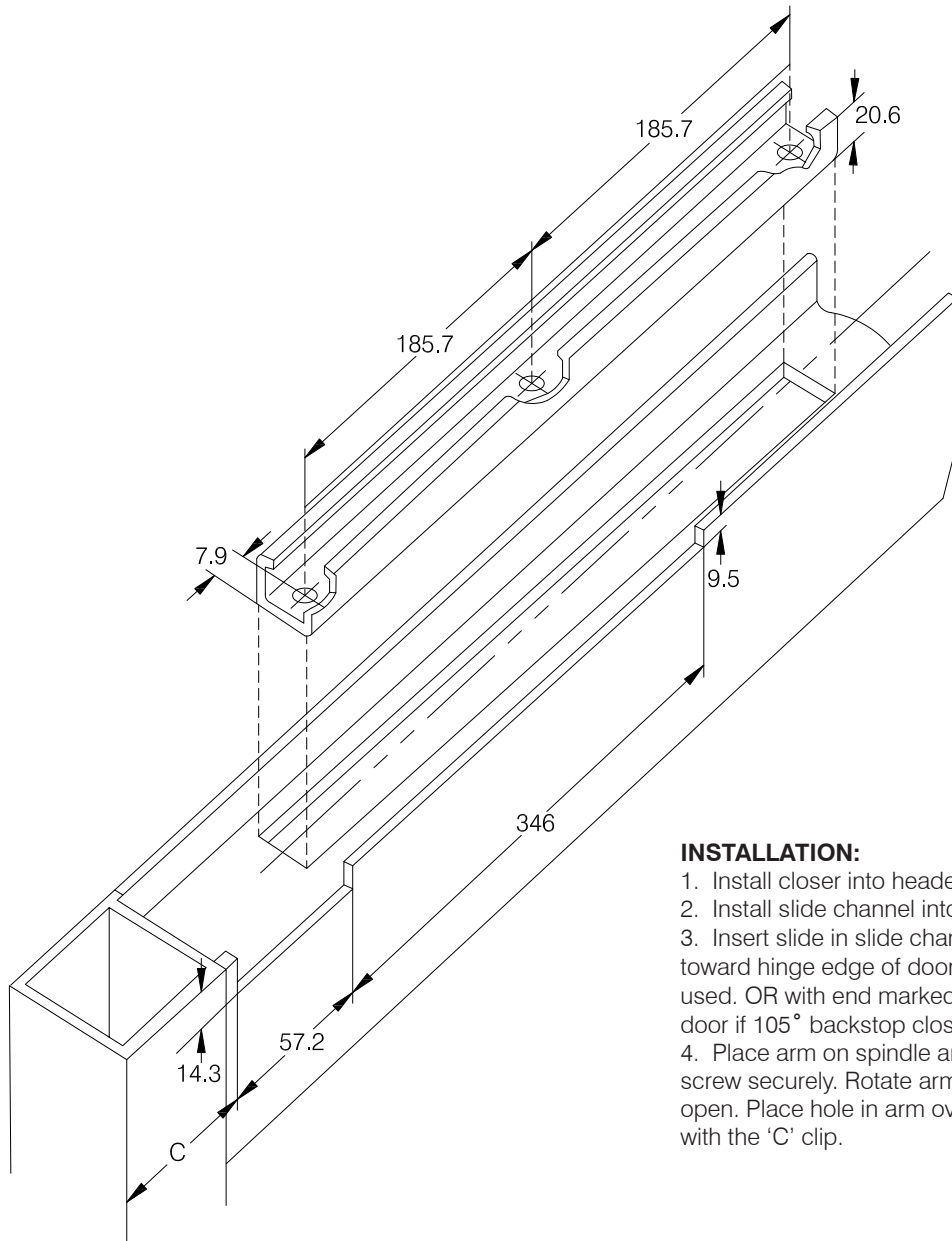

INSTALLATION:

1. Install closer into header.
2. Install slide channel into top rail.
3. Insert slide in slide channel with end marked 90° toward hinge edge of door if 90° backstop closer is used. OR with end marked 105° toward hinge edge of door if 105° backstop closer is used.
4. Place arm on spindle and tighten 1/4"-20 socket head screw securely. Rotate arm from centre as if door were open. Place hole in arm over pin in the slide and secure with the 'C' clip.