

L.H.R.B. Door shown

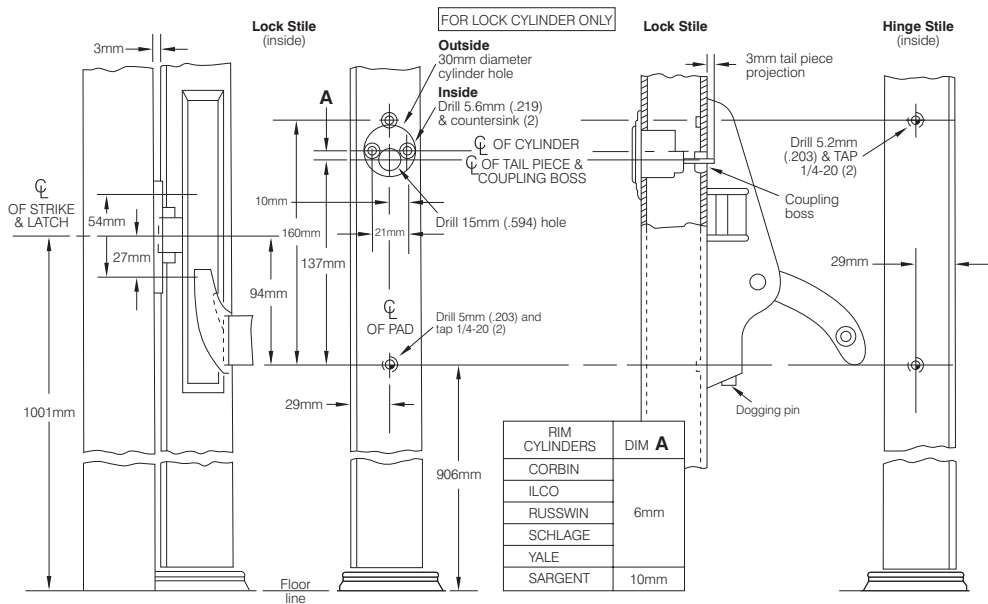
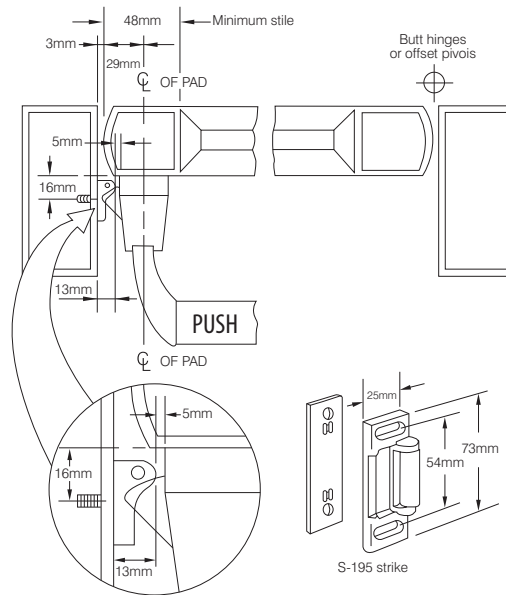

Preparation

1. Determine hand of door and prepare inside of lock and hinge stiles as shown.
2. If cylinder Key Lock is to be used, prepare inside and outside of lock stile as shown.
 - A Cut Spindle of Rim Cylinder to project thru the door 3mm Install Rim Cylinder and secure with (2) 12-24x29mm Machine Screws NOTE: Screw heads must be flush.
 - B Determine Function of Key Cylinder:
 - (1) STANDARD: Key removable in either locked or unlocked position. With Latch fully released, rotate Coupling Boss so index mark is up.
 - (2) NIGHT LATCH: Key removable in locked position only. With latch fully released, rotate Coupling Boss 90° towards hinge side.

3. Install (2) 1/4-20 Shoulder Studs on lock stile and position Exit Latch Pad over Studs and insert Cylinder Spindle into Coupling Boss. Place Pad over Studs and tighten 3 Socket Head Set Screws to secure in place.
4. Prepare lock jamb for Strike as shown and install using (2) #10 x 13mm Flat Head Self-threading Screws or #10 x 32mm All-purpose Screws.

DOGGING EXIT DEVICE USING DOGGING PIN:
Fully depress Cross Bar and hold, push up Dogging Pin with screwdriver and rotate 90° in either direction.

TO RELEASE EXIT DEVICE:
Hold Cross Bar down and rotate Dogging Pin with screwdriver in either direction until Dogging Pin releases.

DOGGING EXIT DEVICE USING CYLINDER KEY:
Turn Key toward hinge side approximately 360°.

TO RELEASE EXIT DEVICE:
Turn Key toward latch side approximately 360°.



The Parkside Group Ltd

The Willow Centre
17 Willow Lane, Mitcham, Surrey, CR4 4NX
Tel: 020-8685 9685 Fax: 020-8646 5096
Email: axim@parksidegroup.co.uk
Web Site: www.axim.co.uk

SCALE	NTS @A4
DATE	MARCH 2014
For scaled technical or CAD drawings, please contact AXIM.	

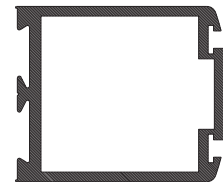

RC-795-AL Rim cylinder for use with 7095P panic exit device

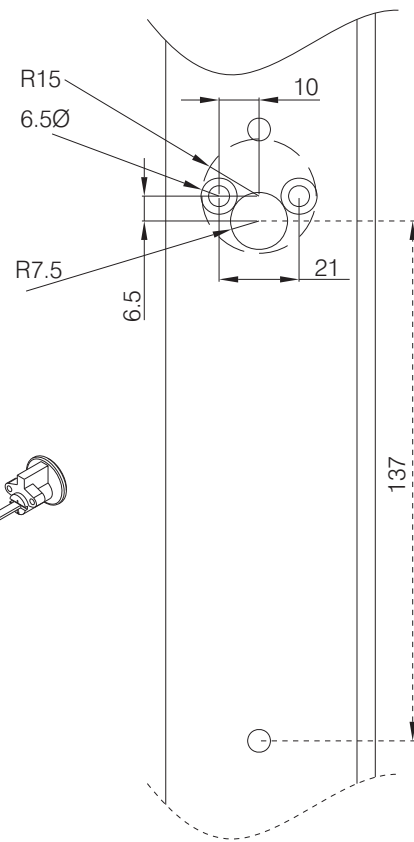
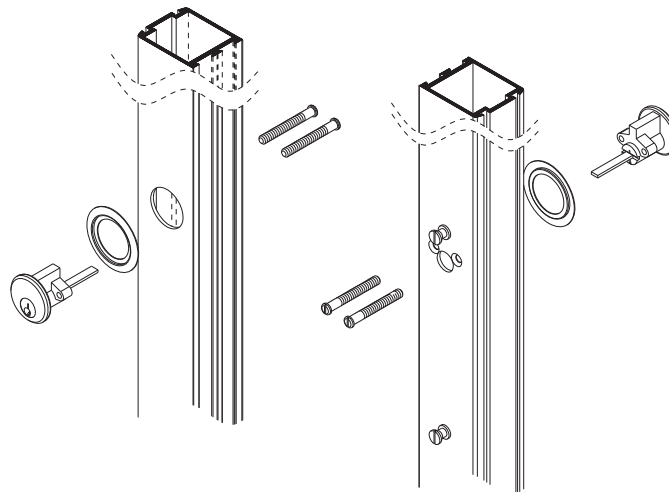

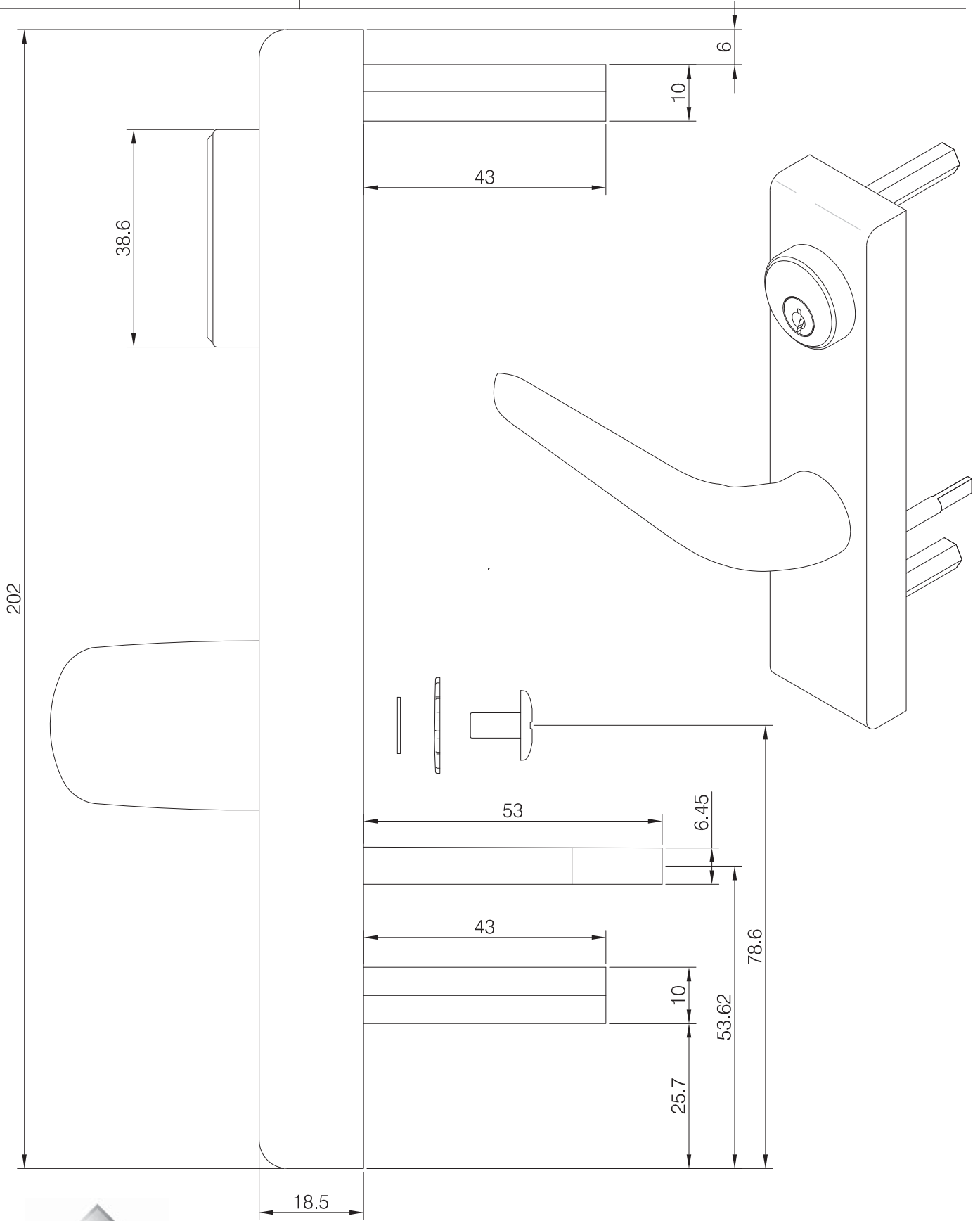

The Parkside Group Ltd

The Willow Centre
17 Willow Lane, Mitcham, Surrey, CR4 4NX
Tel: 020-8685 9685 Fax: 020-8646 5096
Email: axim@parksidegroup.co.uk
Web Site: www.axim.co.uk

SCALE	NTS @A4
DATE	JULY 2017

For scaled technical or CAD drawings, please contact AXIM.

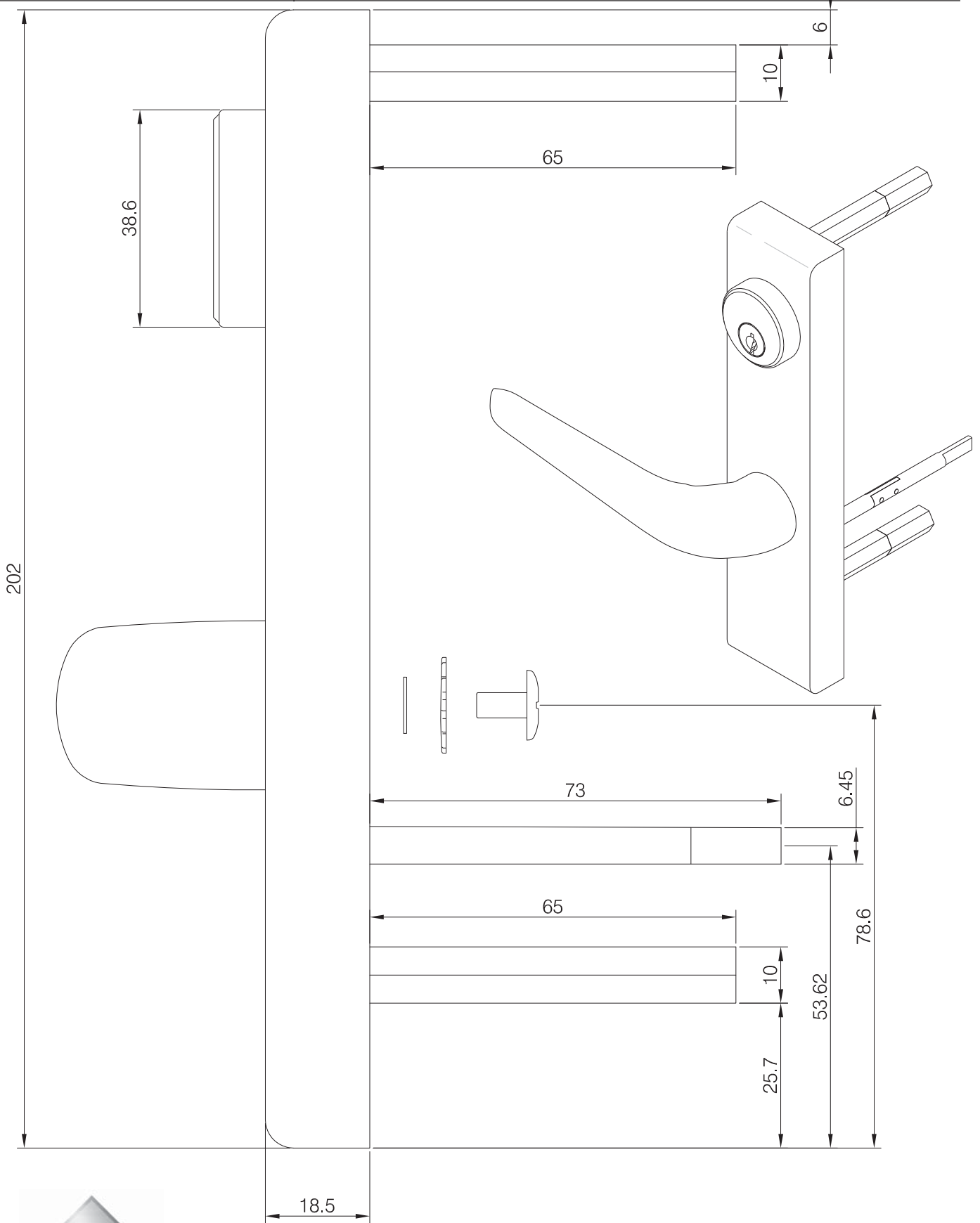

The Parkside Group Ltd
 The Willow Centre
 17 Willow Lane, Mitcham, Surrey, CR4 4NX
 Tel: 020-8685 9685 Fax: 020-8646 5096
 Email: axim@parksidegroup.co.uk
 Web Site: www.axim.co.uk

SCALE	NTS @A4
DATE	JULY 2017
For scaled technical or CAD drawings, please contact AXIM.	