

**HAND OF DOOR**

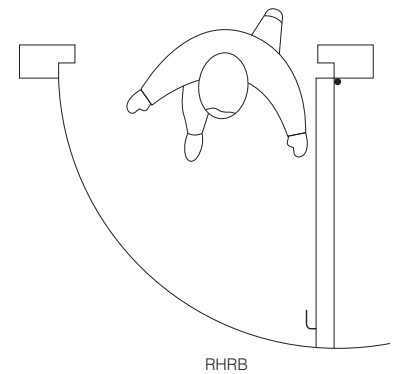
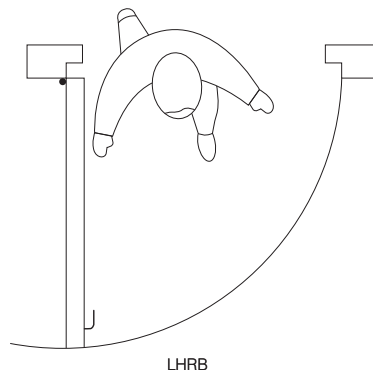

**RIM MOUNTED, PANIC EXIT DEVICE**

Matching active and in-active housings to present a balanced appearance. Housings assembled to be right or left handed. Please check handing and specify when ordering.  
Heavy duty lever springs for durable operation of lever arms.  
Hardened latch bolt for added security.  
Narrow width, surface mounted strike supplied, adjustable after installation.  
Standard model suitable for doors of up to 1155mm wide.  
1500mm long crossbars available for extra wide doors. Cross bars can be cut to suit exact requirement.  
Available with standard rim cylinder that can be fitted directly to the door allowing operation from the outside.  
Permanent latch retention by either cylinder key from outside or concealed pins under levers.  
Anodised crossbars in:-  
Silver Satin, Dark Bronze & Black.  
Housings and lever arms stoved, abrasive resistant finish to match anodised finishes.  
Easy to follow instructions and full size templates supplied with every unit.

**ACCESSORIES**

Rim cylinder for access from outside. (2 keys.)  
**RC-795-AL** - 46mm to 54mm DOOR STILE - Silver  
**RC-795-DU** - 46mm to 54mm DOOR STILE - Bronze  
**RC-795-BK** - 46mm to 54mm DOOR STILE - Black  
**RC-795-AL-S** - 46mm to 54mm DOOR STILE - Silver  
**RC-797-AL** - 46mm to 67mm DOOR STILE - Silver  
**RC-797-AL-S** - 46mm to 67mm DOOR STILE - Silver

Push bar, 1500mm. For wide doors cut to suit.  
**CB-742-AL** - 1066.8mm - CRASH BAR - Silver  
**CB-748-AL** - 1219.2mm - CRASH BAR - Silver  
**CB-760-AL** - 1524mm - CRASH BAR - Silver  
Other finishes available to special order.

**Paddle handle**

**PR-7095-AL-L** - Left hand - Silver  
**PR-7095-AL-R** - Right hand - Silver  
**PR-7095-P-AL-LH** - Left hand - Silver  
**PR-7095-P-AL-RH** - Right hand - Silver  
Other finishes available to special order.

**GUARANTEE**

AXIM HANDLES ARE GUARANTEED FOR 12 MONTHS AGAINST DEFECT IN MATERIAL AND WORKMANSHIP. THIS GUARANTEE IS VOID IF THE PRODUCT HAS BEEN INCORRECTLY INSTALLED OR DAMAGED IN USE. CLAIMS FOR DAMAGE INCURRED OR WORK DONE THEREON WILL NOT BE ACCEPTED.  
AXIM RESERVE THE RIGHT TO UPDATE ITS PRODUCT SPECIFICATIONS WITHOUT PRIOR NOTICE.



**The Parkside Group Ltd**

The Willow Centre  
17 Willow Lane, Mitcham, Surrey, CR4 4NX  
Tel: 020-8685 9685 Fax: 020-8646 5096  
Email: axim@parksidegroup.co.uk  
Web Site: www.axim.co.uk

SCALE	NTS @A4
DATE	JULY 2017
For scaled technical or CAD drawings, please contact AXIM.	