

Panic exit device:
PR-7300-AL - 42" flat touch bar (non handed) - Silver

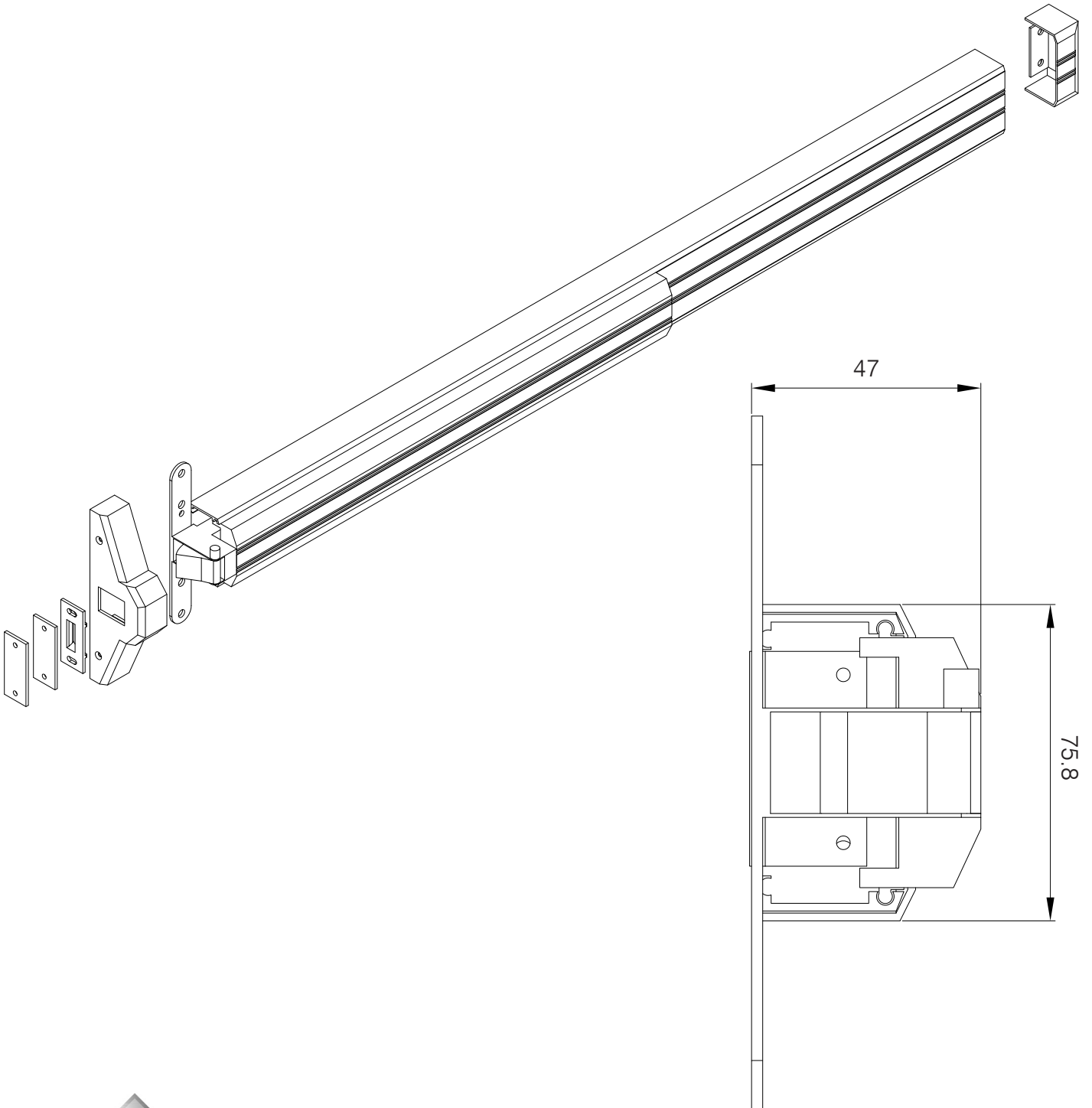

The Parkside Group Ltd

The Willow Centre
17 Willow Lane, Mitcham, Surrey, CR4 4NX
Tel: 020-8685 9685 Fax: 020-8646 5096
Email: axim@parksidegroup.co.uk
Web Site: www.axim.co.uk

SCALE	NTS @A4
DATE	FEBRUARY 2023

For scaled technical or CAD drawings,
please contact AXIM.

**HOLLOW METAL DOORS – WITH REINFORCEMENT
INSTALLATION INSTRUCTIONS**

- Determine hand of door and prepare inside face of Lock and Hinge Side as shown.
- NOTE: For Key Cylinder Only**
If key cylinder is to be used, prepare inside and outside face of Lock Stile of door as shown. Cut spindle of Rim Cylinder to project thru the door 4mm. Install Rim Cylinder and secure with (2) 12-24 Fillister Head Machine Screws.
NOTE: Cut off excess Screw length at break-off points as required.
- Measure for correct Panic length. Measure distance from centreline of mounting holes on Lock and Hinge side of door as indicated AND ADD 22.2mm. Mark the measurement on back of the Panic from Latch End towards the Hinge End to be cut. Stuff a rag in the end of the Back Channel prior to cutting off excess length so that metal chips will not get into the mechanism. Protect the area to be cut and then cut to correct length.
- Drill (2) clearance holes for 12-24 Machine Screws and Hinge End of Back Channel as indicated. Attach Hinge End of Panic and Hinge End Mounting Bracket LOOSLEY on Hinge Side with (2) 12-24*25.4mm Pan Head Thread Cutting Machine Screws and Lock Washers or (2)#12*31.8mm Pan Head All-Purpose Screws and Lock Washers.
- Install (2) 1/4-20 Shoulder Studs on Lock Side. Position Latch End of Panic over Hex Mounting Studs. Secure with (2) 1/4-20 Hex Nuts and Lock Washers; also with (4) 12-24*25.4mm Pan Head Thread Cutting Machine Screws and Lock Washers or (4) 12-24*25.4mm Pan Head All-Purpose

Screws and Lock Washers. Tighten the (2) screws on the Hinge End Mounting Bracket.

NOTE: If Key Cylinder is used, Cylinder Spindle must be inserted into Coupling Boss prior to fastening Latch End on door.



- Attach Latch End Cover and Hinge End Cover with (4) 8-32*12.7mm Flat Head Thread Cutting Machine Screws.
- Place Strike on Lock Jamb as shown, (Centred on Latch). Mark and Drill Jamb for (2) 10-24*19.1mm Pan Head Thread Cutting Machine Screws and Lock Washers or (2)#10*31.8mm Pan Head All Purpose Screws and Lock Washers.
- Position Latch End of Panic over Hex Mounting Studs, Secure Latch End of Panic with (2) 1/4-20 Hex Nuts and Lock Washers, Tighten the (2) screws on the Hinge End Mounting Bracket, put crank into Latch End Housing, making sure that Link fits over end pin, insert screw into crank and tighten.
- Attach Latch End Cover and Hinge End Cover with (4)8-32*12.7mm Flat Head Thread Cutting Machine Screws.
NOTE: Use Spacers provided if required.

**HOLLOW METAL AND WOOD DOORS – WITHOUT REINFORCEMENT
INSTALLATION INSTRUCTIONS**

- Determine hand of door and prepare inside face of Lock and Hinge Side as shown.
- NOTE: For Key Cylinder Only**
If key cylinder is to be used, prepare inside and outside face of Lock Stile of door as shown. Cut spindle of Rim Cylinder to project thru the door 4mm. Install Rim Cylinder and secure with (2) 12-24 Fillister Head Machine Screws.
NOTE: Cut off excess Screw length at break-off points as required.
- Measure for correct Panic length. Measure distance from centreline of mounting holes on Lock and Hinge Side of door as indicated AND ADD 22.2mm. Mark the measurement on the back of the Panic from Latch End towards the Hinge End to be cut. Stuff a rag in the end of the Back Channel prior to cutting off excess length so that metal chips will not get into the mechanism. Protect the area to be cut and then cut to correct length.
- Drill (2) clearance holes for 12-24 Machine Screws in Hinge End of Back Channel as indicated. Attach Hinge End of Panic and Hinge End Mounting Bracket LOOSLEY on Hinge side with (2) 12-24*25.4mm Pan Head Thread Cutting Machine Screws

and Lock Washers with 12-24*42.9mm Sex Nuts or (2)#12*31.8mm Pan Head All-Purpose Screws and Lock Washers.

- Install (2) 1/4-20 Shoulder Studs on Lock Stile. Position Latch End of Panic over Hex Mounting Studs. Secure with (2) 1/4-20 Hex Nuts and Lock Washers; also with (4) 12-24*25.4mm Pan Head Thread Cutting Machine Screws and Lock Washers with 12-24*42.9mm Sex Nuts or (4)#12*31.8mm Pan Head All-Purpose Screws and Lock Washers. Tighten the (2) screws on the Hinge End Mounting Bracket.

NOTE: If Key Cylinder is used, Cylinder Spindle must be inserted into Coupling Boss prior to fastening Latch End on door.



- Attach Latch End Cover and Hinge End Cover with (4) 8-32*12.7mm Flat Head Thread Cutting Machine Screws.
- Place Strike on Lock Jamb as shown, (Centred on Latch). Mark and Drill Jamb for (2) 10-24*19.1mm Pan Head Thread Cutting Machine Screws and Lock Washers or (2)#10*31.8mm Pan Head All Purpose Screws and Lock Washers.
NOTE: Use Spacers provided if required.

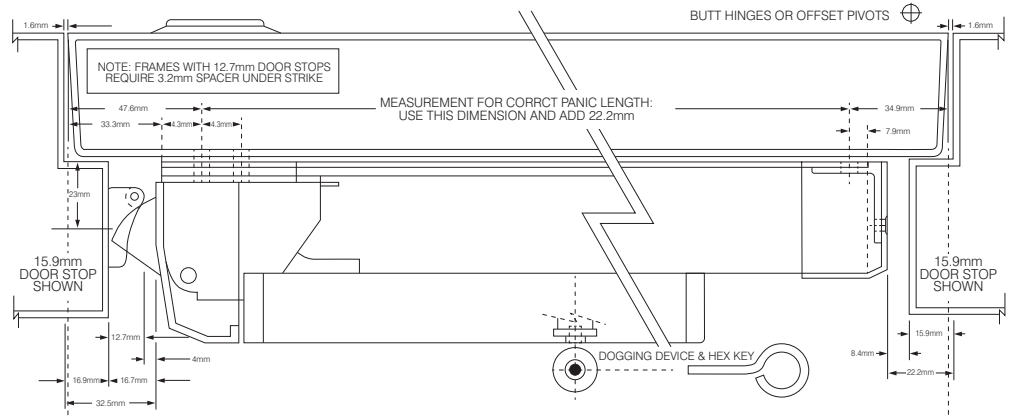

OPERATING INSTRUCTIONS

TO UNLOCK DOOR USING CYLINDER KEY:

Turn key approximately 1/4 turn in either direction and open door, return key to centre and remove. **NOTE:** Cylinder Key WILL NOT dog unit. Dogging is from inside with Hex Dogging Key only.

DOGGING USING DOGGING KEY:

Fully depress Touch Bar and hold. Using Hex Dogging Key **push in** Dogging Device and turn **clockwise** approximately 1/2 turn.

TO RELEASE DOGGING KEY DOGGING:

Hold Touch Bar down. Using Hex Dogging Key **push in** Dogging Device and turn **counterclockwise** approximately 1/2 turn. Dogging will be released.

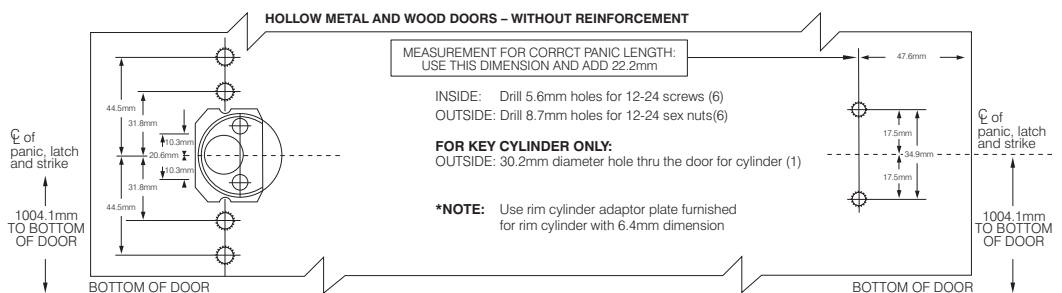
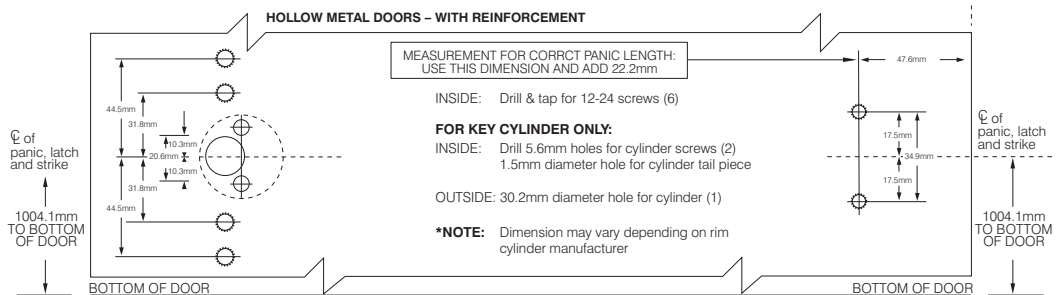

The Parkside Group Ltd

The Willow Centre
17 Willow Lane, Mitcham, Surrey, CR4 4NX
Tel: 020-8685 9685 Fax: 020-8646 5096
Email: axim@parksidegroup.co.uk
Web Site: www.axim.co.uk

SCALE	NTS @A4
DATE	MARCH 2014
For scaled technical or CAD drawings, please contact AXIM.	

INSTALLATION INSTRUCTIONS

- Determine hand of door and prepare inside face of Lock and Hinge Stile as shown.
- NOTE: For Key Cylinder Only**
If key cylinder is to be used, prepare inside and outside face of Lock Stile as shown. Cut spindle of Rim Cylinder to project thru the door 4mm. Install Rim Cylinder and secure with (2) 12-24 Fillister Head Machine Screws.
NOTE: Cut off excess Screw length at break-off points as required.
- Measure for correct Panic length. Measure distance from centreline of mounting holes on Lock and Hinge Stiles of door as indicated AND ADD 22.2mm. Mark the measurement on the back of the Panic from Latch End towards the Hinge End to be cut. Stuff a rag in the end of the Back Channel prior to cutting off excess length so that metal chips will not get into the mechanism. Protect the area to be cut and then cut to correct length.
- Drill (2) clearance holes for 12-24 Machine Screws in Hinge End of Back Channel as indicated. Attach Hinge End of Panic and Hinge End Mounting Brack LOOSLEY on Hinge Stile with (2) 12-24*2525.4mm Pan Head Thread Cutting

- Machine Screws and Lock Washers or (2) #12-24*25.4mm Pan Head All-purpose Screws and Lock Washers.
- Install (2) 1/4-20 Shoulder Studs on Lock Stile. Position Latch End of Panic over Hex Mounting Studs. Secure with (2) 1/4-20 Hex Nuts and Lock Washers; also with (4) 12-24*25.4mm Pan Head Thread Cutting Machine Screws and Lock Washers or (4) #12*31.8mm Pan Head All-Purpose Screws and Lock Washers. Tighten the (2) screws on the Hinge End Mounting Bracket.

NOTE: If Key Cylinder is used, Cylinder Spindle must be inserted into Coupling Boss prior to fastening Latch End on Lock Stile.

- Attach Latch End Cover and Hinge End Cover with (4) 8-32*12.7mm Flat Head Thread Cutting Machine Screws.
- Place Strike on Lock Jamb as shown, (Centred on Latch). Mark and Drill Jamb for (2) 10-24*19.1mm Pan Head Thread Cutting Machine Screws and Lock Washers or (2)#10*31.8mm Pan Head All Purpose Screws and Lock Washers.

NOTE: 3.2mm Spacer must be used under Strike on a Frame. Use extra Spacer provided if required.

OPERATING INSTRUCTIONS

TO UNLOCK DOOR USING CYLINDER KEY:
Turn key approximately 1/4 turn in either direction and open door, return key to centre and remove.
NOTE: Cylinder Key WILL NOT dog unit. Dogging is from inside with Hex Dogging Key only.

DOGGING USING DOGGING KEY:

Fully depress Touch Bar and hold. Using Hex Dogging Key **push** in Dogging Device and turn **clockwise** approximately 1/2 turn.

TO RELEASE DOGGING KEY DOGGING:

Hold Touch Bar down. Using Hex Dogging Key **push** in Dogging Device and turn **counterclockwise** approximately 1/2 turn. Dogging will be released.

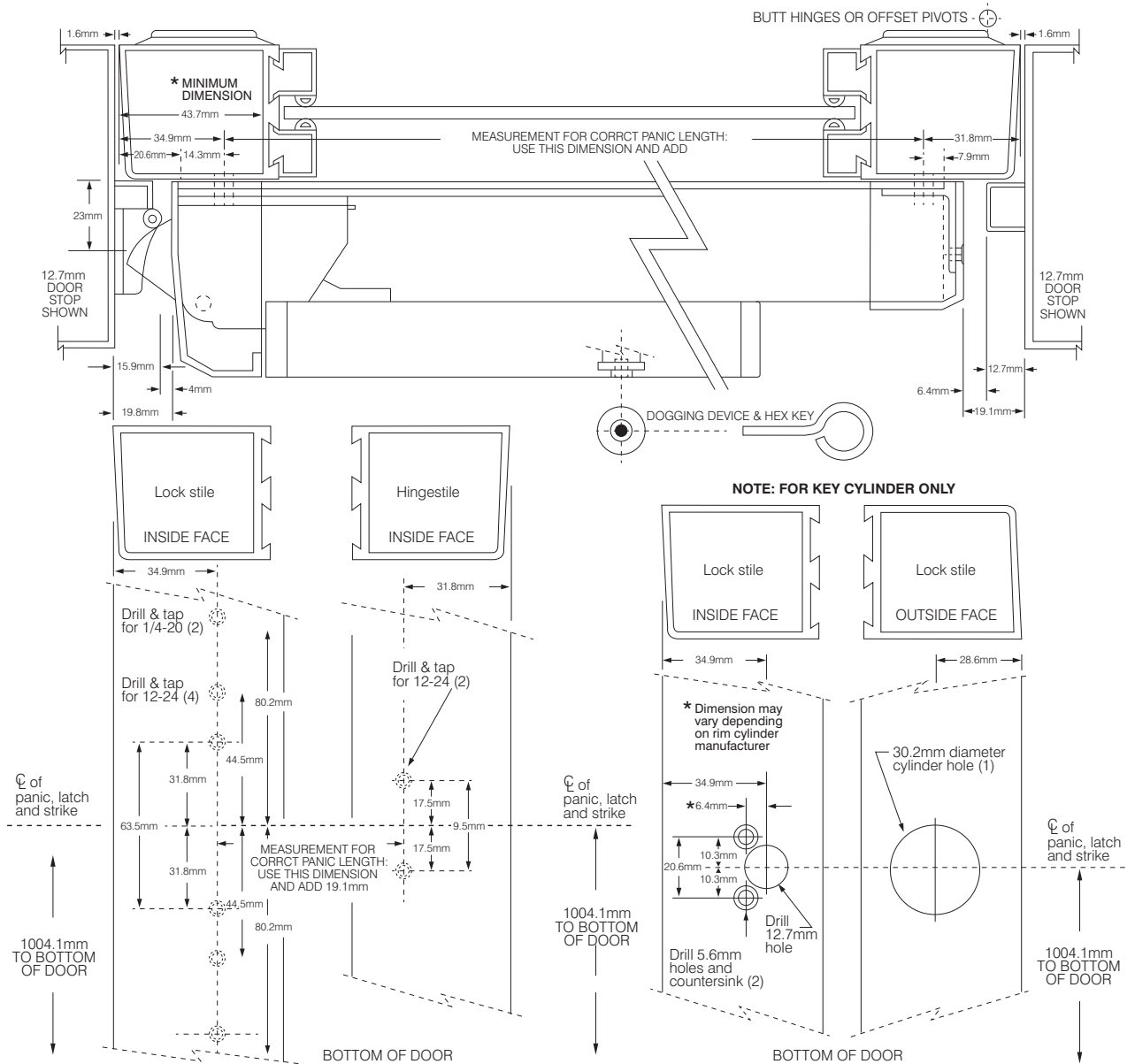

The Parkside Group Ltd

The Willow Centre
17 Willow Lane, Mitcham, Surrey, CR4 4NX
Tel: 020-8685 9685 Fax: 020-8646 5096
Email: axim@parksidegroup.co.uk
Web Site: www.axim.co.uk

SCALE	NTS @A4
DATE	MARCH 2014

For scaled technical or CAD drawings, please contact AXIM.

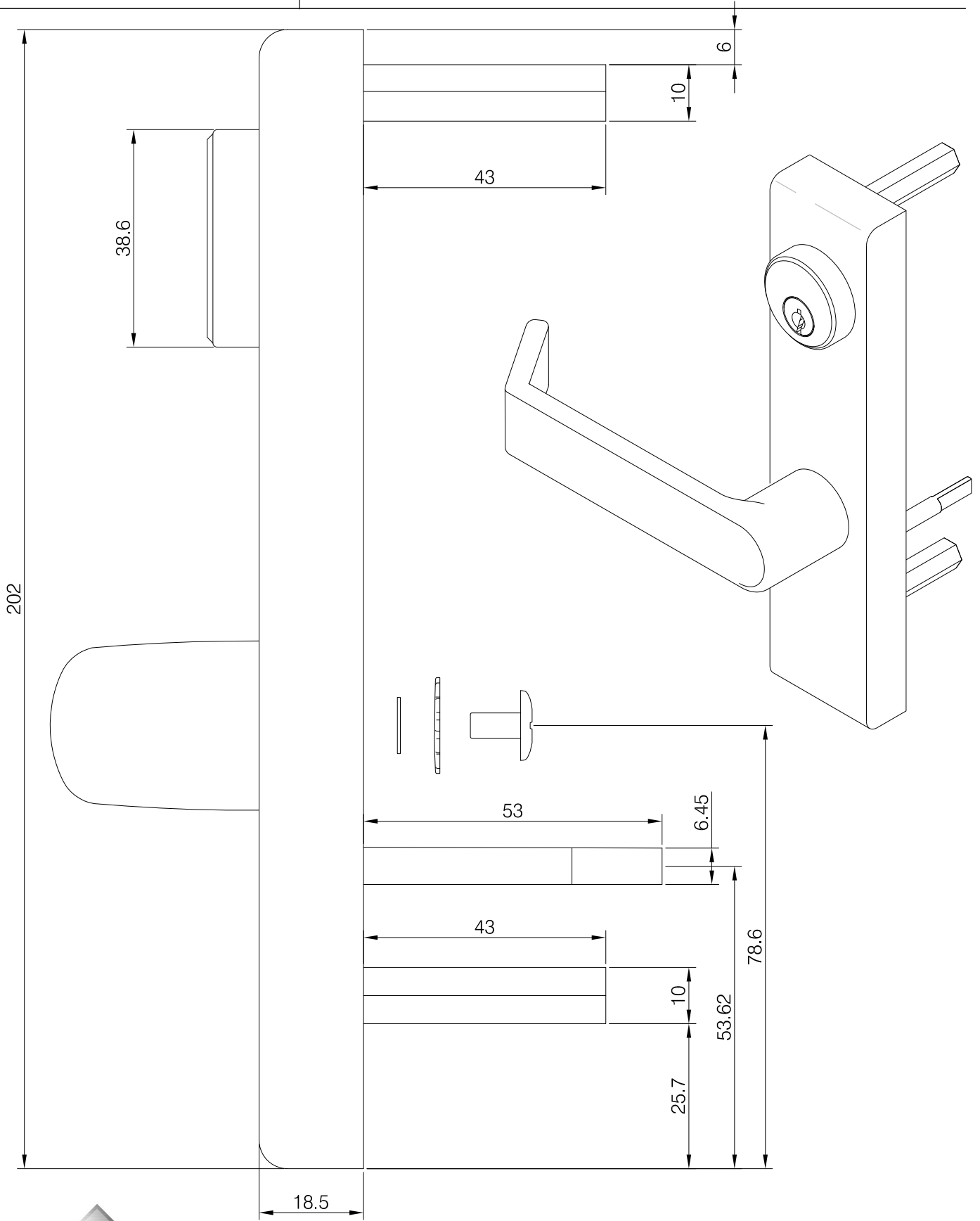

The Parkside Group Ltd

The Willow Centre
17 Willow Lane, Mitcham, Surrey, CR4 4NX
Tel: 020-8685 9685 Fax: 020-8646 5096
Email: axim@parksidegroup.co.uk
Web Site: www.axim.co.uk

SCALE	NTS @A4
DATE	SEPTEMBER 2023
For scaled technical or CAD drawings, please contact AXIM.	

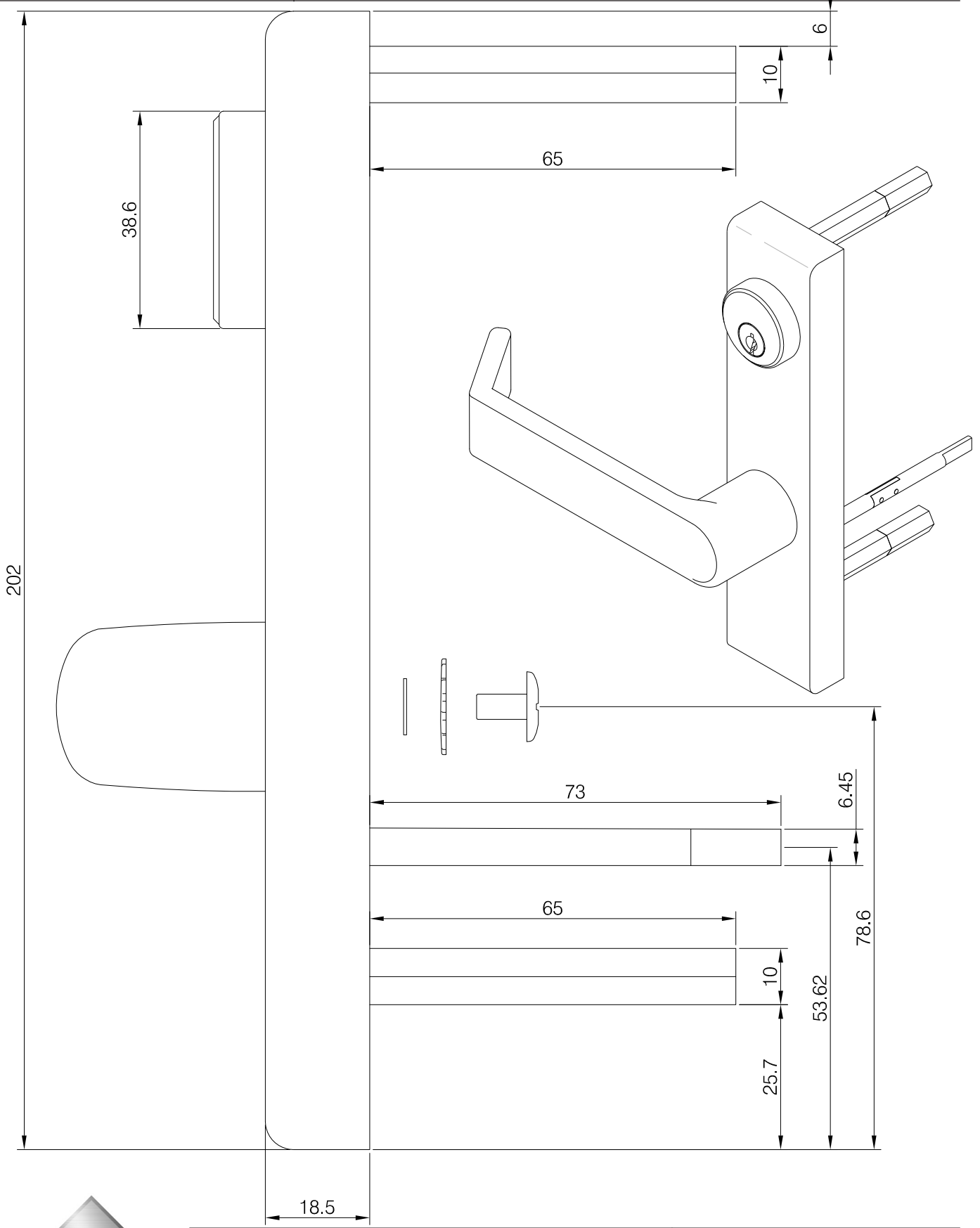

The Parkside Group Ltd
 The Willow Centre
 17 Willow Lane, Mitcham, Surrey, CR4 4NX
 Tel: 020-8685 9685 Fax: 020-8646 5096
 Email: axim@parksidegroup.co.uk
 Web Site: www.axim.co.uk

SCALE	NTS @A4
DATE	SEPTEMBER 2023
For scaled technical or CAD drawings, please contact AXIM.	