

UNIVERSAL APPLICATION

Left hand, right hand, single and double action doors.
Closing force 28 Nm for doors 120kg and up to 1150mm wide.
No hold and 90° hold open options.
105° hold open are available at request.

FULLY HYDRAULIC CONTROL

Provided by two valve screws
Back check range 85°-130°
Closing Range 130°-15°
Latching Range 15°-0°

BACKCHECK ZONE

Prevents damage to outward opening doors or where door swing is limited to 90°.

FULLY ADJUSTABLE

The 8500 series floor spring is positionally adjustable for height 4mm, width 10mm and length 6mm.

SIZE SELECTION CHART

DOOR WIDTH in mm	SPRING STRENGTH	CLOSING FORCE in Nm (Kpm)	NO HOLD OPEN	HOLD OPEN 90°
			PRODUCT CODE	
Up to 1150	Medium	25 (2.5)	8502-00	8502-90
Up to 800	Light	16 (1.6)	-	8501-90

Select medium spring for standard doors up to 1150mm wide up to 120kg.
Light spring for light or narrow internal doors.

ADJUSTMENT

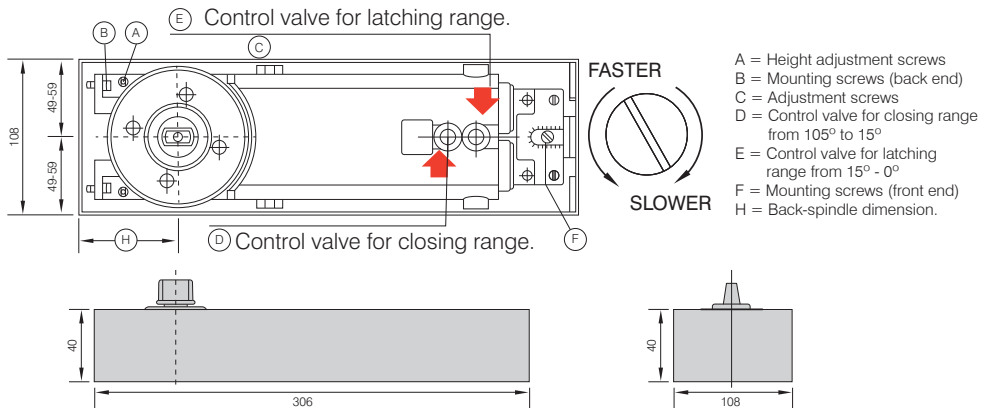

CLOSING RANGE

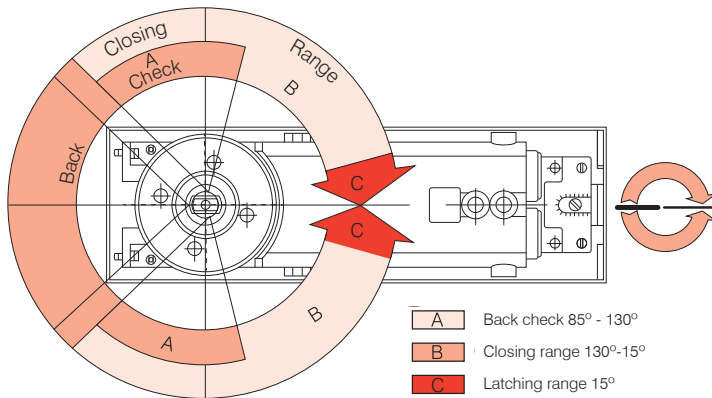

Left-hand door

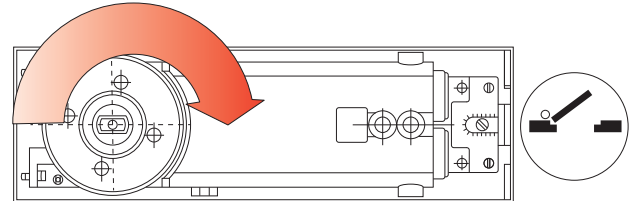

Right-hand door

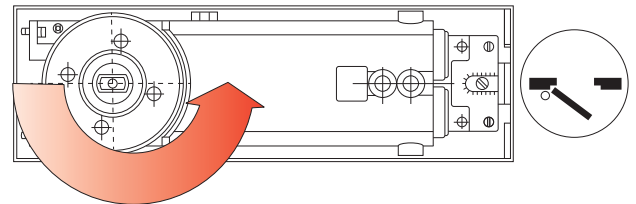

GUARANTEE

AXIM FLOOR SPRINGS ARE GUARANTEED FOR 30 MONTHS FROM THE DATE OF MANUFACTURE AGAINST DEFECT IN MATERIAL AND WORKMANSHIP. THIS GUARANTEE IS VOID IF THE PRODUCT HAS BEEN INCORRECTLY INSTALLED OR DAMAGED IN USE. CLAIMS FOR DAMAGE INCURRED OR WORK DONE THEREON WILL NOT BE ACCEPTED. AXIM RESERVE THE RIGHT TO UPDATE ITS PRODUCT SPECIFICATIONS WITHOUT PRIOR NOTICE.



The Parkside Group Ltd

The Willow Centre
17 Willow Lane, Mitcham, Surrey, CR4 4NX
Tel: 020-8685 9685 Fax: 020-8646 5096
Email: axim@parksidegroup.co.uk
Web Site: www.axim.co.uk

SCALE	NTS @A4
DATE	FEBRUARY 2023
For scaled technical or CAD drawings, please contact AXIM.	