

**UNIVERSAL APPLICATION**

Left hand, right hand, single and double action doors.  
Closing force 28 Nm for doors 150kg and up to 1200mm wide.  
No hold and 90° hold open options.

**FULLY HYDRAULIC CONTROL**

Provided by two valve screws  
Back check range 180°-70°   
Closing Range 70°-15°   
Latching Range 15°-0°

**BACKCHECK ZONE**

Prevents damage to outward opening doors or where door swing is limited to 90°.

**ADJUSTMENT**

With zinc plated cement box length 6mm, width 6mm, height 4mm.

**SPINDLE INSERT EXTENSIONS**

Up to 50mm, suitable for all types of doors.

**SPECIAL ORDER OPTIONS**

Hold open 85°, 105° and 120°.  
Light spring 15 Nm (for narrow width and light doors).

**SIZE SELECTION CHART**

DOOR WIDTH in mm	SPRING STRENGTH	CLOSING FORCE in Nm (Kpm)	NO HOLD OPEN	HOLD OPEN 90°
			PRODUCT CODE	
800 to 1200	Medium	28 (2.8)	6002-00	6002-90
Up to 800	Light	15 (1.5)	6001-00	6002-90

Select medium spring for standard doors up to 1200mm wide up to 150kg.  
Light spring for light or narrow internal doors.

**ADJUSTMENT**

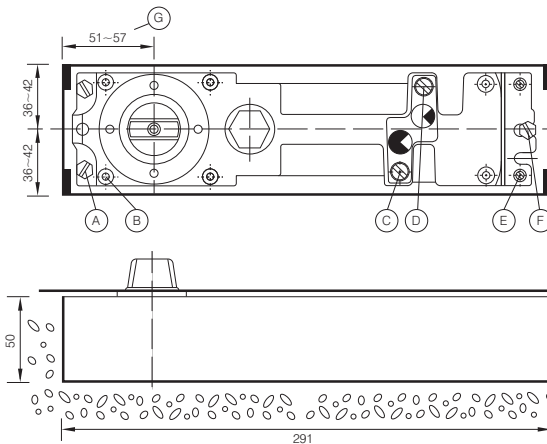

- A = Mounting screws (back end)
- B = Height adjustment screws (back end)
- C = Regulating valve for closing speed from 180° to 70°
- D = Regulating valve for closing speed from 70° to 0°
- E = Height adjustment screws (front end)
- F = Mounting screws (front end)
- G = Back-spindle dimension.

**CLOSING RANGE**

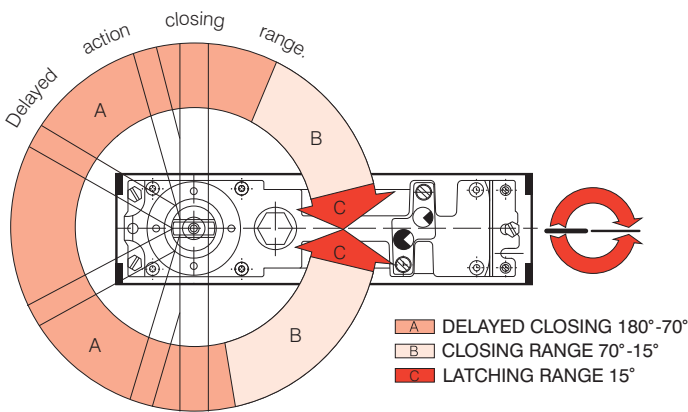

**Left-hand door**

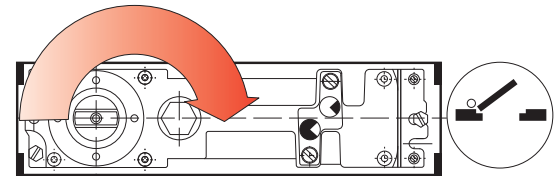

**Right-hand door**

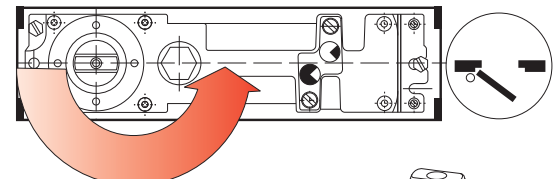

**FULL HYDRAULIC CONTROL**

Provided by three valve screws.

**COVER PLATES**

Universal for left hand, right hand single and double action doors. Three finishes available, stainless steel, Polished brass and B.M.A. (bronze).

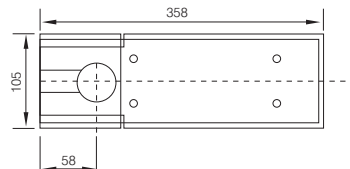

**SPINDLE INSERT EXTENSIONS**

Up to 50mm suitable for all types of doors.

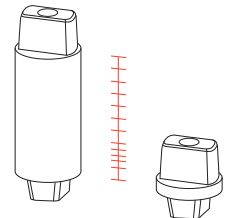

**GUARANTEE**

AXIM FLOOR SPRINGS ARE GUARANTEED FOR 30 MONTHS FROM THE DATE OF MANUFACTURE AGAINST DEFECT IN MATERIAL AND WORKMANSHIP. THIS GUARANTEE IS VOID IF THE PRODUCT HAS BEEN INCORRECTLY INSTALLED OR DAMAGED IN USE. CLAIMS FOR DAMAGE INCURRED OR WORK DONE THEREON WILL NOT BE ACCEPTED. AXIM RESERVE THE RIGHT TO UPDATE ITS PRODUCT SPECIFICATIONS WITHOUT PRIOR NOTICE.



**The Parkside Group Ltd**

The Willow Centre  
17 Willow Lane, Mitcham, Surrey, CR4 4NX  
Tel: 020-8685 9685 Fax: 020-8646 5096  
Email: axim@parksidegroup.co.uk  
Web Site: www.axim.co.uk

SCALE	NTS @A4
DATE	MARCH 2014
For scaled technical or CAD drawings, please contact AXIM.	