

**SURFACE MOUNTED HYDRAULIC
DOOR CLOSER**

The FC-15 is a multi-strength surface mounted hydraulic door closer, designed to complement the FC-10. A hardened rack and pinion mechanism is housed in a die cast aluminium body.

Suitable for left or right hand opening doors, top jamb and standard fixing. A parallel bracket is supplied for parallel arm installations.

Fixings for both metal and timber doors are included.

Adjustment valve screws and fixings are concealed behind a slide on, anodised dress plate. Each unit is complete with a full size template and easy to follow instructions.

ADJUSTMENT

Backcheck is a standard feature which protects doors in severe conditions.

The cushioning effect has been set for average conditions but can be increased or decreased by turning (valve screw D) clockwise or counterclockwise.

Closing speed is adjustable from 180-15° by turning (valve screw B) counterclockwise for faster or clockwise for slower

The latching (valve screw C) can be adjusted in the same way for the last 15° of closing.

DELAYED ACTION

Delayed action is available as an option giving a timed hold open from 180-70° allowing unhindered access, particularly useful on hospital doors. The speed is also adjustable using (valve screw E) in the same way as the closing and latching valves. Spring power is adjustable giving sizes 2-5 by tuning (screw F) with the 5mm hexagon wrench provided. See adjustment chart.

TEST VERIFICATION OF CONFORMITY

AXIM 1500 series closers have been included in successful tests to EN 1154: 1996.

AVAILABLE IN THREE FINISHES

- Silver.
- Dark bronze.
- White.
- Other colours available on special request.

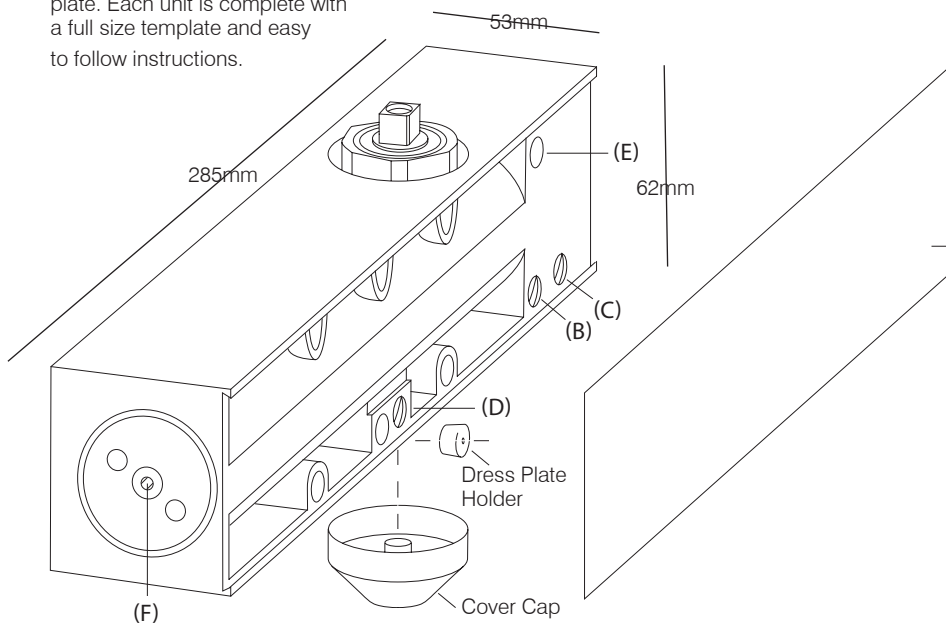

Dress Plate

(A) Regular Opening

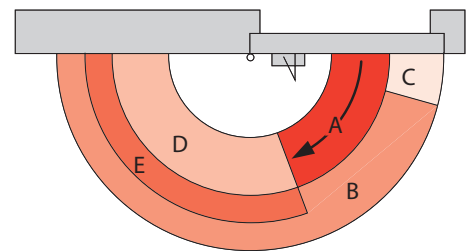

No. of turned	Power size	STANDARD/TOP JAMB INSTALLATION				Power size	PARALLEL INSTALLATION				Door weight (Kgs)
		Interior door width (mm)	Exterior door width (mm)		Closing force (Kgf.m)		Interior door width (mm)	Exterior door width (mm)		Closing force (Kgf.m)	
			Swing out	Swing in		Interior door width (mm)	Swing out	Swing in			
-3	2	900	800	700	1.2	1	900	800	600	1.2	25-45
0	3	1050	900	800	1.9	2	1050	700	700	1.9	40-65
+4	4	1200	1050	900	2.9	3	1200	900	800	2.9	60-85
+8	5	1350	1200	1050	3.8	4	1350	1200	1050	3.8	80-60

*Factory preset

ACCESSORIES

Hold open arm (plunger type) adjustable for any degree of retention.

Flat top bracket for installation on door frame when direct fixing is not possible.

SPECIAL ORDER OPTIONS

Special purpose accessories are available to cover the most difficult of applications.

For special widths, a FC-1600 closer is available.

Please contact Technical Department for further information.

GUARANTEE

AXIM SURFACE MOUNTED CLOSERS AND ACCESSORIES ARE GUARANTEED FOR 30 MONTHS FROM THE DATE OF MANUFACTURE AGAINST DEFECT IN MATERIAL AND WORKMANSHIP. THIS GUARANTEE IS VOID IF THE PRODUCT HAS BEEN INCORRECTLY INSTALLED OR DAMAGED IN USE. CLAIMS FOR DAMAGE INCURRED OR WORK DONE THEREON WILL NOT BE ACCEPTED. AXIM RESERVE THE RIGHT TO UPDATE ITS PRODUCT SPECIFICATIONS WITHOUT PRIOR NOTICE.



The Parkside Group Ltd

The Willow Centre
17 Willow Lane, Mitcham, Surrey, CR4 4NX
Tel: 020-8685 9685 Fax: 020-8646 5096
Email: axim@parksidegroup.co.uk
Web Site: www.axim.co.uk

SCALE	NTS @A4
DATE	FEBRUARY 2023
For scaled technical or CAD drawings, please contact AXIM.	