

The Parkside Group Ltd

The Willow Centre  
17 Willow Lane, Mitcham, Surrey, CR4 4NX  
Tel: 020-8685 9685 Fax: 020-8646 5096  
Email: axim@parksidegroup.co.uk  
Web Site: www.axim.co.uk

SCALE NTS @A4

DATE JULY 2017

For scaled technical or CAD drawings,  
please contact AXIM.

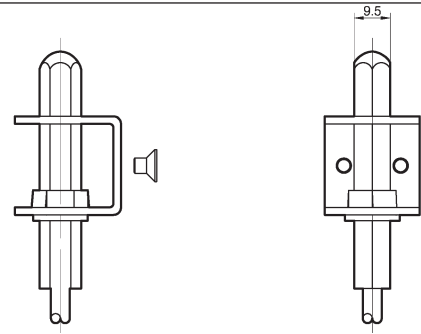
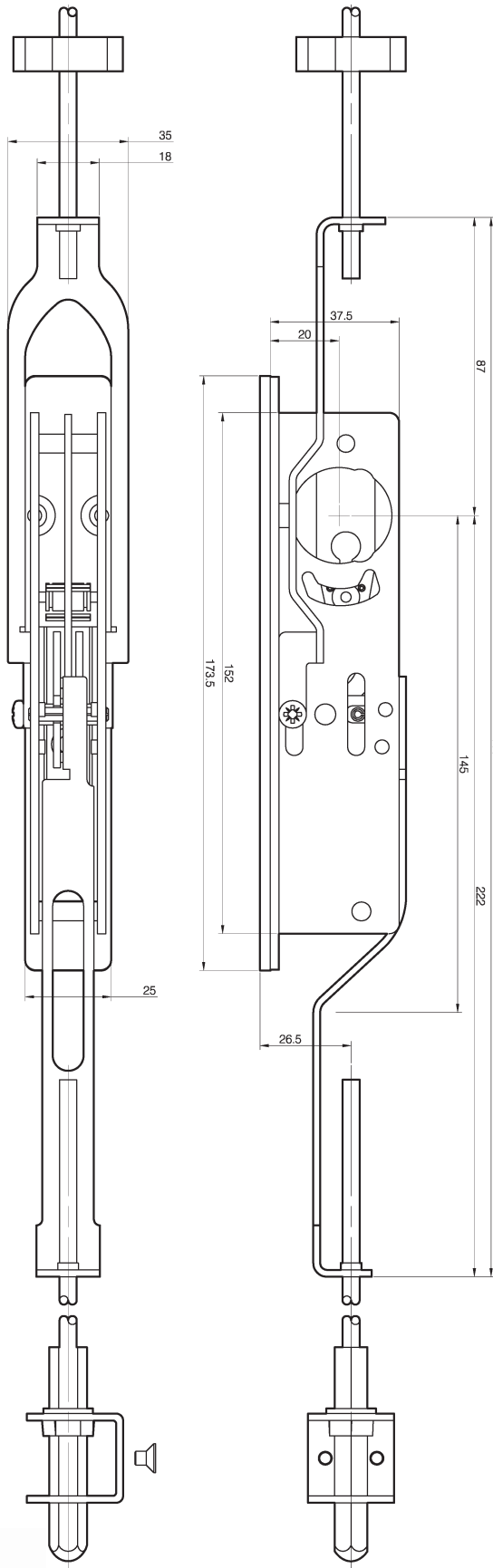

Top Bolt & Upper Bolt Guide

**Installation Notes:**

Install upper arm over lock side plates  
lower through the stile  
with bolt extended.

Install lower arm  
with bolt retracted.

Rod length cut to suite cylinder height  
to be approx 180mm less than overall cylinder  
height

**Specifications:**

Threshold & Top Bolt:  
Stainless steel Hexagonal 9.5mm flat to flat  
Bolt Throw = 17.5mm

PRODUCT CODES		
FINISH	FLAT	RADIUS
MILL	FB-6501-F25	FB-6501-R25

**Accessories**

**Round Cylinder**

- LK-2100-70** - (Keyed to differ in singles) 46mm DOOR STILE
- LK-2100-71** - (Keyed to differ in pairs) 46mm DOOR STILE
- LK-2100-71-S** - (Keyed alike in Singles) 46mm DOOR STILE
- LK-2100-71-SP** - (Keyed alike in pairs) 46mm DOOR STILE
- LK-2100-73** - Dummy - 46mm DOOR STILE
- LK-2100-75** - Dummy - 67mm DOOR STILE



The Parkside Group Ltd

The Willow Centre  
17 Willow Lane, Mitcham, Surrey, CR4 4NX  
Tel: 020-8685 9685 Fax: 020-8646 5096  
Email: axim@parksidegroup.co.uk  
Web Site: www.axim.co.uk

SCALE	NTS @A4
DATE	JULY 2017

For scaled technical or CAD drawings,  
please contact AXIM.