

The Axim ES-2200 series of electric strikes are an ANSI style door release, complete with stainless-steel short or long faceplates for use in metal or timber door frame applications. The electric release is designed to work with most leading brand deadlocking night latch locks. The ES-2200 also has two forms of monitoring available: latch (ES-2200-M) or latch with dual monitoring, open or closed (ES-2200-DM).

The Axim ES-2200 series are shipped as fail secure and can be converted to fail safe mode by the simple removal of a screw. The Axim ES-2200 can also be set to 12V or 24V by simply reconfiguring the wires in a different sequence.

Technical Specification:

Application

Fail - Safe or Fail Secure

Note: DC Power supply required for Fail Safe Operation.

Maximum Holding Force

450kgs

Case Detail:

86mm x 32.8mm x 40mm

Zinc Aluminium Alloy Material

Faceplates:

124mm x 31.7mm - Flat Design, Stainless Steel material,

201.5mm x 31.7mm - Flat Design, Stainless Steel material,

Finish: Brushed / Stainless Steel.

Mechanism Design:

Stainless Steel Internal Blocking Mechanism.

Strike Aperture Detail:

44.7mm (Length) x 19mm (Width) x 13.3mm (Depth)

Stainless Steel retaining jaw.

Suitable Door Gap:

Min. 3mm (1/8") Operational 3-5mm

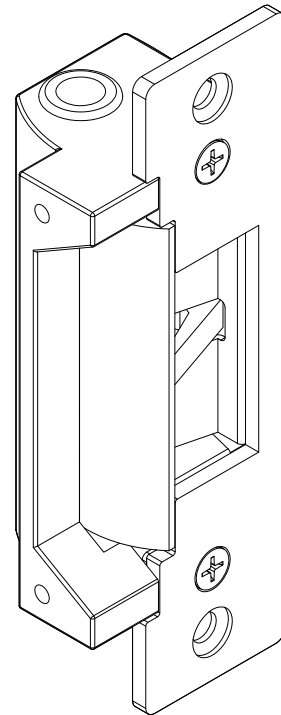

Testing:

ANSI / BHMA 156.5 Grade 1

CE Marked - Electrical

Product Options and Accessories

ES-2200-S

ES-2200-M (Monitored)

ES-2200-DM (Dual Monitored)

ES-2200-EL10 Extension Lip (10mm)

ES-2200-EL25 Extension Lip (25mm)

ES-2200-EL50 Extension Lip (50mm)



The Parkside Group Ltd

The Willow Centre
17 Willow Lane, Mitcham, Surrey, CR4 4NX
Tel: 020-8685 9685 Fax: 020-8646 5096
Email: axim@parksidegroup.co.uk
Web Site: www.axim.co.uk

SCALE	NTS @A4
DATE	NOVEMBER 2019
For scaled technical or CAD drawings, please contact AXIM.	

Dimensions:

Short Faceplate

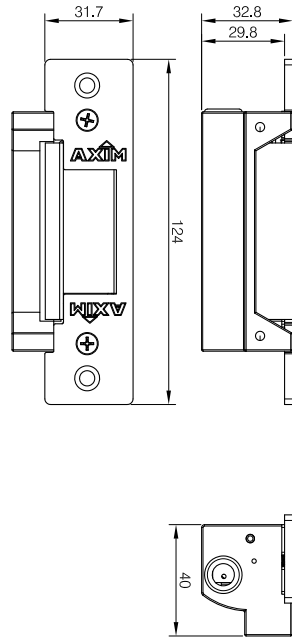

Long Faceplate

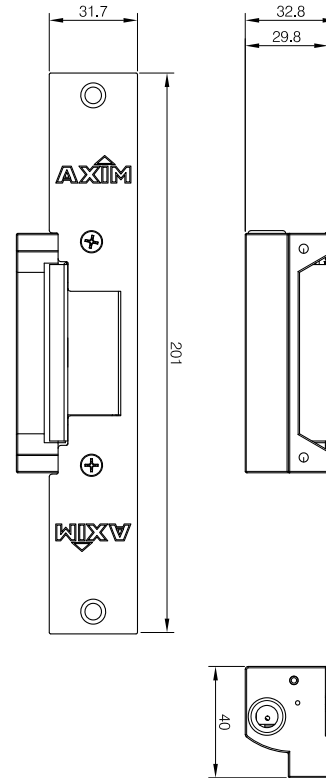

Wiring Instructions:

Voltage:

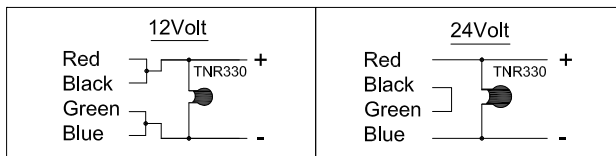

Sensor:

<p>Lock Sensor:</p> <p>Purple Com Brown NC Yellow NO</p>	<p>Door Sensor:</p> <p>Orange Com White NC Grey NO</p>
---	---

Sensor contact rating: 1A Max, 30V AC/DC

**MOV provided with the package, to be used for surge protection between + and - Power terminals.

The strike can be used in either fail safe or fail secure mode. Ensure that the screw is positioned in either hole as per illustration, and either function can be achieved.

Changing from Fail-Secure to Fail Safe Mode:

Default setting is for fail-secure mode.

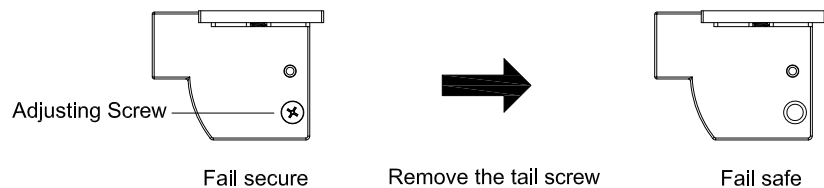

The Parkside Group Ltd

The Willow Centre
17 Willow Lane, Mitcham, Surrey, CR4 4NX
Tel: 020-8685 9685 Fax: 020-8646 5096
Email: axim@parksidegroup.co.uk
Web Site: www.axim.co.uk

SCALE	NTS @A4
DATE	NOVEMBER 2019
For scaled technical or CAD drawings, please contact AXIM.	

General Installation Instructions:

1. Check with a suitable meter if the regulated power supply or controller being used to operate the strike can provide the required voltage within a +/- 10% tolerance, and that the voltage can be stable during operation under all circumstances.

Warning: Damages caused by connection of an incorrect voltage are not covered by the product warranty.

2. Make a mounting hole on the door frame using the body of the strike as the template to make a proper cutout. Ensure that if the mortise lock being used has a deadlocking snib or trigger, the location of the strike must not allow the snib to enter the 'keep' area.

3. Position the strike and drill the two fixing holes.

4. Ensure that all wiring is correctly terminated and not snagged within the mortise. Install the strike temporarily in this correct position and check that there is no mechanical interference between the door, the lock faceplate and the strike face and extension lip (if fitted) during the closing cycle.

5. Check that no side load pressure is exerted on the strike when the door is closed.

6. Secure the strike and re-check operation.

