

The logo for AXIM Architectural Hardware features the word "AXIM" in a large, bold, metallic font with a 3D effect. A red triangle is positioned above the letter "I". Below "AXIM", the words "ARCHITECTURAL HARDWARE" are written in a smaller, black, sans-serif font.

AXIM
ARCHITECTURAL HARDWARE

FC1500
Multi Strength Surface Mounted Closer



maximise without compromise



FC1500 Multi Strength Surface Mounted Closer

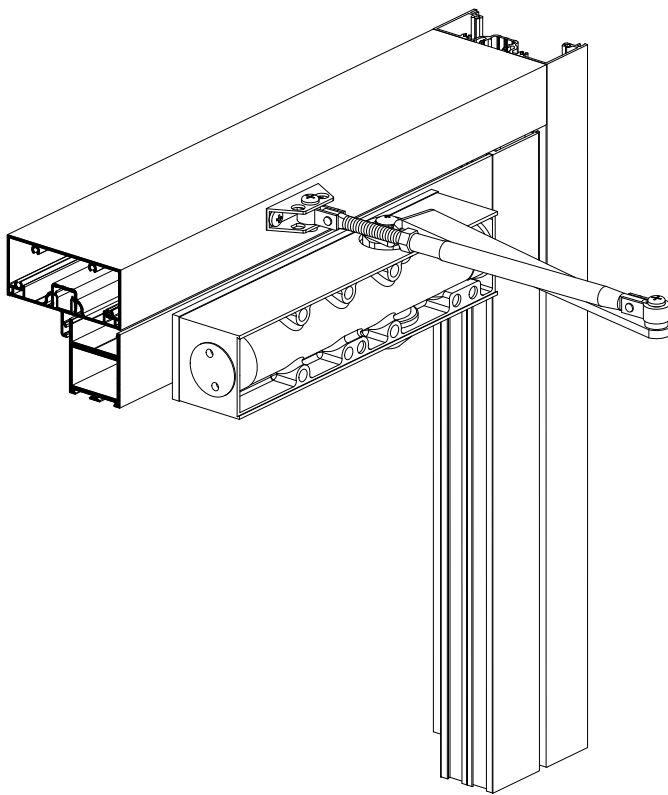

The FC-1500 is a multi-strength surface mounted hydraulic door closer, designed to complement the FC-1000. A hardened rack and pinion mechanism is housed in a die cast aluminium body.

Suitable for left or right hand opening doors, top jamb and standard fixing. A parallel bracket is supplied for parallel arm installations.

Adjustment valve screws and fixings are concealed behind a slide on, anodised dress plate.

Features:

- Tested to EN1154
- FC1500 has all the functionality of the FC1000 but with added features
- Multi strength surface mounted closer
- Adjustable to accommodate a variety of door widths
- Backcheck can be adjusted to suit application
- Delayed action available as an option allowing unhindered access particularly useful for Hospitals

www.axim.co.uk

For further information about any of the goods and services provided by Axim, contact us at the address below.

Axim Architectural Hardware, The Willow Centre, 17 Willow Lane, Mitcham, Surrey, CR4 4NX. Tel: 0208 685 9685 • Fax: 0208 646 5096 • Email: axim@parksidigroup.co.uk

AXIM
ARCHITECTURAL HARDWARE

gai associate member

CIAB
Council for Aluminium
in Building
Member