

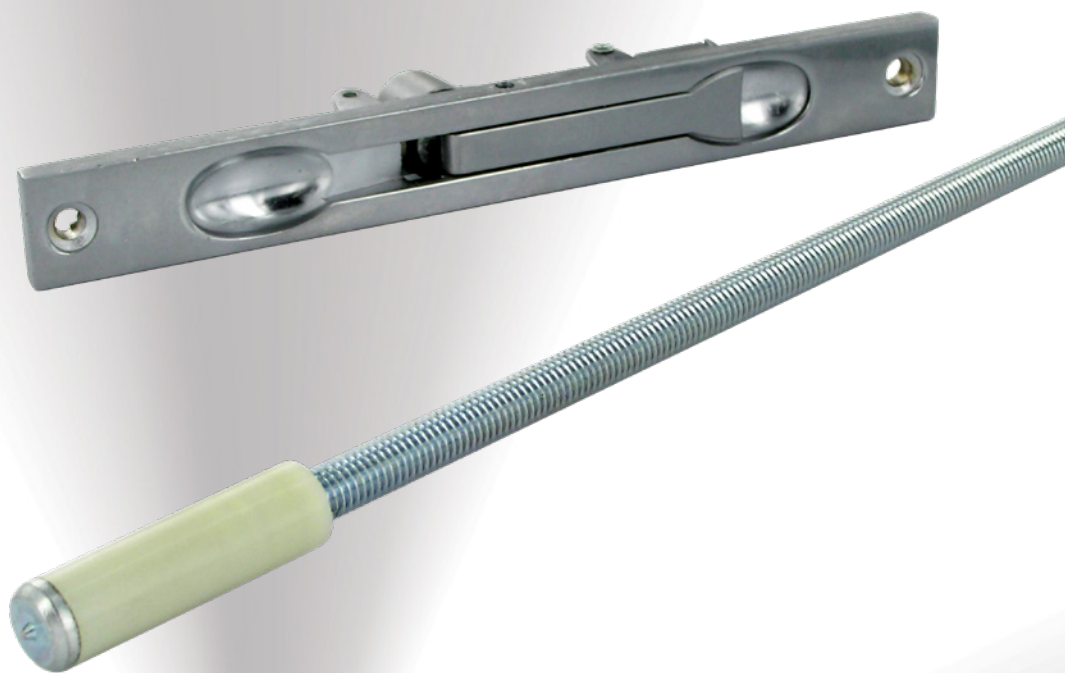

AXIM
ARCHITECTURAL HARDWARE

FB6300 Series
Flush Bolt



maximise without compromise



FB6300 Flush Bolt

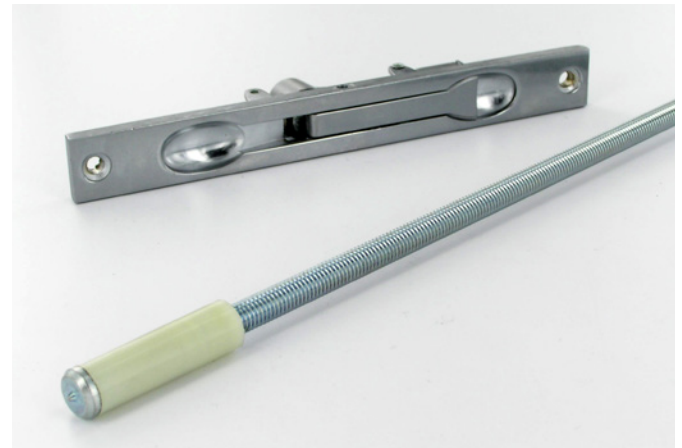
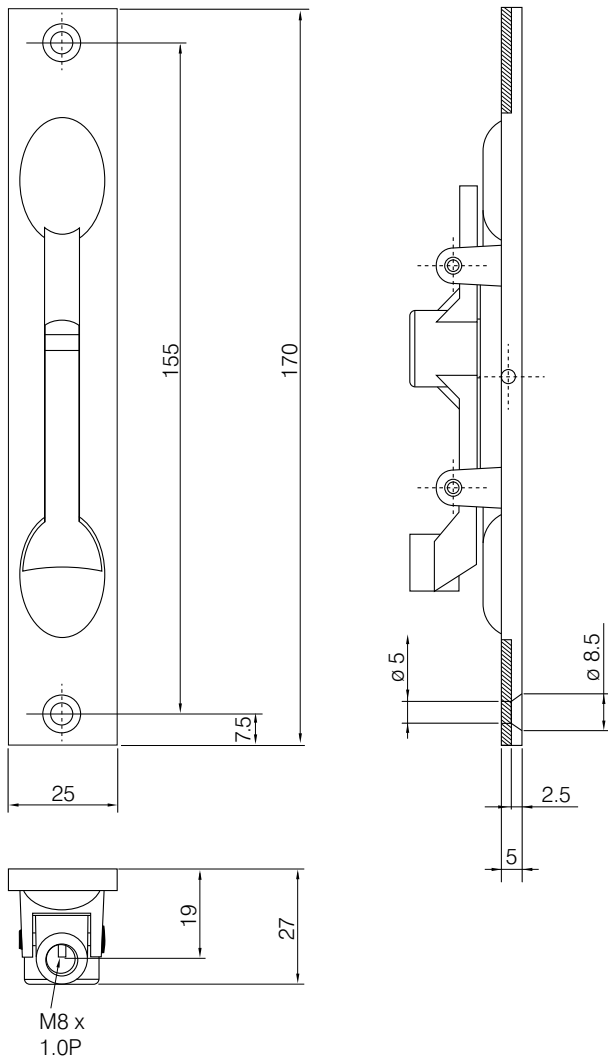

Flush door bolts are rebated into a door, and are normally operated by a small lever which sits perfectly flush both when the bolt is engaged and the doors closed. For maximum security Axim flush bolts have a hardened steel bolt, zinc plated with an anti-rattle sleeve and secure the slave leaf of a pair of doors. A standard installation requires two flushbolts morticed into the top and bottom of the door.

Axim's FB-63 extension flush bolts are a range of lever action flush bolts, primarily intended for mounting in the leading edge or inside face of the slave leaf of a pair of doors.

Features:

- The Axim FB6300 door bolts are guaranteed for 30 months
- Smooth lever action
- Available in 2 lengths, 305mm & 152mm to suit differing door heights
- Silver satin chrome, bronze powder coat or a mill finishes
- Shoot bolt: 18 mm diameter and a die cast zinc alloy body mechanism
- Floor socket keep is sprung loaded and dust resistant with a satin chrome finish

www.axim.co.uk

For further information about any of the goods and services provided by Axim, contact us at the address below.

Axim Architectural Hardware, The Willow Centre, 17 Willow Lane, Mitcham, Surrey, CR4 4NX. Tel: 0208 685 9685 • Fax: 0208 646 5096 • Email: axim@parksidegroup.co.uk

AXIM
ARCHITECTURAL HARDWARE

gai associate member

CIAB
Council for Aluminium
in Building
Member