

Panic exit device,
concealed vertical rod,
42" flat touch bar

Aluminium PR-7100-AL
Bronze PR-7100-DU
Black PR-7100-BK

Extension rod with coupler
(300mm extension) RE-712

Rim cylinder lock (supplied with 2 keys)
Aluminium RC-785-AL
Bronze RC-785-DU
Black RC-785-BK

Rim cylinder lock keyed alike
Aluminium RC-785-AL KA

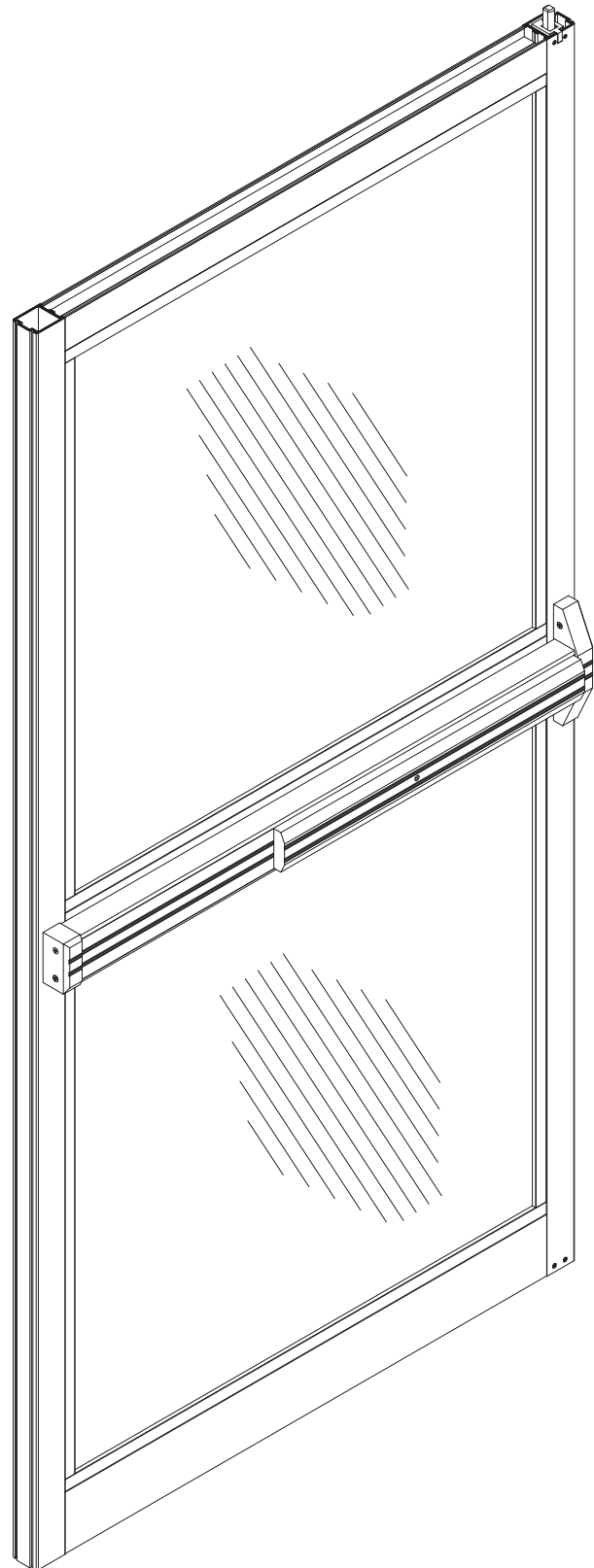

THE PARKSIDE GROUP LTD

THE WILLOW CENTRE
17 WILLOW LANE, MITCHAM, SURREY, CR4 4NX
Tel: 020-8685 9685 Fax: 020-8646 5096
Email: axim@parksidegroup.co.uk
Web Site: <http://www.axim.co.uk>

SCALE NTS @A4

DATE MARCH 2014

For scaled technical or CAD drawings,
please contact AXIM.

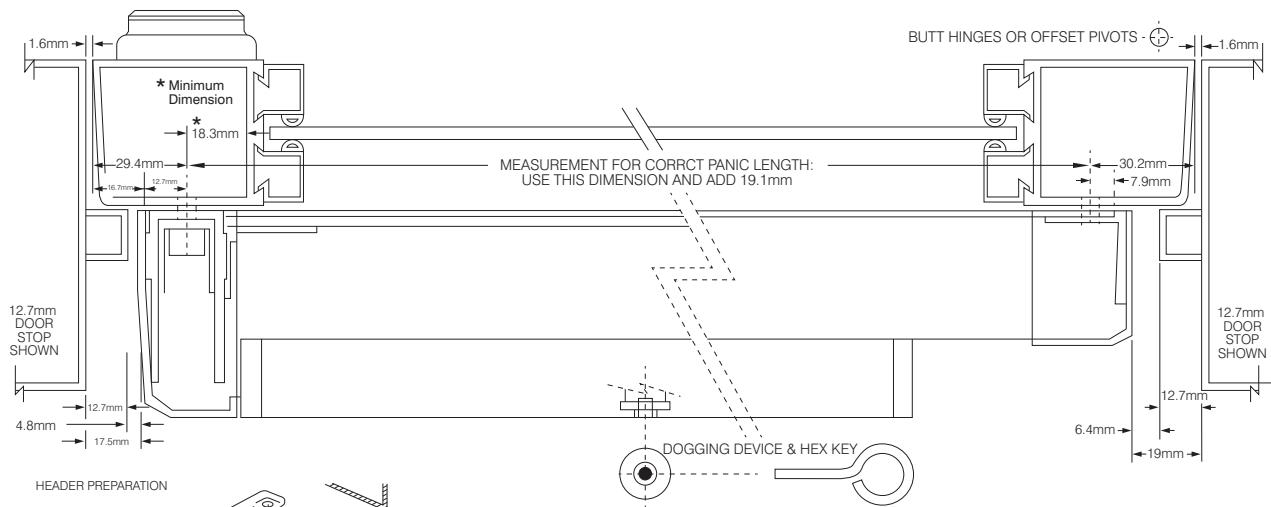

HEADER PREPARATION

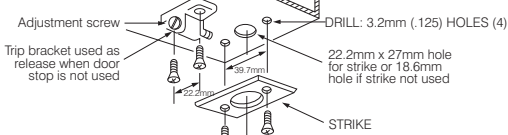

INSTALLATION INSTRUCTIONS

- Determine hand of door and prepare inside face of Lock and Hinge Stile as shown.
- NOTE: For Key Cylinder Only**
If key cylinder is to be used, prepare inside and outside face of Lock Stile as shown.
- Insert Concealed Vertical Rod into Lock Stile and secure Centre Case Assembly with (2) 1/4-20 Hex Mounting Studs (short end for standard doors and long end for monumental door).
- NOTE: For Key Cylinder Only**
If key cylinder is used, insert Cylinder in Mounting Pad and secure with Locking Ring. Remove Key, loosen (2) 1/4-20 Hex Mounting Studs, and secure Mounting pad with cylinder using (2) 8-32* 49.2mm Flat Head Machine Screws. Re-tighten Hex Mounting Studs.
- Adjust length of top and bottom Actuating Bolts by turning in or out. When the Push Bar is fully depressed and Dogged, the Actuating Bolts should be slightly recessed from flush with the top and bottom of the door. Install top and bottom Bolt Guide with (6)#10*12.7mm Flat head Self-Threading screws.
NOTE: Large Bevel of Actuating Bolts must be inside and outside of stile.
- Measure for correct Panic Length. Measure distance from centreline of mounting holes on Lock and stiles of door as indicated AND ADD 19.1mm. Mark the measurement on back of the Panic form Latch End towards the Hinge End to be cut. Stuff a rag in the end of the Back Channel prior to cutting off excess length so that metal chips will not get into the mechanism. Protect the area to be cut and then cut to correct length.
- Drill (2) clearance holes for 12-24 machine screws in Hinge End of Back Channel as indicated. Attach Hinge End of Panic and Hinge End Mounting Bracket **LOOSELY** on Hinge Stile with (2) 12-24*25.4mm Pan Head Thread Cutting Machine Screws and Lock Washers or (2) #12*31.8mm Pan Head All-Purpose Screws and Lock Washers.
- Position Latch End of Panic over Hex Mounting Studs, Secure Latch End of Panic with (2) 1/4-20 Hex Nuts and Lock Washers, Tighten the (2) screws on the Hinge End Mounting Bracket, put crank into Latch End Housing, making sure that Link fits over end pin, insert screw into crank and tighten.
- Attach Latch End Cover and Hinge End Cover with (4)8-32*12.7mm Flat Head Thread Cutting Machine Screws.
- Prepare Header and Threshold Strikes as shown. If Header and Threshold Strikes are required, install using (4)#8*9.5mm Flat Head Self-threading Screws or (4)#6*25.4mm Flat Head All-purpose Screws.

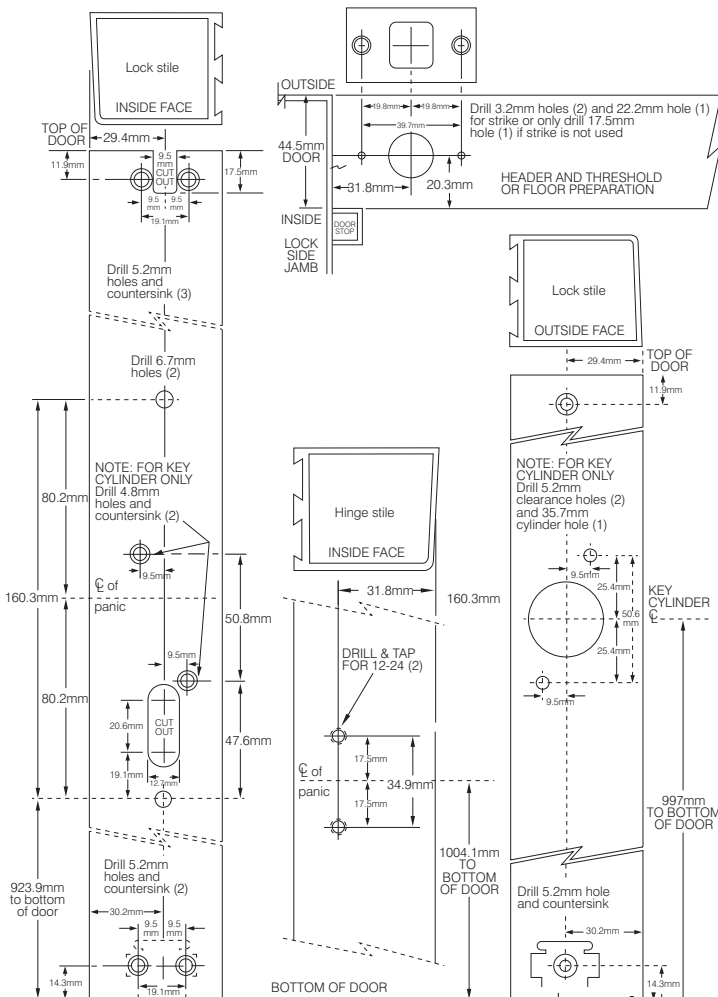

OPERATING INSTRUCTIONS

TO UNLOCK DOOR USING CYLINDER KEY:
Turn key approximately 1/4 turn **counterclockwise** and open the door, return key to centre and remove.

DOGGING USING CYLINDER KEY:
Open the door, fully depress Push Bar and hold, turn the key **clockwise** approximately 45°, return key to center and remove.

TO RELEASE CYLINDER KEY DOGGING:
Turn key **counterclockwise** approximately 45°, return key to centre and remove.

DOGGING USING DOGGING KEY:
Fully depress Push Bar and hold. Using Hex Dogging Key **push in** dogging device and turn **clockwise** approximately 1/2 turn.

TO RELEASE DOGGING KEY DOGGING:
Hold Touch Bar down. Using Hex Dogging Key **push in** Dogging Device and Turn **counterclockwise** approximately 1/2 turn. Dogging will be released.



THE PARKSIDE GROUP LTD
 THE WILLOW CENTRE
 17 WILLOW LANE, MITCHAM, SURREY, CR4 4NX
 Tel: 020-8685 9685 Fax: 020-8646 5096
 Email: axim@parksidegroup.co.uk
 Web Site: http://www.axim.co.uk

SCALE	NTS @A4
DATE	MARCH 2014
For scaled technical or CAD drawings, please contact AXIM.	

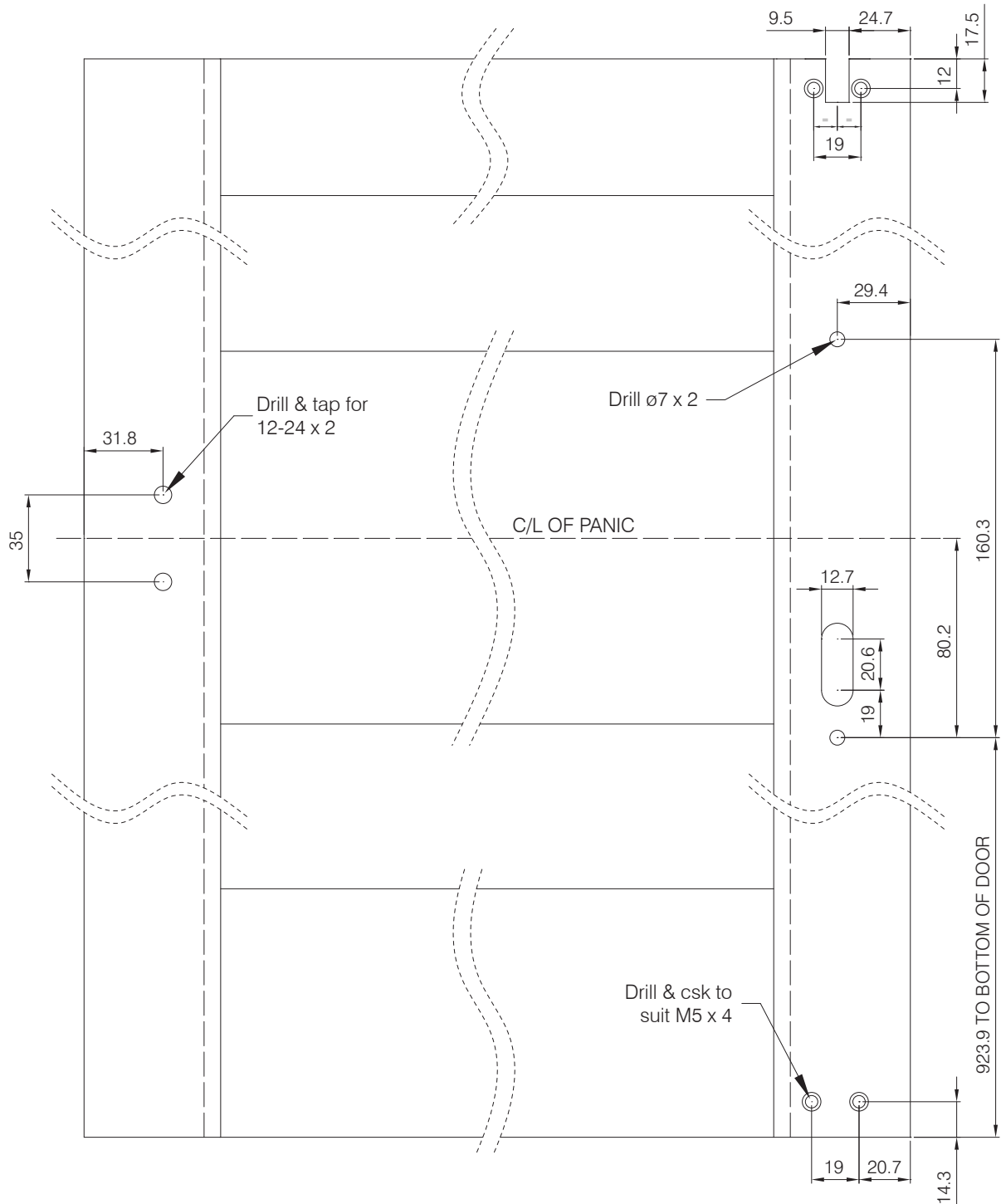
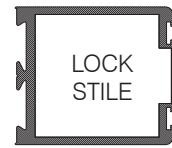
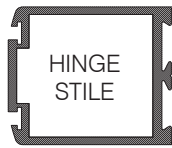

THE PARKSIDE GROUP LTD

THE WILLOW CENTRE
17 WILLOW LANE, MITCHAM, SURREY, CR4 4NX
Tel: 020-8685 9685 Fax: 020-8646 5096
Email: axim@parksidegroup.co.uk
Web Site: <http://www.axim.co.uk>

SCALE	NTS @A4
DATE	MARCH 2014
For scaled technical or CAD drawings, please contact AXIM.	

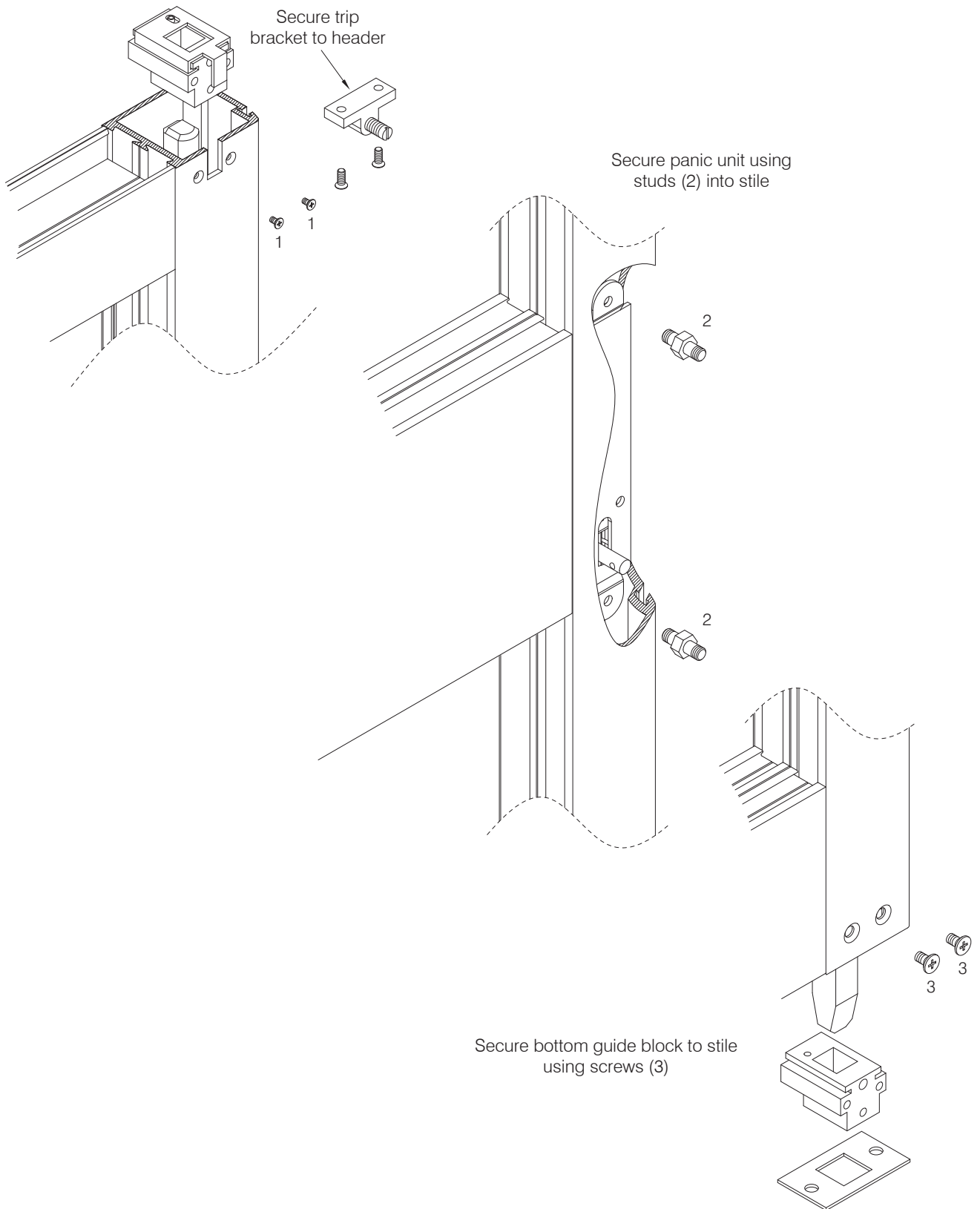

THE PARKSIDE GROUP LTD

THE WILLOW CENTRE
17 WILLOW LANE, MITCHAM, SURREY, CR4 4NX
Tel: 020-8685 9685 Fax: 020-8646 5096
Email: axim@parksidegroup.co.uk
Web Site: <http://www.axim.co.uk>

SCALE	NTS @A4
DATE	MARCH 2014
For scaled technical or CAD drawings, please contact AXIM.	

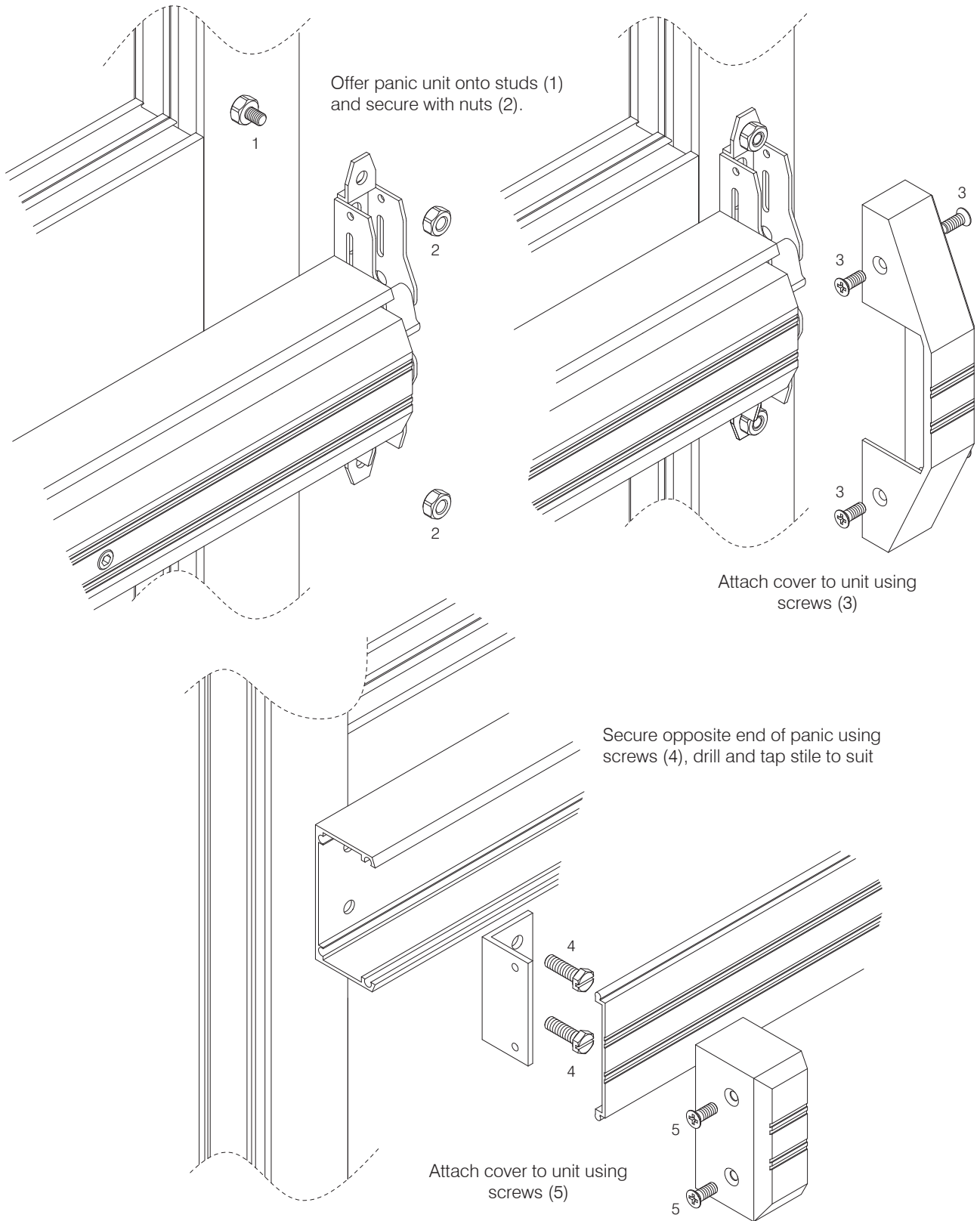

THE PARKSIDE GROUP LTD

THE WILLOW CENTRE
17 WILLOW LANE, MITCHAM, SURREY, CR4 4NX
Tel: 020-8685 9685 Fax: 020-8646 5096
Email: axim@parksidegroup.co.uk
Web Site: <http://www.axim.co.uk>

SCALE	NTS @A4
DATE	MARCH 2014
For scaled technical or CAD drawings, please contact AXIM.	

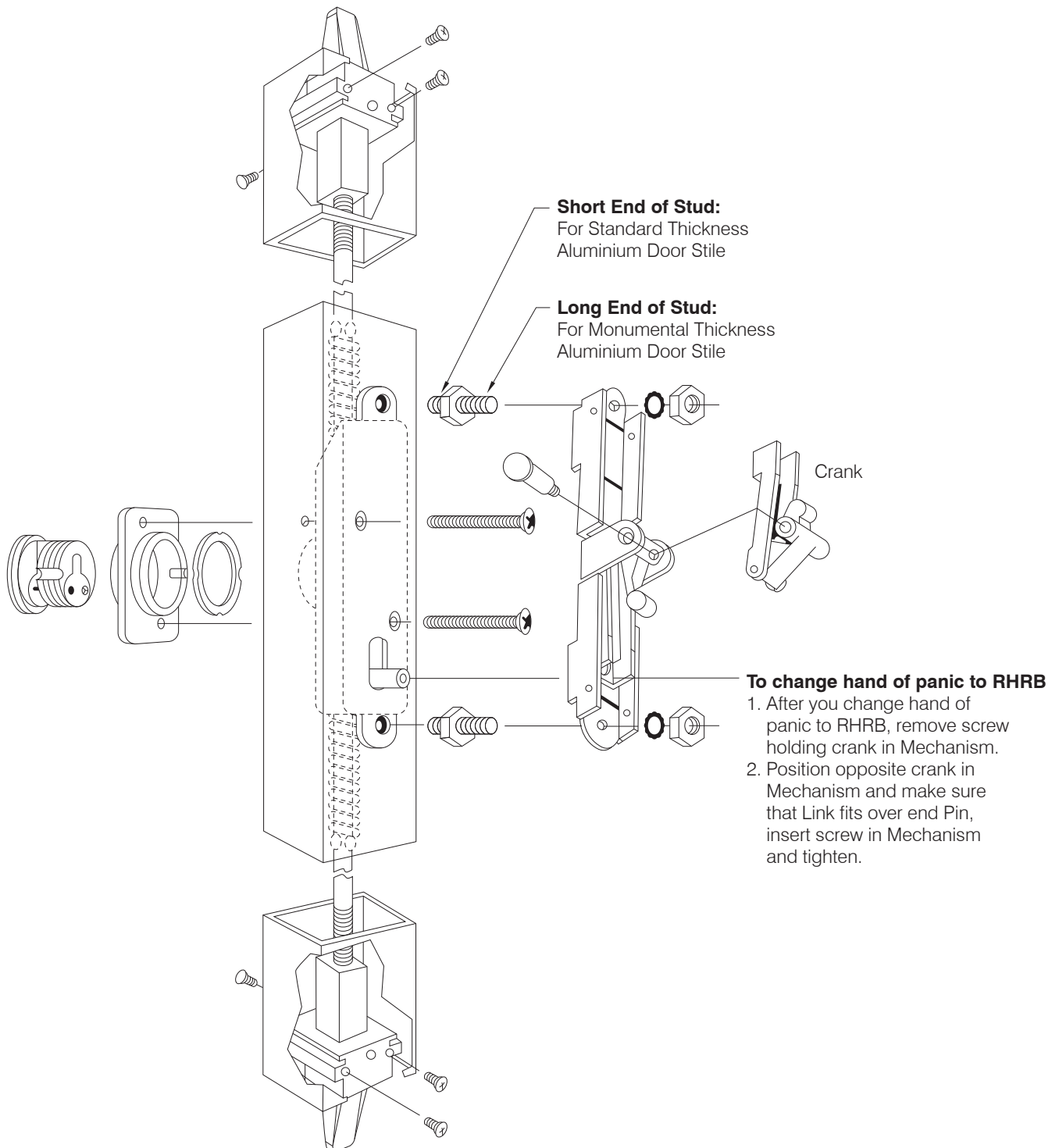

THE PARKSIDE GROUP LTD

THE WILLOW CENTRE
17 WILLOW LANE, MITCHAM, SURREY, CR4 4NX
Tel: 020-8685 9685 Fax: 020-8646 5096
Email: axim@parksidegroup.co.uk
Web Site: <http://www.axim.co.uk>

SCALE	NTS @A4
DATE	MARCH 2014
For scaled technical or CAD drawings, please contact AXIM.	

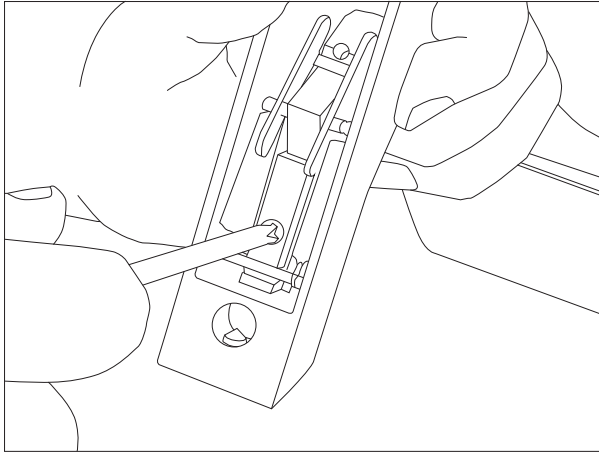

1) Remove securing screw in back of handle unit

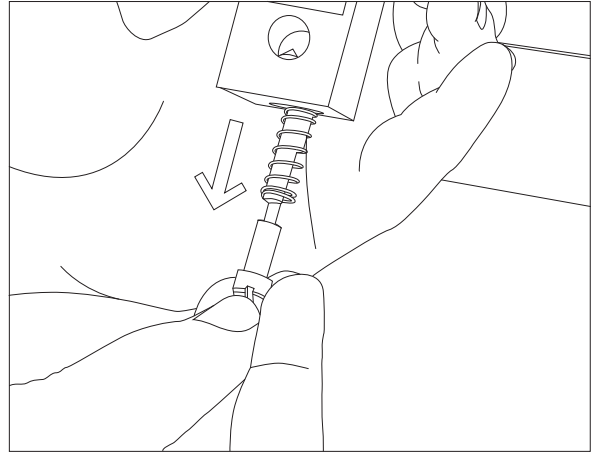

2) Once securing screw is removed existing pin should be ejected by internal spring

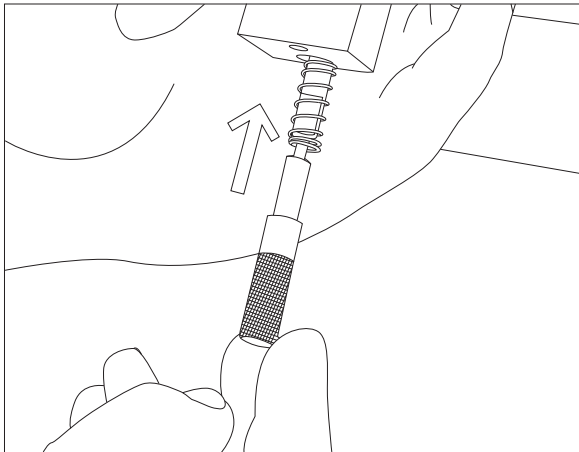

3) Replace existing pin with knurled pin (retaining original spring)

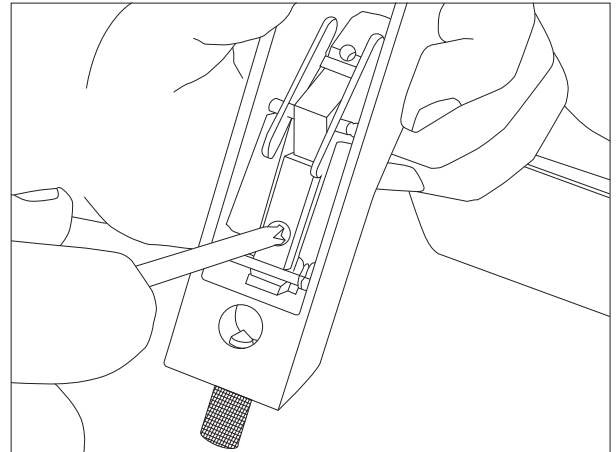

4) Replace securing screw holding knurled pin in far enough that notch on dogging pin can locate on securing screw

LH-725 Locking handle

Key Controlled Outside trim for use with PR7085, PR7085P, and PR7100 concealed rod Panic Devices.

Uses Axim screw in Mortice cylinder with MS type CAM.

Not handed. (Field reversible).

All Axim Panic Exit Hardware is supplied with comprehensive instructions and full size templates for ease of installation.

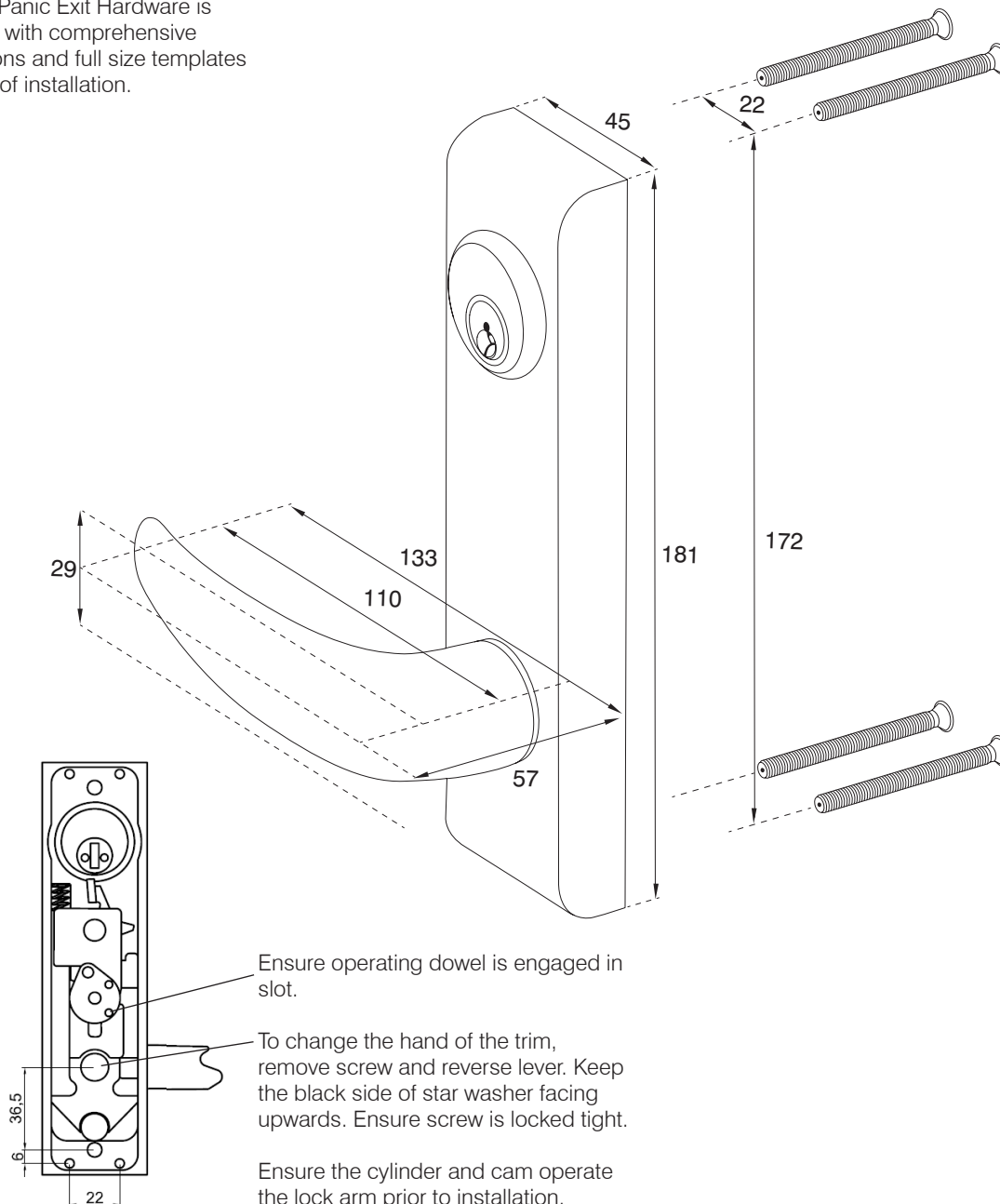

THE PARKSIDE GROUP LTD

THE WILLOW CENTRE
17 WILLOW LANE, MITCHAM, SURREY, CR4 4NX
Tel: 020-8685 9685 Fax: 020-8646 5096
Email: axim@parksidegroup.co.uk
Web Site: <http://www.axim.co.uk>

SCALE	NTS @A4
DATE	NOVEMBER 2016
For scaled technical or CAD drawings, please contact AXIM.	

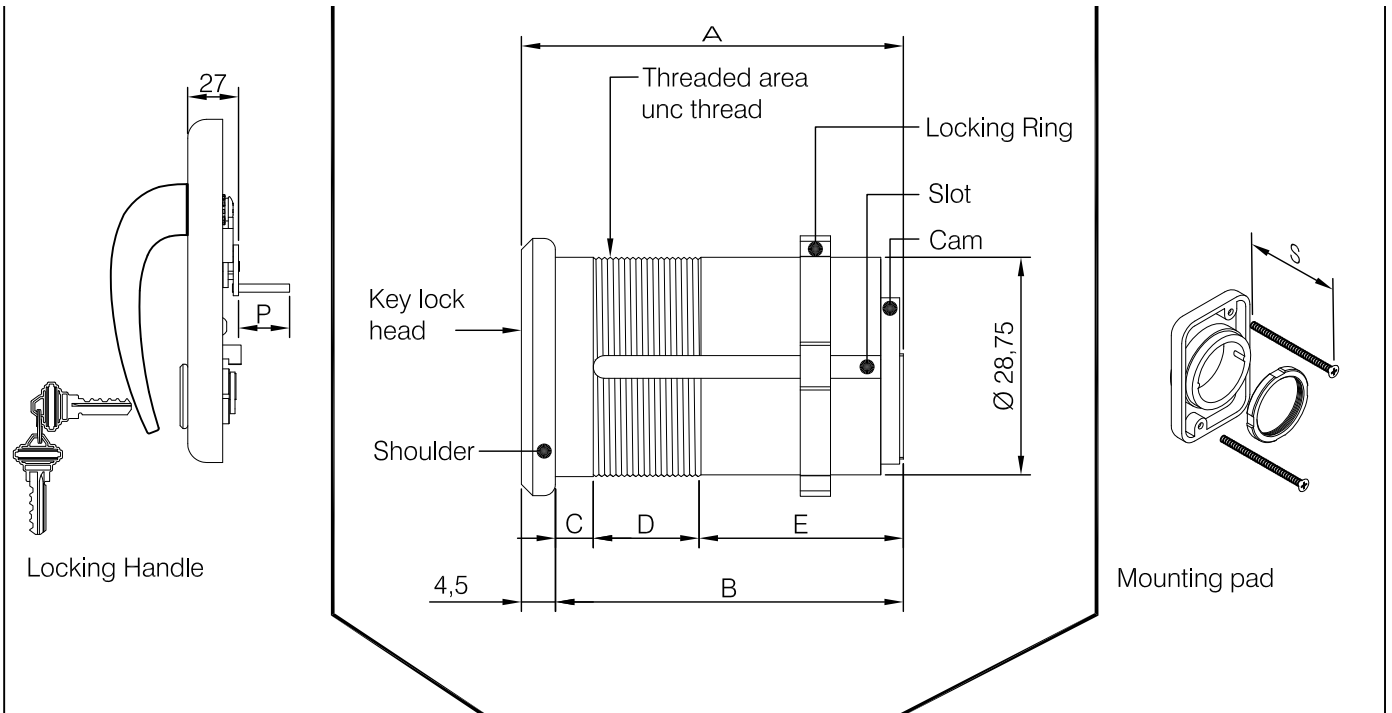

Locking Handle	Pin Length	Rim Cylinder table details		Mounting Pads	Screw Length
LH 725	P = 6 mm	RC - 785		MP786	S = 57 mm
		A = 29.5	46 mm Door tile		
		B = 25.0			
		C = 7.0			
		D = 12.0			
E = 6.0					
LH - 730	P = 9 mm	RC - 787		MP788	S = 65 mm
		A = 32.5	49 mm Door stile		
		B = 28.6			
		C = 5.0			
		D = 13.0			
E = 10.0					
LH - 740	P = 14 mm	RC - 789		MP790	S = 65 mm
		A = 37.5	54 mm Door stile		
		B = 33.6			
		C = 7.0			
		D = 21.0			
E = 5.0					
LH - 745	P = 27 mm	RC - 791		MP792	S = 90 mm
		A = 53.5	67 mm Door stile		
		B = 49.0			
		C = 5.0			
		D = 14.0			
E = 27.0					



THE PARKSIDE GROUP LTD

THE WILLOW CENTRE
17 WILLOW LANE, MITCHAM, SURREY, CR4 4NX
Tel: 020-8685 9685 Fax: 020-8646 5096
Email: axim@parksidegroup.co.uk
Web Site: http://www.axim.co.uk

SCALE	NTS @A4
DATE	NOVEMBER 2016
For scaled technical or CAD drawings, please contact AXIM.	