

MOUNTING INSTRUCTIONS

- Determine hand of door and prepare inside of lock and hinge stiles as show.
- If Cylinder Key Lock is to be used, prepare inside and outside of lock stile as shown.
- Insert Rod and Case Assembly into lock stile and secure with (2) 1/4-20 Shoulder Studs.
- If Key Lock is used, insert Cylinder in Mounting Pad and secure with Locking Ring. Install using (2) #8-32x1-23.8mm Flat Head Machine Screws.
- Position Exit Pad over stile and attach Actuator Link to Actuator Pin using Connecting Pin provided. Place on stile over 1/4-20 Shoulder Studs and tighten 3 Socket Head Set Screws to secure in place.

- Adjust length of top and bottom Latch Bolts by turning in or out. When the Panic Arm is fully depressed, the Latch Bolts should be slightly recessed from flush with the top and bottom of the door. NOTE: Flat notch side of Bolt **must** face the outside of the door. Install top and bottom Latch Bolt Guides using (6) #10x12.7mm Flat Head Self-threading Screws.
- Install (2) 1/4-20 Shoulder Studs on hinge stile. Place other Exit Pad over Studs and tighten 3 Socket Head Set Screws to secure in place.
- Prepare header and threshold as shown. If Header and Threshold Strikes are required, install using (4) #8x9.5mm Flat Head Self-threading Screws or (4) #8x25.4mm Flat Head All-purpose screws.

DOGGING EXIT DEVICE USING DOGGING PIN:

Fully depress push paddle and hold, push up Dogging Pin with screwdriver and rotate 90° in either direction.

TO RELEASE EXIT DEVICE:

Hold push paddle down and rotate Dogging Pin with screwdriver in either direction until Dogging Pin releases.

DOGGING EXIT DEVICE USING CYLINDER KEY:

Fully depress push paddle and hold, turn Key clockwise approximately 60°, return Key to centre and remove.

TO RELEASE EXIT DEVICE:

Turn key counterclockwise 90°, return Key to centre and remove.



The Parkside Group Ltd

The Willow Centre
17 Willow Lane, Mitcham, Surrey, CR4 4NX
Tel: 020-8685 9685 Fax: 020-8646 5096
Email: axim@parksidegroup.co.uk
Web Site: www.axim.co.uk

SCALE	NTS @A4
DATE	MARCH 2014

For scaled technical or CAD drawings, please contact AXIM.

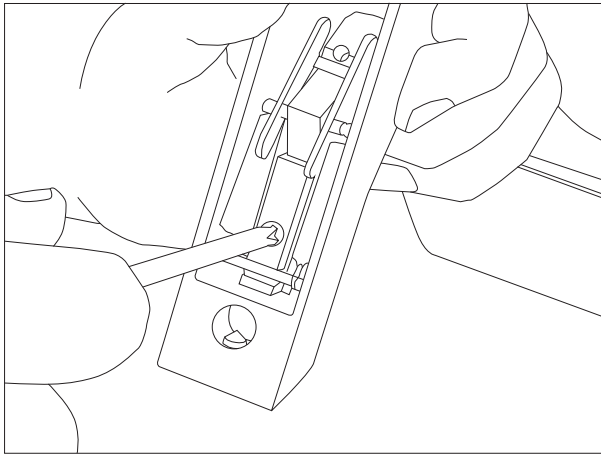

1) Remove securing screw in back of handle unit

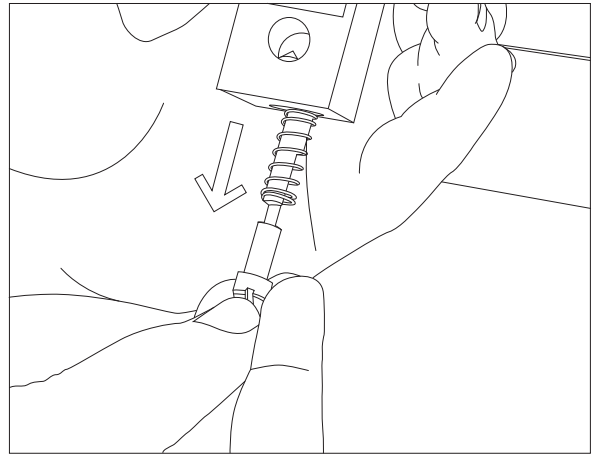

2) Once securing screw is removed existing pin should be ejected by internal spring

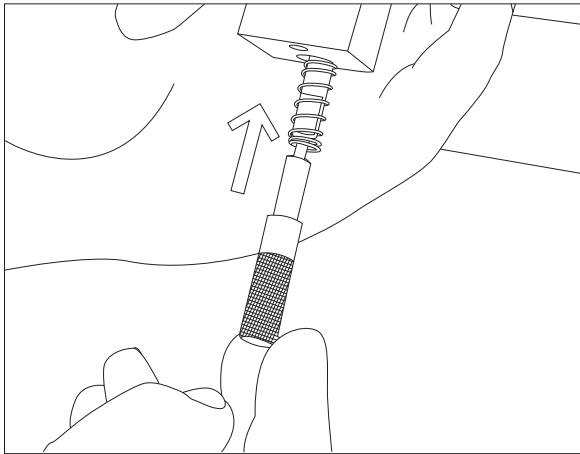

3) Replace existing pin with knurled pin (retaining original spring)

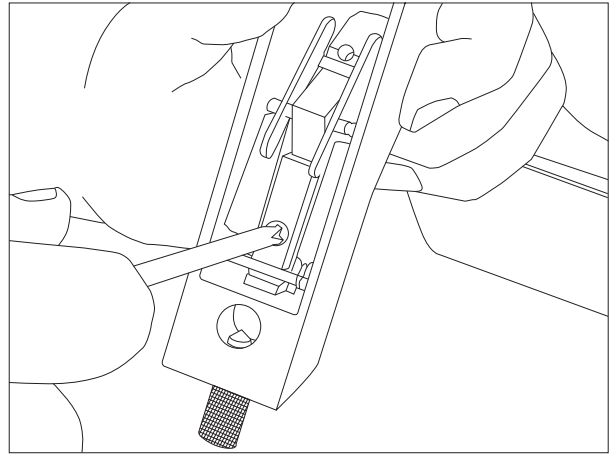

4) Replace securing screw holding knurled pin in far enough that notch on dogging pin can locate on securing screw

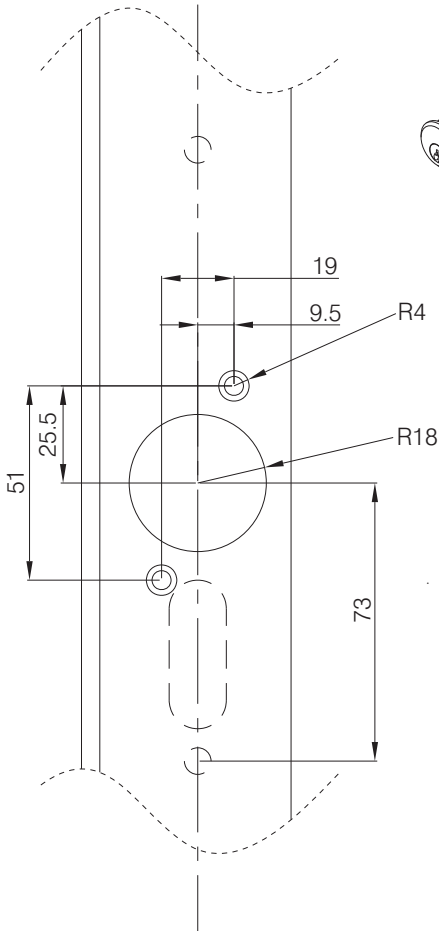
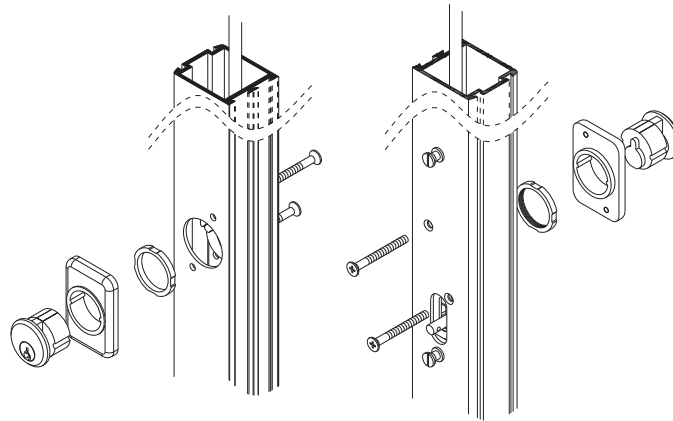
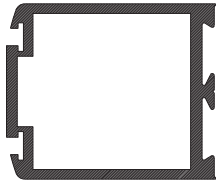

RC-785-AL Rim cylinder & mounting pad for use with 7085/7100 panic exit devices

Rim Cylinder table details		Mounting Pads	Screw Length
RC - 785			
A = 29.5	46mm Door Stile	MP786	S = 57 mm
B = 25.0			
C = 7.0			
D = 12.0			
E = 6.0			
RC - 787		MP790	S = 65 mm
A = 32.5	49mm Door Stile		
B = 28.6			
C = 5.0			
D = 13.0			
E = 10.0			
RC - 789		MP790	S = 65 mm
A = 37.5	54mm Door Stile		
B = 33.6			
C = 7.0			
D = 21.0			
E = 5.0			
RC - 791		MP792	S = 90 mm
A = 53.5	67mm Door Stile		
B = 49.0			
C = 5.0			
D = 14.0			
E = 27.0			



The Parkside Group Ltd

The Willow Centre
17 Willow Lane, Mitcham, Surrey, CR4 4NX
Tel: 020-8685 9685 Fax: 020-8646 5096
Email: axim@parksidegroup.co.uk
Web Site: www.axim.co.uk

SCALE	NTS @A4
DATE	JULY 2017

For scaled technical or CAD drawings, please contact AXIM.

LH-725 Locking handle

Key Controlled Outside trim for use with PR7085, PR7085P, and PR7100 concealed rod Panic Devices.

Uses Axim screw in Mortice cylinder with MS type CAM.

Not handed. (Field reversible).

All Axim Panic Exit Hardware is supplied with comprehensive instructions and full size templates for ease of installation.

Handle rotation 45° anti-clockwise from centre.

OR

Handle rotation 45° clockwise from centre.

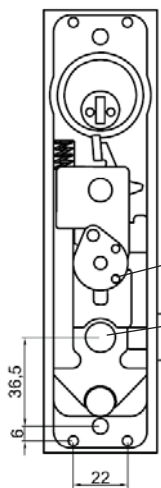
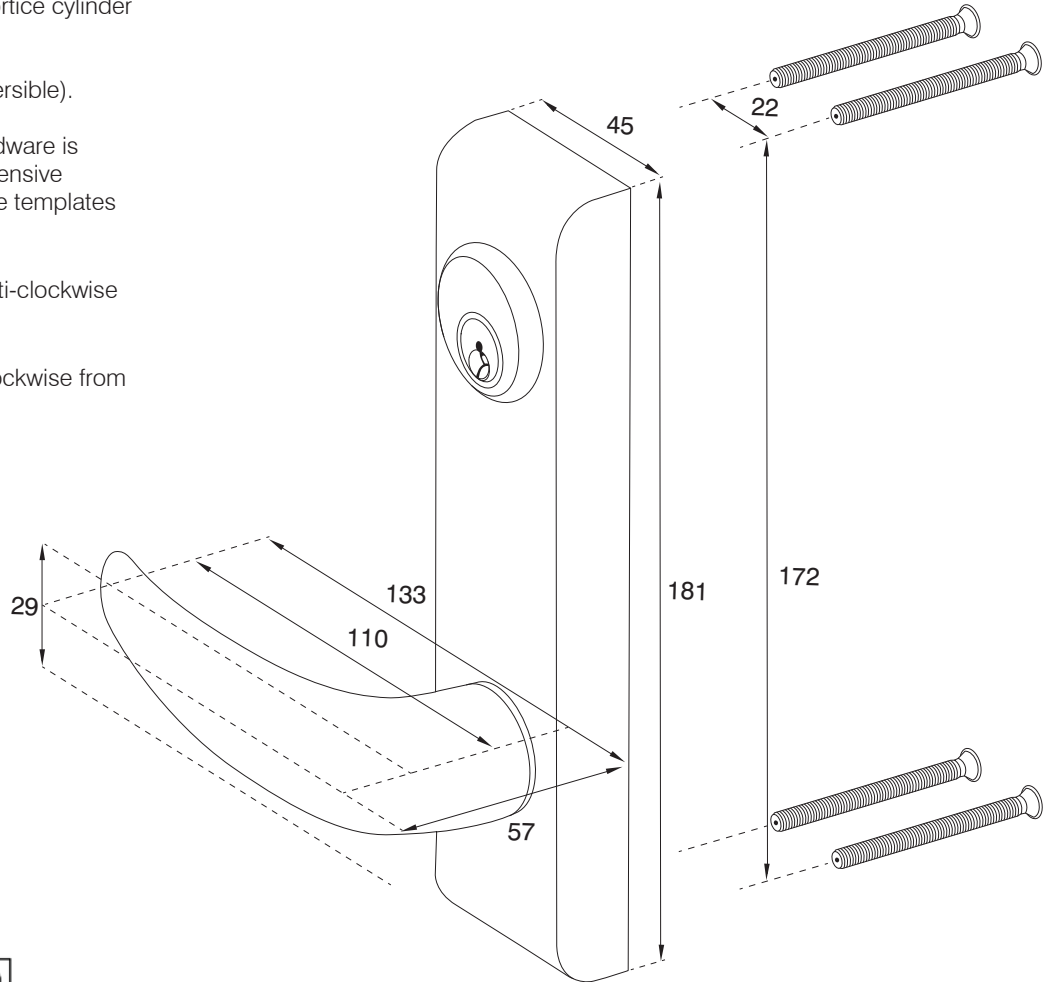

Ensure operating dowel is engaged in slot.

To change the hand of the trim, remove screw and reverse lever. Keep the black side of star washer facing upwards. Ensure screw is locked tight.

Ensure the cylinder and cam operate the lock arm prior to installation.

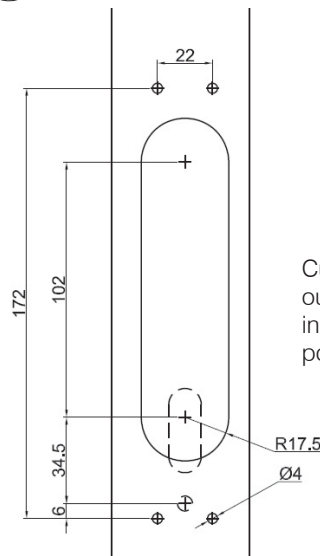

Cutting Prep to fit to outer face. Dashed lines indicate panic exit position (34.5 & 6).



The Parkside Group Ltd

The Willow Centre
17 Willow Lane, Mitcham, Surrey, CR4 4NX
Tel: 020-8685 9685 Fax: 020-8646 5096
Email: axim@parksidegroup.co.uk
Web Site: www.axim.co.uk

SCALE	NTS @A4
DATE	JULY 2017
For scaled technical or CAD drawings, please contact AXIM.	

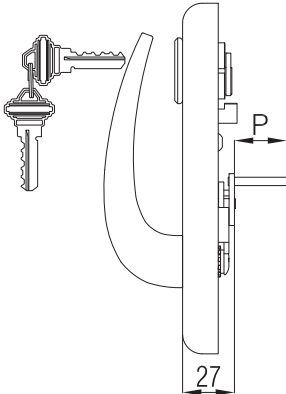

Locking Handle	Pin Length	Door Stile
LH-725	P = 6 mm	46mm
LH-730	P = 9 mm	49mm
LH-740	P = 14 mm	54mm
LH-745	P = 27 mm	67mm

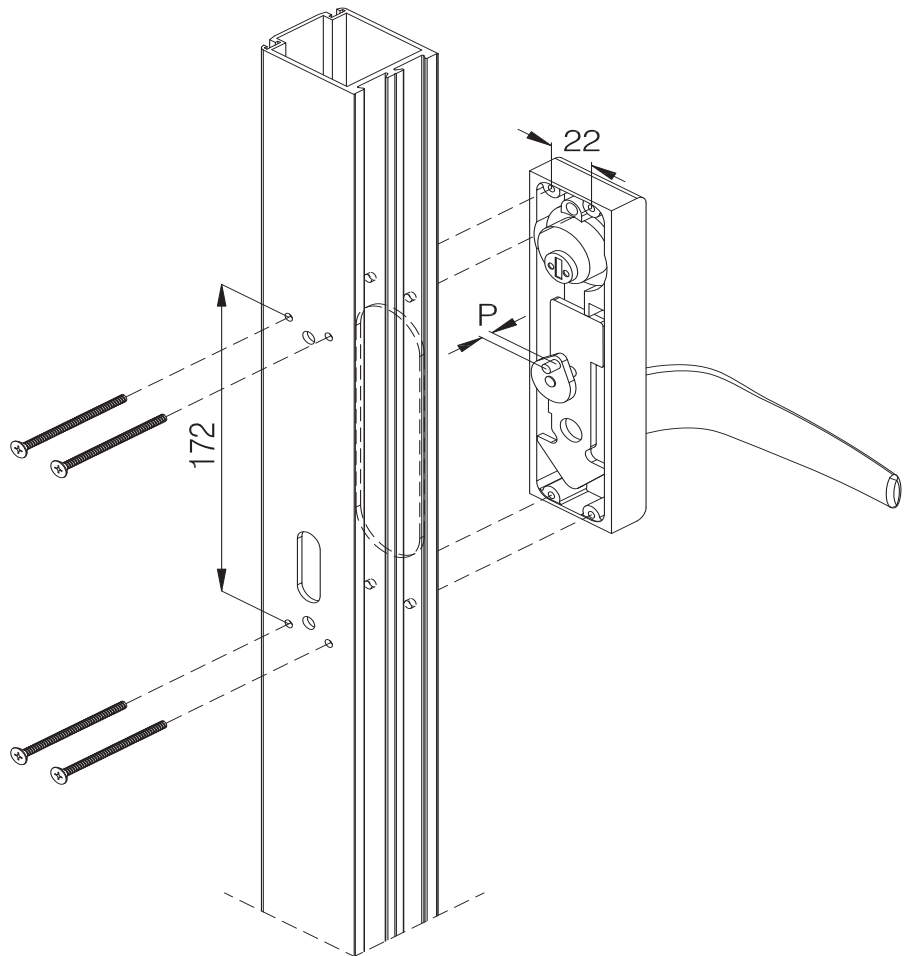
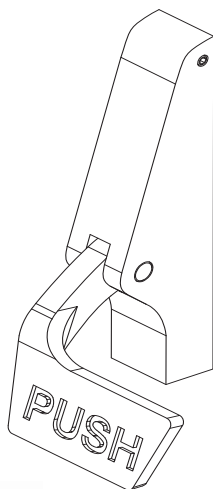
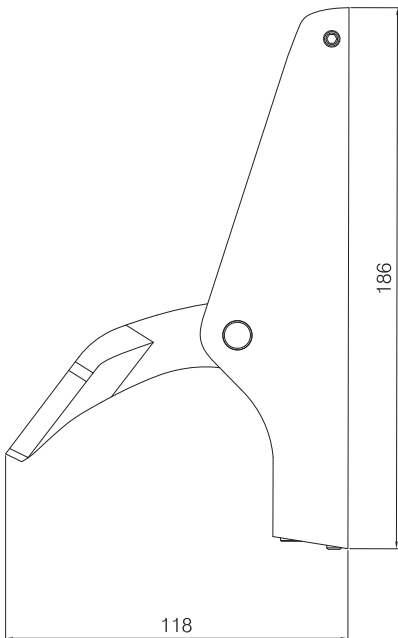

The Parkside Group Ltd

The Willow Centre
17 Willow Lane, Mitcham, Surrey, CR4 4NX
Tel: 020-8685 9685 Fax: 020-8646 5096
Email: axim@parksidegroup.co.uk
Web Site: www.axim.co.uk

SCALE NTS @A4

DATE JULY 2017

For scaled technical or CAD drawings,
please contact AXIM.