

The Fully reversible LK-2100 Standard duty deadlatch range offers flexibility of traffic control during and after business hours.

Fully Reversible Latchbolt Without the need to open the deadlatch case. (Full Instructions included with the product)

Latchbolt Holdback

A reverse Turn of the key while the bolt is held retracted retains the latchbolt in the case, This allows two-way traffic for ideal use in hospitals, banks, shops and any other commercial buildings. which may require :

Free access and exit at certain times, and Controlled access and free exit at other times.

The Axim LK-2100 deadlatch product is an ideal product to be used and specified along with the Axim ES-2100 Electric Strike range offering a remote access control solution for doors.

Alternatively the LK-2100 range can be equally installed with the LK-2100-6515 (48mm) and the LK-2100-7515 (72mm). - see overleaf for ordering codes

Key Points

The Axim Deadlatch is an all metal case complete with the main latch body structure to prevent unauthorised case entry.

The LK-2100 is available with Flat face or Radius face faceplates that are Ordered as separate items - see overleaf for ordering codes.

Fully Reversible Latchbolt without opening the Deadlatch case.

Related Hardware

LK2100 - E
Reversible
Euro Profile Deadlatch

ES2100
Electric Strike

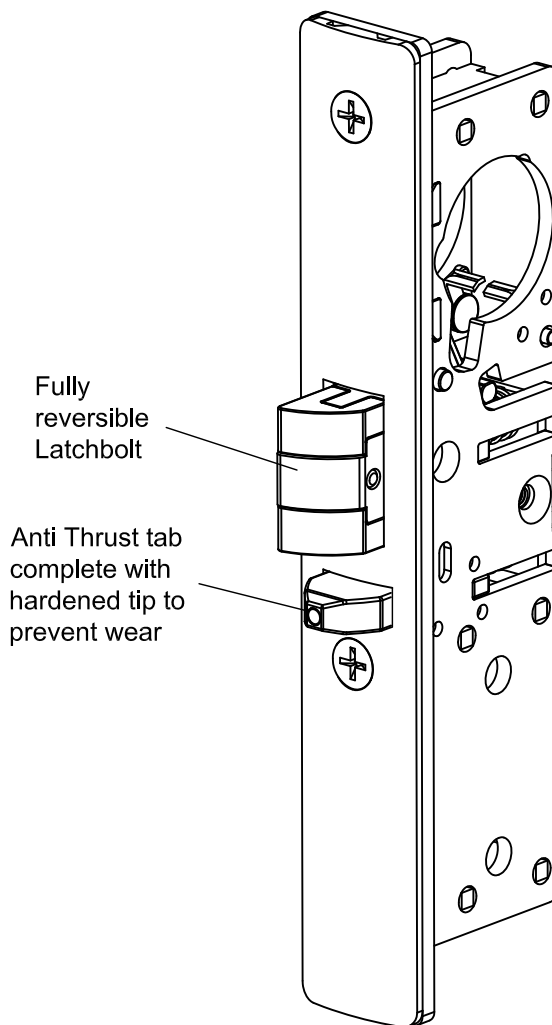

A Nylon Insert is added to the latchbolt to prevent friction in operation.

Suitable for use on Aluminium Doors

Guarantee:
Axim Products are guaranteed for 30 months against defects in material and / or workmanship. This guarantee is Void if the product has been incorrectly specified or installed.



THE PARKSIDE GROUP LTD

THE WILLOW CENTRE
17 WILLOW LANE, MITCHAM, SURREY, CR4 4NX
Tel: 020-8685 9685 Fax: 020-8646 5096
Email: axim@parksidegroup.co.uk
Web Site: <http://www.axim.co.uk>

SCALE	NTS @A4
DATE	AUGUST 2016
For scaled technical or CAD drawings, please contact AXIM.	

It is recommended for Deadlatch that the Fixing Tab (Item LK-2100-77) are included in the Installation. Please order sepertely.

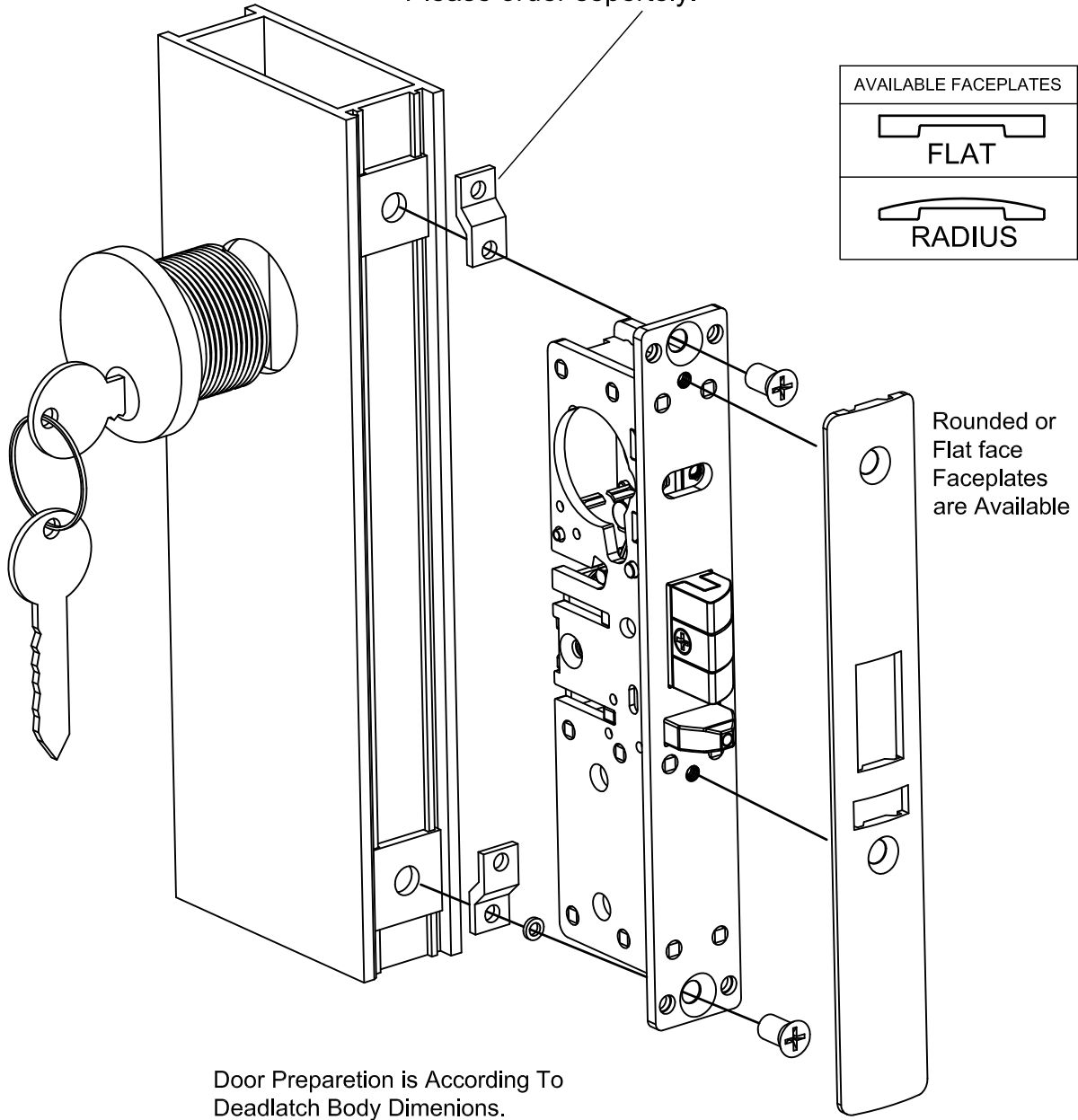

Door Preparation is According To Deadlatch Body Dimensions.



THE PARKSIDE GROUP LTD

THE WILLOW CENTRE
17 WILLOW LANE, MITCHAM, SURREY, CR4 4NX
Tel: 020-8685 9685 Fax: 020-8646 5096
Email: axim@parksidegroup.co.uk
Web Site: <http://www.axim.co.uk>

SCALE	NTS @A4
DATE	AUGUST 2016

For scaled technical or CAD drawings, please contact AXIM.

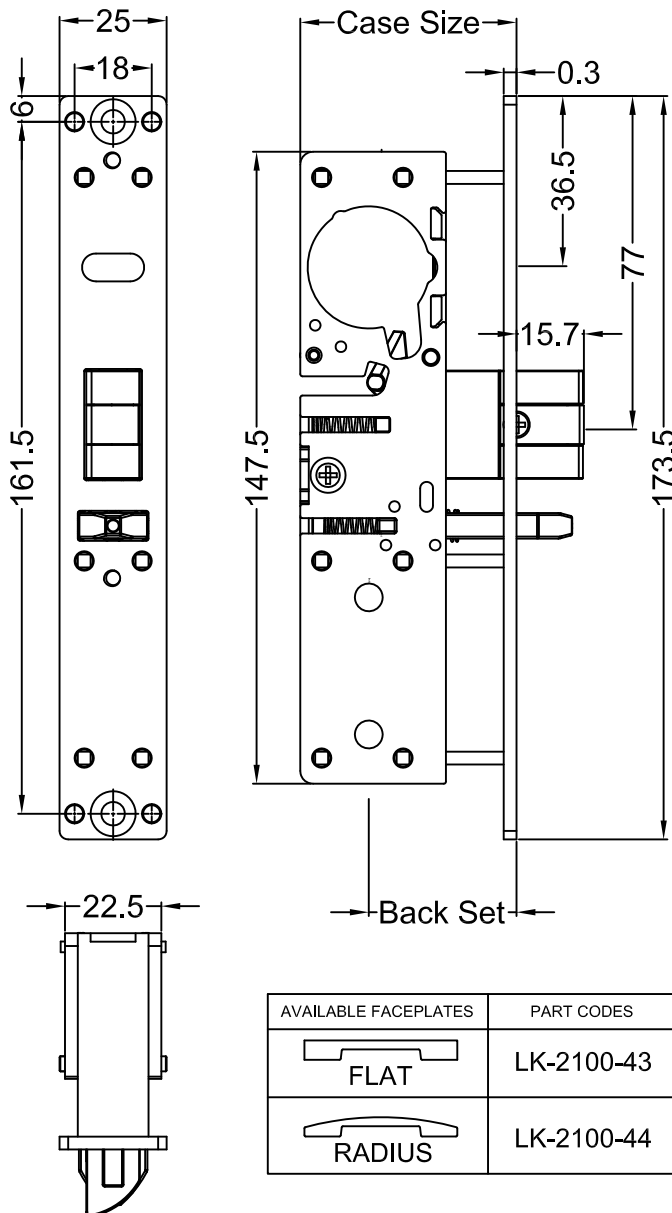

Case Size & Backset vary depending on version:

Backset Options

25mm (31/32") Backset
28mm (1-1/8") Backset
38mm (1-1/2" Backset)

Case:



Steel with corrosion resistant plating.

Latchbolt:

Fully Reversible Latchbolt - Without the need to Open the case.
Latchbolt complete with Hardened Steel Internal Pins.

Faceplate:

173.5 x 25mm
Aluminium material,
Finish: Matt / Satin Anodised Aluminium.

AVAILABLE FACEPLATES	PART CODES
 FLAT	LK-2100-43
 RADIUS	LK-2100-44

Ordering Information

LK-2100-25-E	Euro Profile Deadlatch Case (31/32" Backset)
LK-2100-28-E	Euro Profile Deadlatch Case (1-1/8" Backset)
LK-2100-38-E	Euro Profile Deadlatch Case (1-1/2" Backset)
LK-2100-25-R	Screw in Cylinder Deadlatch Case
LK-2100-28-R	Screw in Cylinder Deadlatch Case
LK-2100-38-R	Screw in Cylinder Deadlatch Case
LK-2100-43	Axim Misc - Flat face plate
LK-2100-44	Axim Misc - Radius face plate
LK-2100-6515	48mm Strike for LK-2100 Reversible Deadlatch
LK-2100-7515	72mm Strike for LK-2100 Reversible Deadlatch
LK-2100-77	Fixing Tab Kit



THE PARKSIDE GROUP LTD

THE WILLOW CENTRE
17 WILLOW LANE, MITCHAM, SURREY, CR4 4NX
Tel: 020-8685 9685 Fax: 020-8646 5096
Email: axim@parksidegroup.co.uk
Web Site: <http://www.axim.co.uk>

SCALE NTS @A4

DATE AUGUST 2016

For scaled technical or CAD drawings,
please contact AXIM.

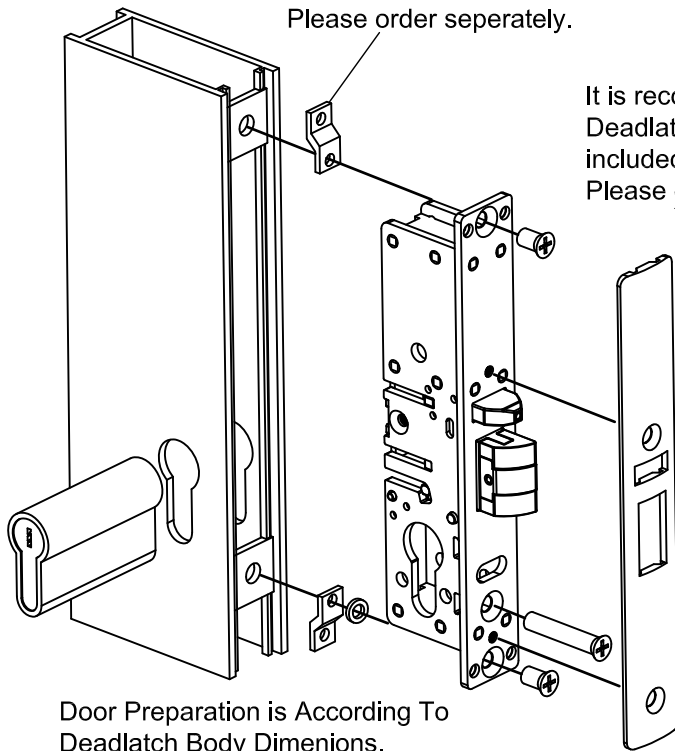

Please order seperately.

It is recommended for Euro Profile and Threaded Cylinder Deadlatch versions that the Fixing Tad (Item LK-2100-77) are included in the Installation. Please order seperately.

Rounded or Flat face Faceplates are Available

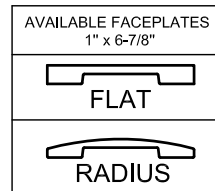

Door Preparation is According To Deadlatch Body Dimensions.

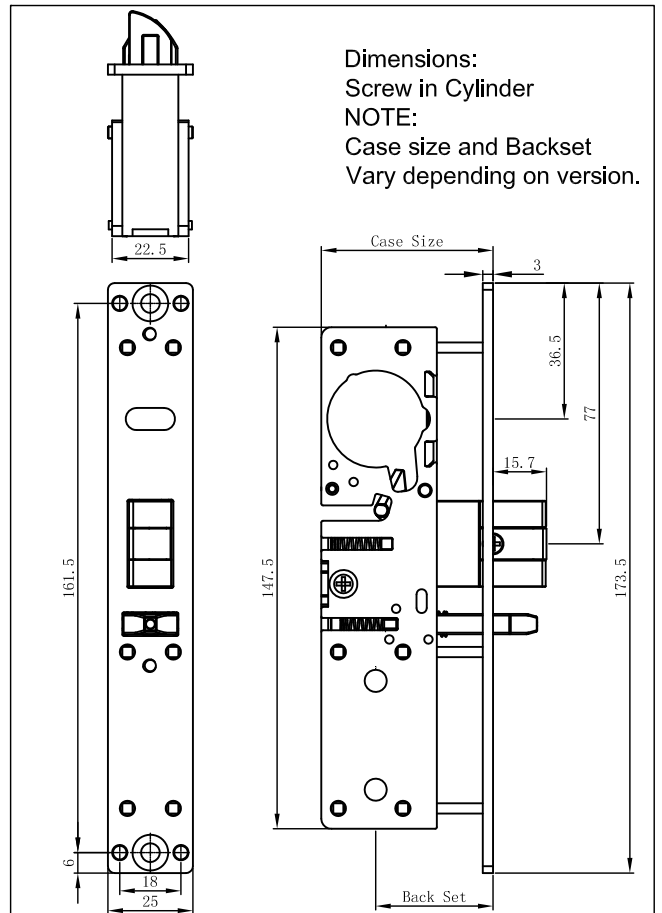
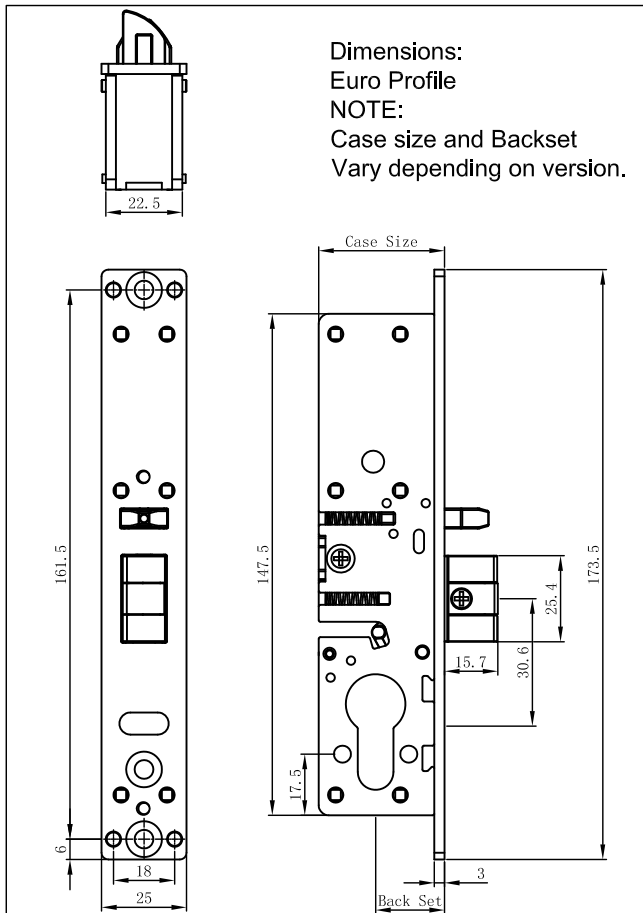

THE PARKSIDE GROUP LTD

THE WILLOW CENTRE
17 WILLOW LANE, MITCHAM, SURREY, CR4 4NX
Tel: 020-8685 9685 Fax: 020-8646 5096
Email: axim@parksidegroup.co.uk
Web Site: <http://www.axim.co.uk>

SCALE	NTS @A4
DATE	AUGUST 2016

For scaled technical or CAD drawings, please contact AXIM.

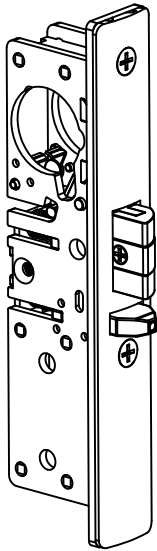

PLEASE NOTE
This product Is Reversible
To Suit Left Hand Or Right Hand
For Handing

Do Not open the case

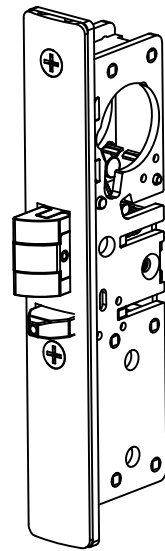

1)

Depress the Latchbolt until the screw in the Side of the Latchbolt can be seen through the hole in the Deadlatch case (larger backset versions allow easier access to this screw).

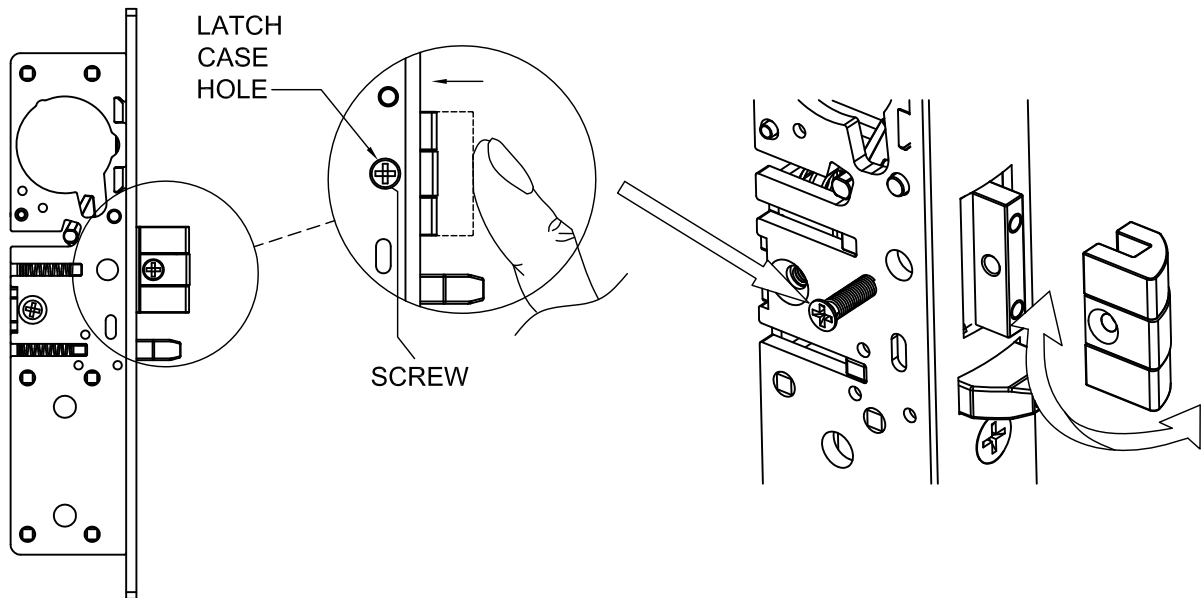

2) Remove the Machine Screw to allow the Latchbolt to be removed.

3) Reverse the Latchbolt and re install ensuring that the screw is replaced securely.

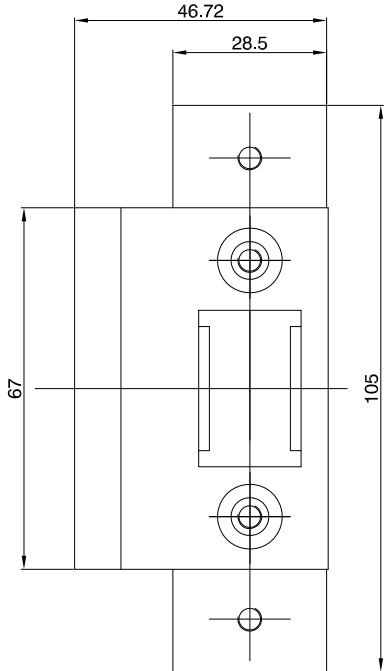

LK-2100-6515
Strike Plate - Flat 48mm

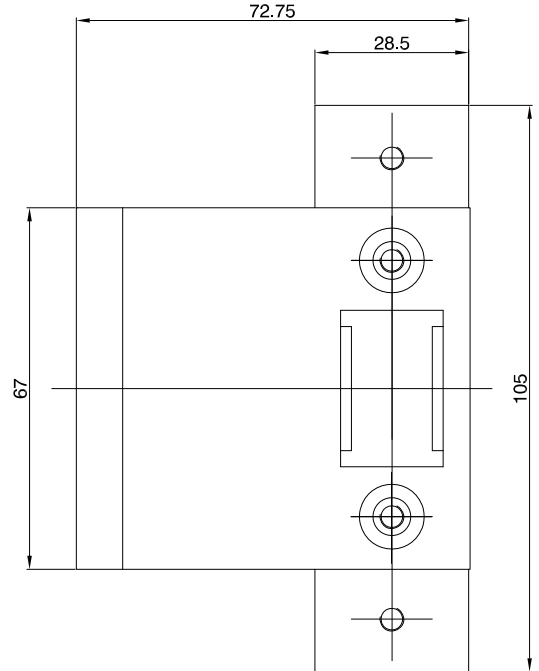

LK-2100-7515
Strike Plate - Flat 72mm

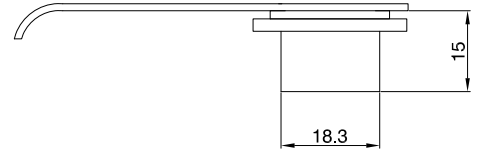
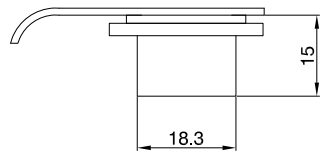

The LK-2100 range can be installed with the LK-2100-6515 flat 48mm strike, or the LK-2100-7515 or the flat 72mm strike.



THE PARKSIDE GROUP LTD

THE WILLOW CENTRE
17 WILLOW LANE, MITCHAM, SURREY, CR4 4NX
Tel: 020-8685 9685 Fax: 020-8646 5096
Email: axim@parksidegroup.co.uk
Web Site: <http://www.axim.co.uk>

SCALE	NTS @A4
DATE	AUGUST 2016
For scaled technical or CAD drawings, please contact AXIM.	