

- A = Mounting screws (back end)
- B = Height adjustment screws (back end)
- C = Regulating valve for closing speed from 180° to 70°
- D = Regulating valve for closing speed from 70° to 0°
- E = Height adjustment screws (front end)
- F = Mounting screws (front end)
- G = Back-spindle dimension.

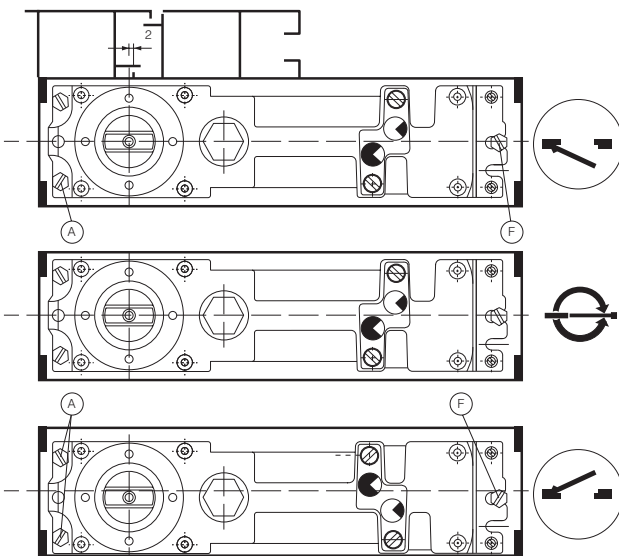

Left-hand door

Loosen mounting screws (A) and (E)
Move closer in cement case as shown.

Double action door

Floor spring should be adjusted
to centre of cement case.

Right-hand door

Loosen mounting screws (A) and (E)
Move closer in cement case as shown.

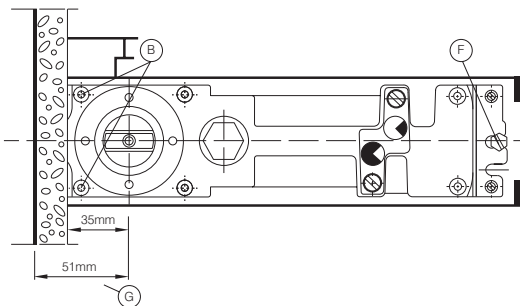

Installation

The back-spindle dimension (G) is 51mm and must be taken into consideration in regard to un-finished, or face concrete walls. After installation dimension (G) can be reduced to 35mm by means of tiles, stucco or other wall finishings.

Removal

Loosen height adjustment screws (B) and remove mounting screws (E). Now remove closer. Re-mounting; re-adjust closer. Tighten mounting screws (E) and height adjustment screw (B).

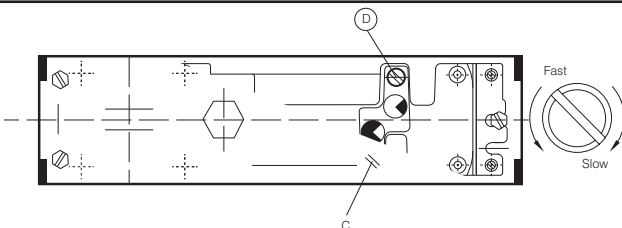

Closing speed

The FS6000 has two closing speeds which are independently adjustable.

Regulating valve C controls the closing speed from 180° ~ 70°.

Regulating valve C = 70° ~ 0° closed.



Accessories Installation drawings showing various accessories are available for all known aluminum-, stainless steel, toughened glass-, wood-, plastic- and steel doors.

THE PARKSIDE GROUP LTD

THE WILLOW CENTRE
17 WILLOW LANE, MITCHAM, SURREY, CR4 4NX
Tel: 020-8685 9685 Fax: 020-8646 5096
Email: axim@parksidegroup.co.uk
Web Site: <http://www.axim.co.uk>

SCALE	NTS @A4
DATE	MARCH 2014
For scaled technical or CAD drawings, please contact AXIM.	

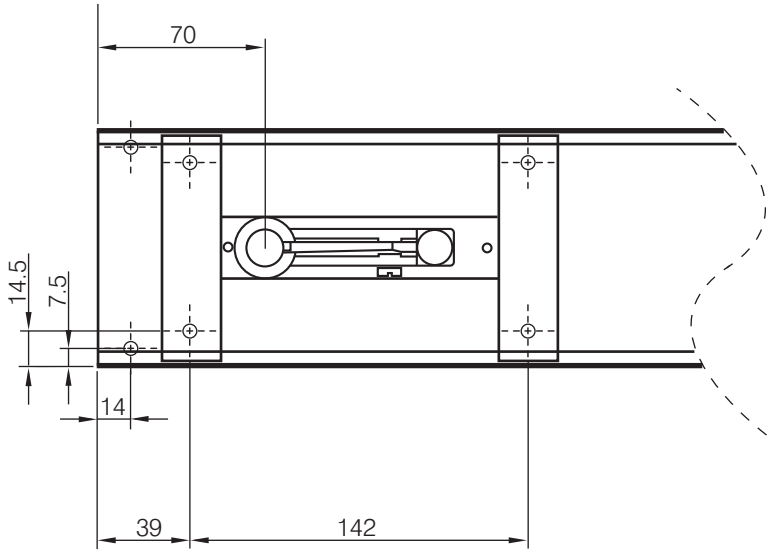

Blocks (by fabricator) drilled and tapped to suit top pivot

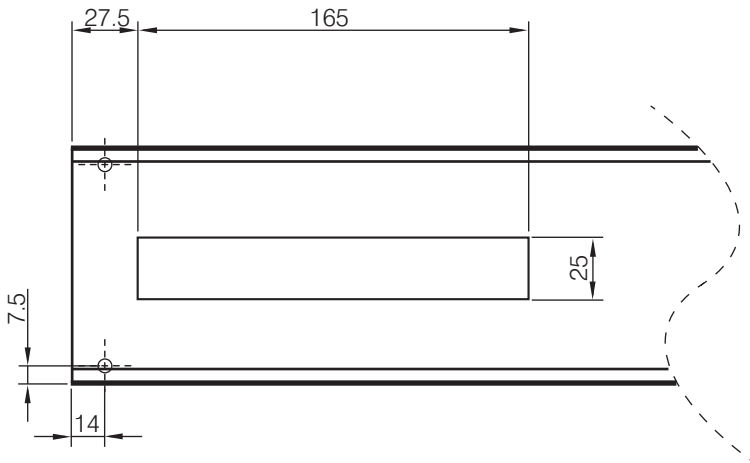
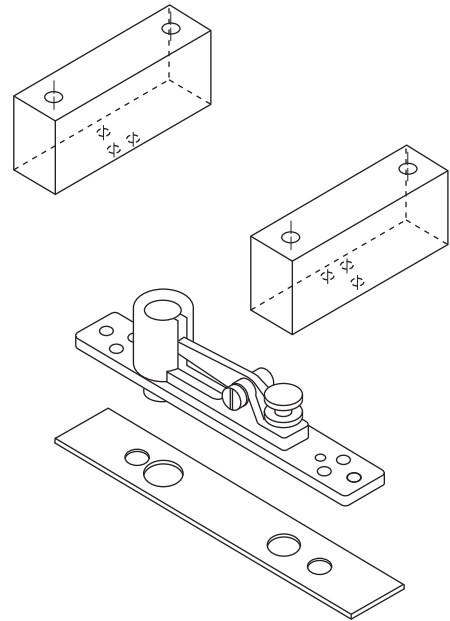

THE PARKSIDE GROUP LTD

THE WILLOW CENTRE
17 WILLOW LANE, MITCHAM, SURREY, CR4 4NX
Tel: 020-8685 9685 Fax: 020-8646 5096
Email: axim@parksidegroup.co.uk
Web Site: <http://www.axim.co.uk>

SCALE NTS @A4

DATE MARCH 2014

For scaled technical or CAD drawings,
please contact AXIM.

Note:
For anti finger trap doors with auto closers
use AXIM TC8800 dummy transom closer with
standard bottom pivot

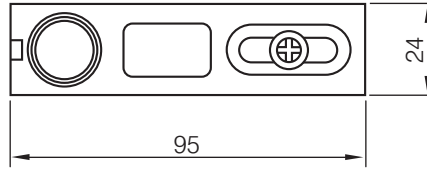

AXIM FS-6000-0115

