

POSITION OF ARMS AND INDEX SETTINGS

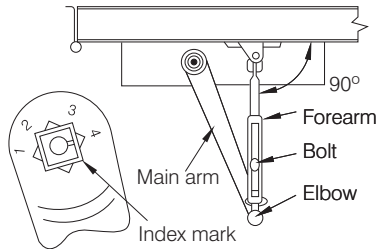

Right hand door. Use index mark 4

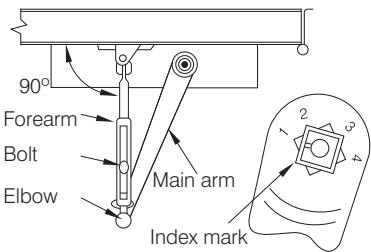

Left hand door. Use index mark 1

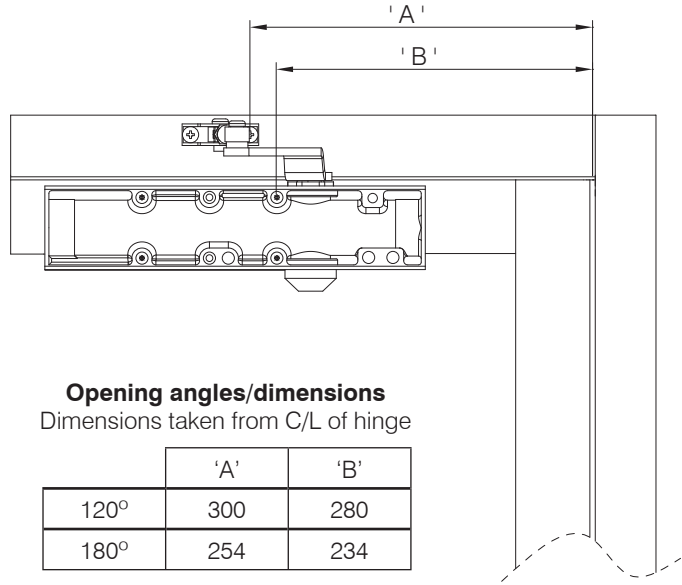

Opening angles/dimensions
Dimensions taken from C/L of hinge

	'A'	'B'
120°	300	280
180°	254	234

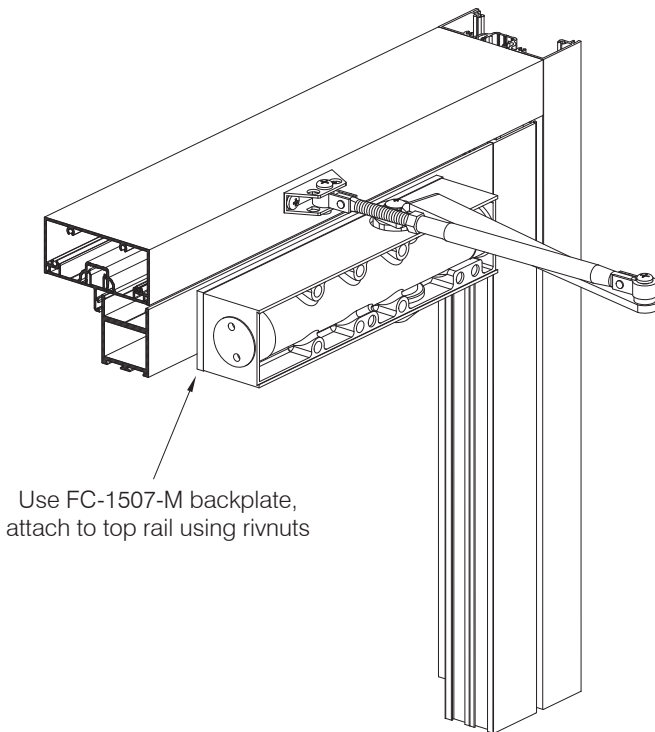

Use FC-1507-M backplate,
attach to top rail using rivnuts

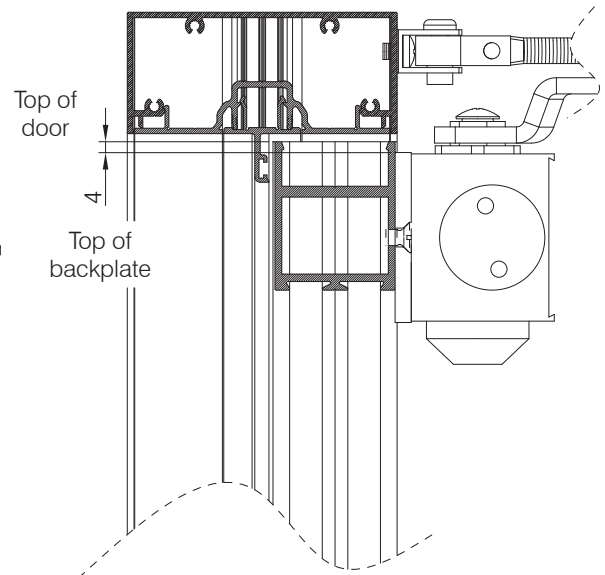

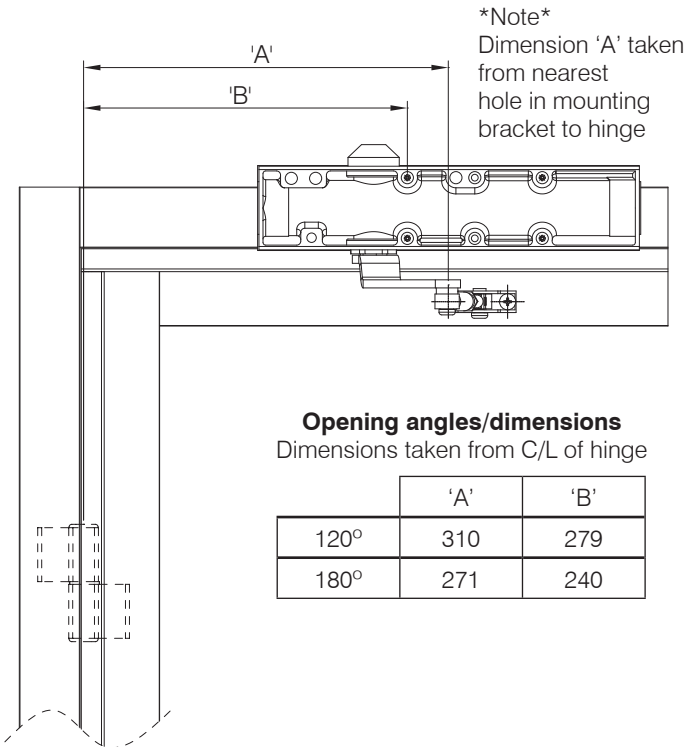

Opening angles/dimensions
Dimensions taken from C/L of hinge

	'A'	'B'
120°	310	279
180°	271	240

POSITION OF ARMS AND INDEX SETTINGS

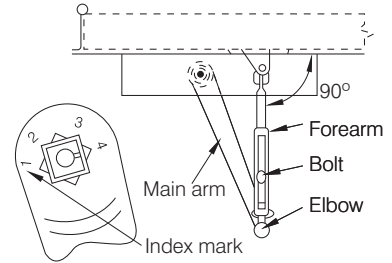

Left hand door. Use index mark 1

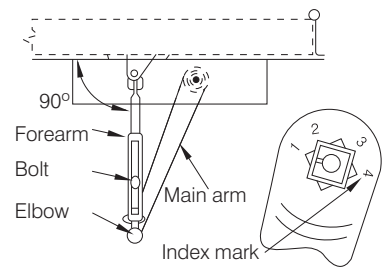

Right hand door. Use index mark 4

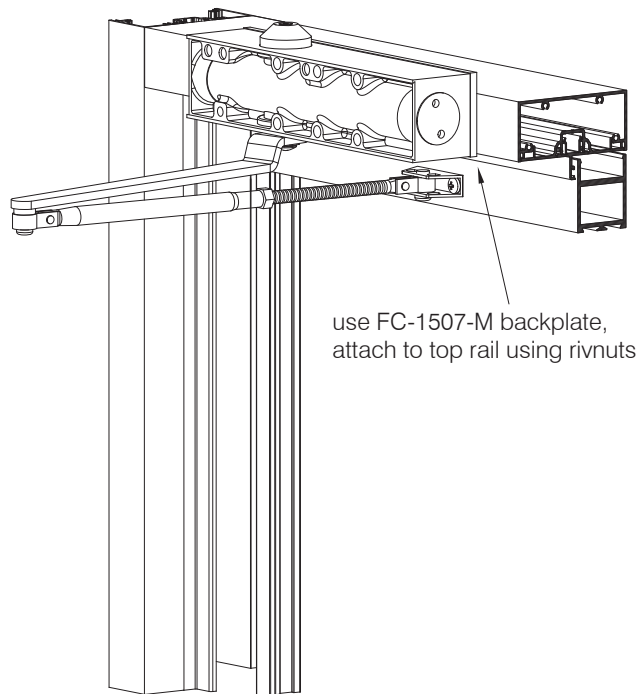
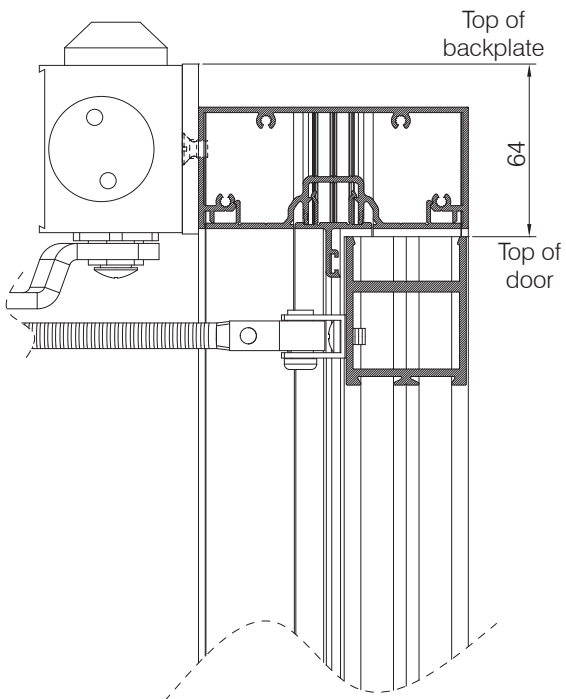

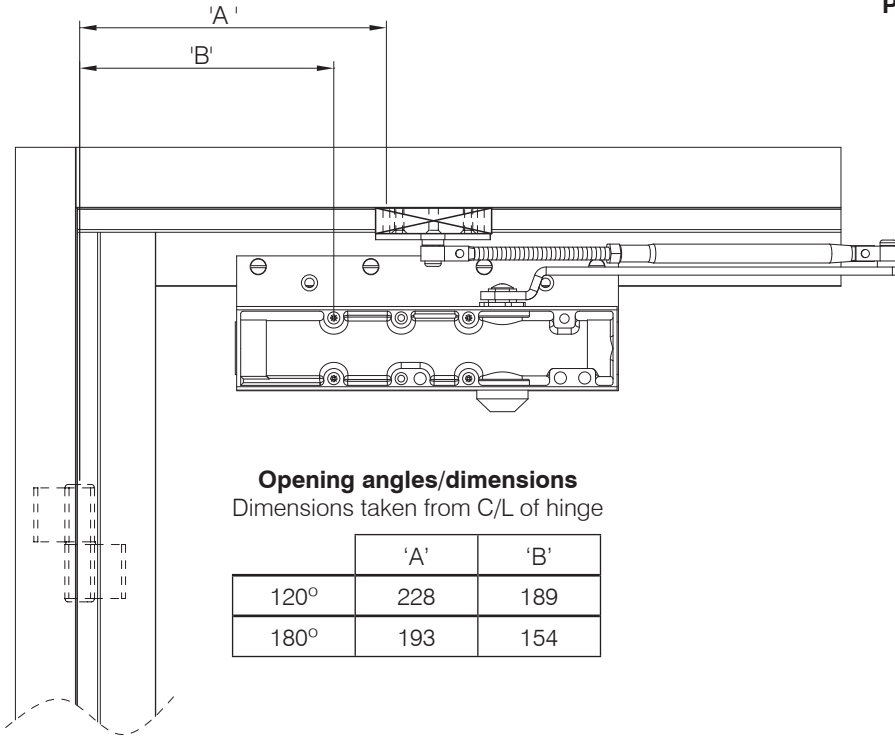

POSITION OF ARMS AND INDEX SETTINGS

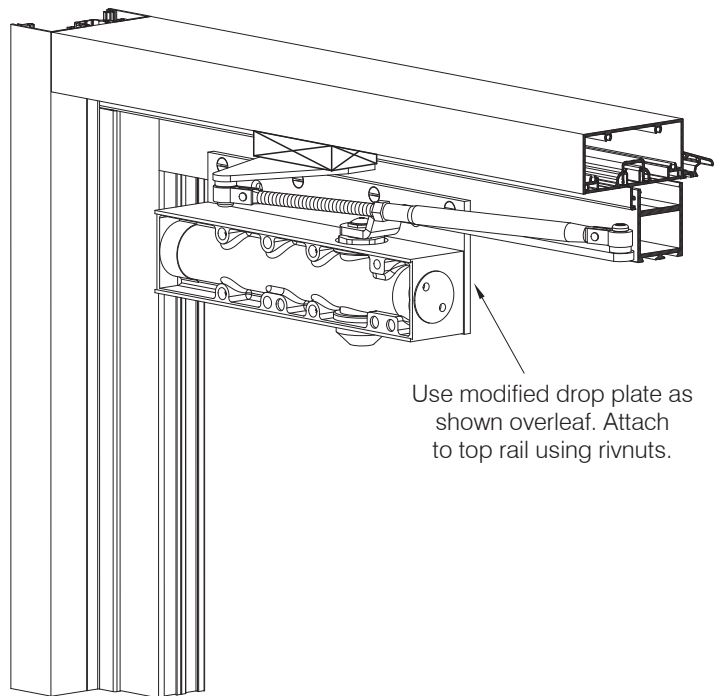
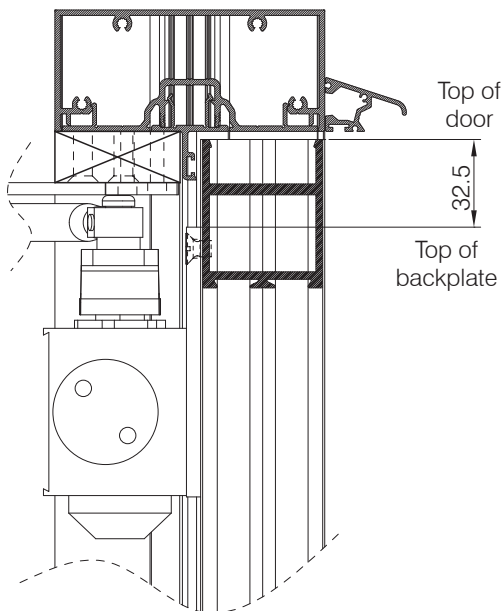
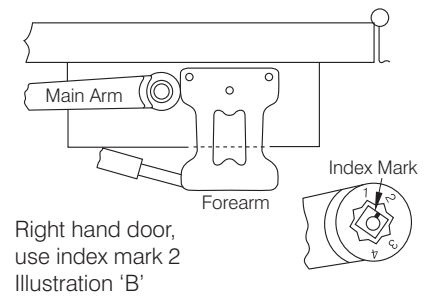
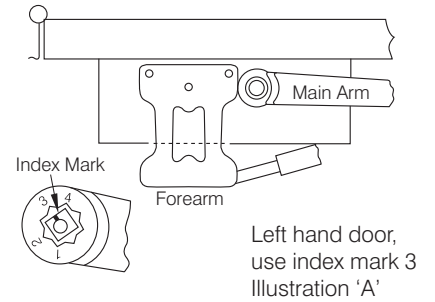

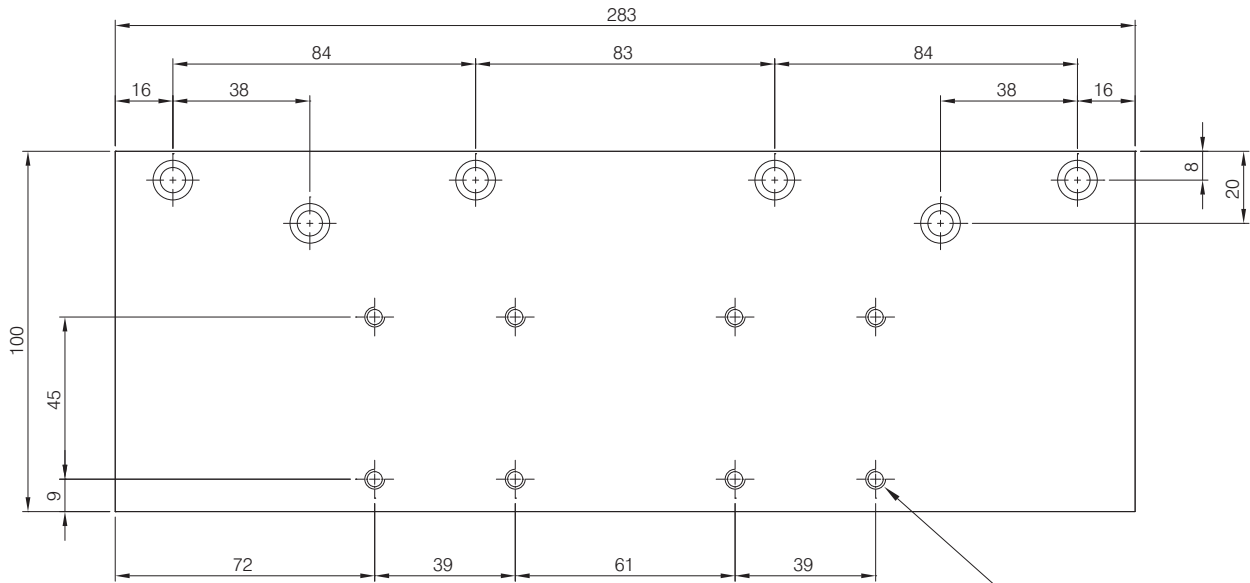

FC-1507-AL

Backplate for use with FC1500 series surface closers on parallel arm installation

8 x M5 tapped holes. Typ.

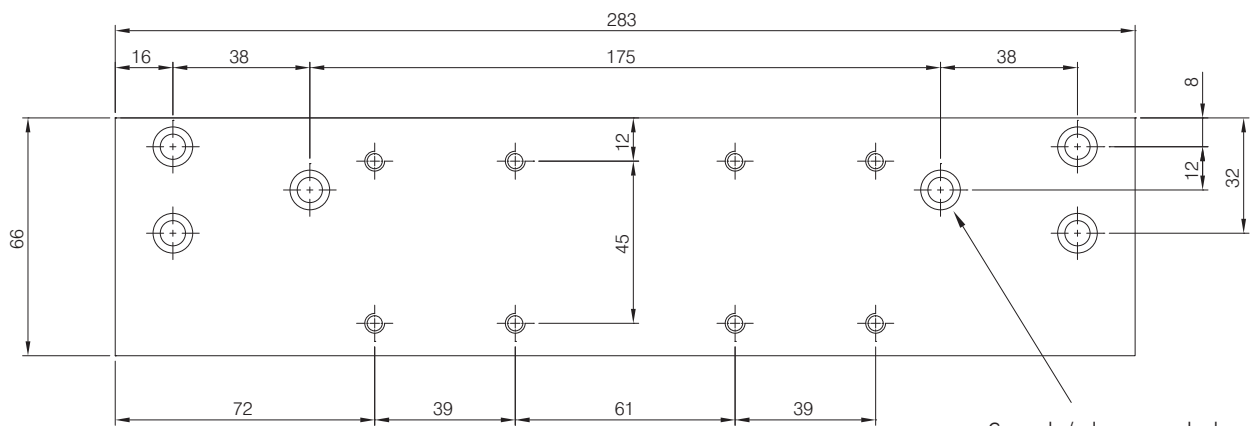

FC-1507-AL-MOD

Backplate for use with FC1500 series surface closers on standard and top jamb installation

6 x csk / clearance holes to suit M6 screws. Typ.



The Parkside Group Ltd

The Willow Centre
17 Willow Lane, Mitcham, Surrey, CR4 4NX
Tel: 020-8685 9685 Fax: 020-8646 5096
Email: axim@parksidegroup.co.uk
Web Site: www.axim.co.uk

SCALE NTS @A4

DATE MARCH 2014

For scaled technical or CAD drawings, please contact AXIM.

ISO view not to scale

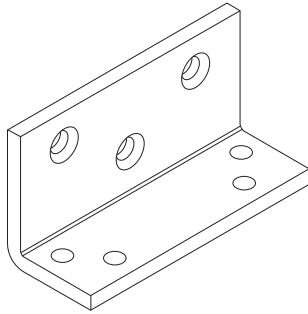

Material: Mild steel
Finish: Zinc plating + silver,
bronze or white PPC

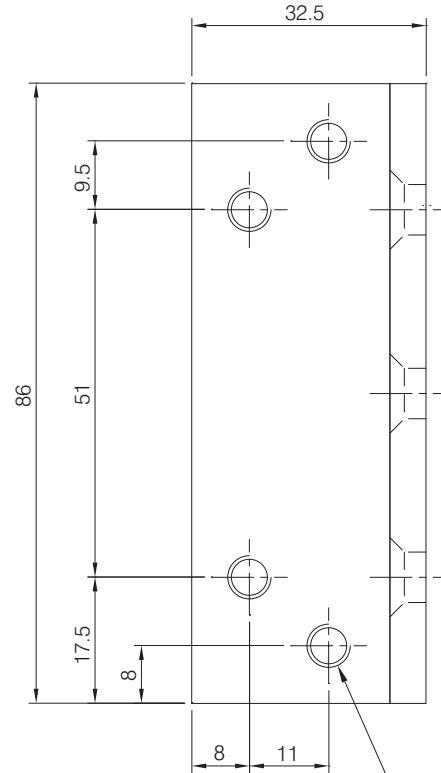

4 x M6 tapped holes

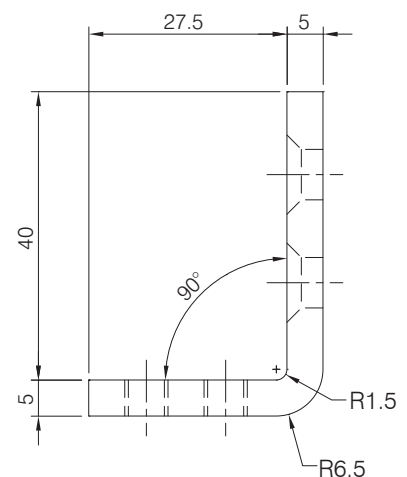
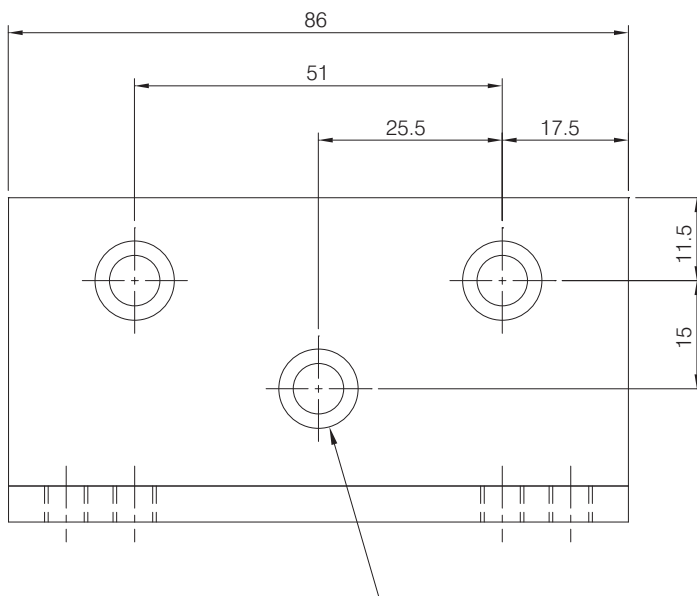

The Parkside Group Ltd

The Willow Centre
17 Willow Lane, Mitcham, Surrey, CR4 4NX
Tel: 020-8685 9685 Fax: 020-8646 5096
Email: axim@parksidegroup.co.uk
Web Site: www.axim.co.uk

SCALE NTS @A4

DATE MARCH 2014

For scaled technical or CAD drawings,
please contact AXIM.

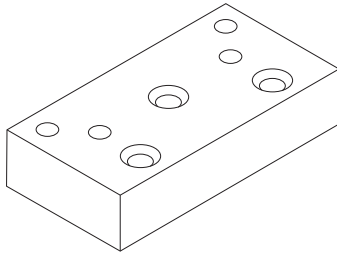

ISO view not to scale

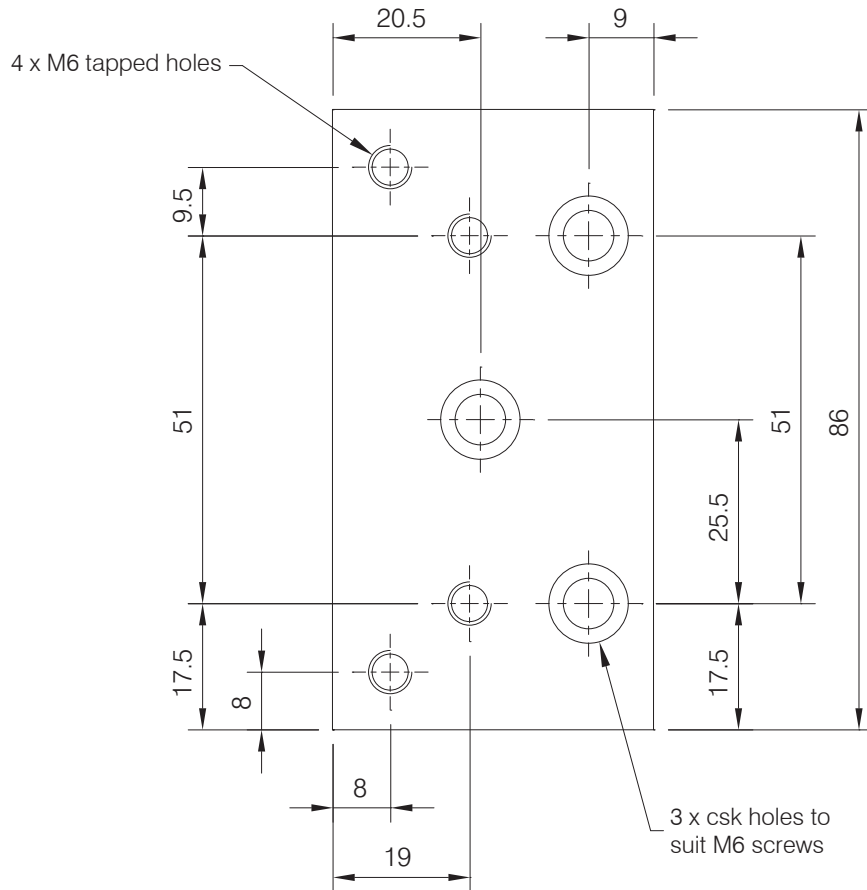
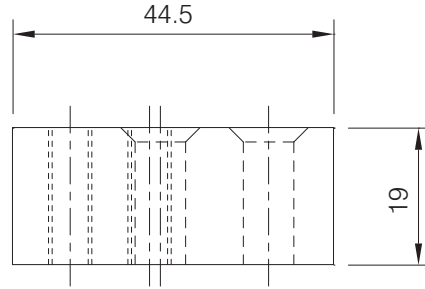

Material: Aluminium
Finish: Mill finish



The Parkside Group Ltd

The Willow Centre
17 Willow Lane, Mitcham, Surrey, CR4 4NX
Tel: 020-8685 9685 Fax: 020-8646 5096
Email: axim@parksidegroup.co.uk
Web Site: www.axim.co.uk

SCALE	NTS @A4
DATE	MARCH 2014
For scaled technical or CAD drawings, please contact AXIM.	

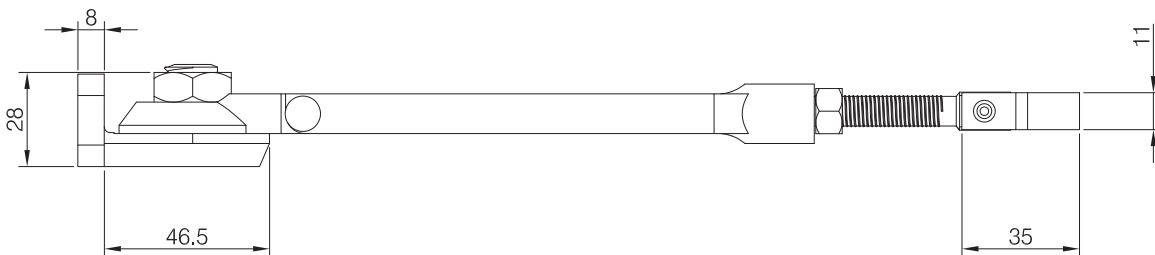
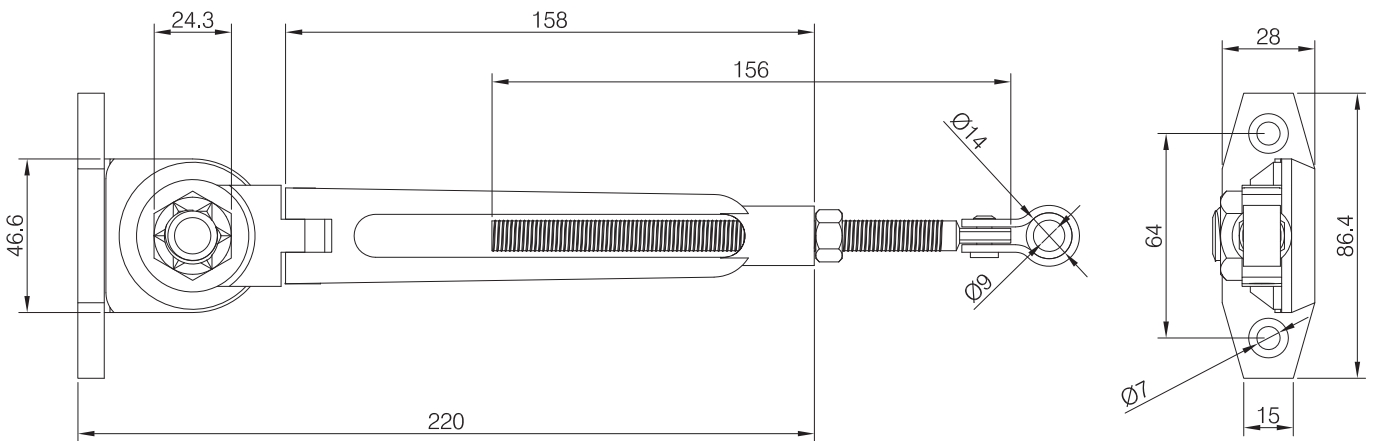
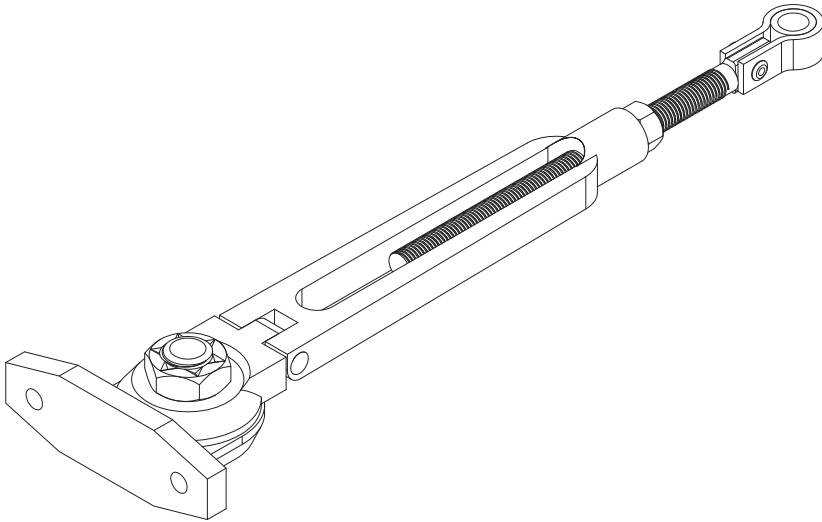

The Parkside Group Ltd

The Willow Centre
17 Willow Lane, Mitcham, Surrey, CR4 4NX
Tel: 020-8685 9685 Fax: 020-8646 5096
Email: axim@parksidegroup.co.uk
Web Site: www.axim.co.uk

SCALE NTS @A4

DATE MAY 2018

For scaled technical or CAD drawings,
please contact AXIM.

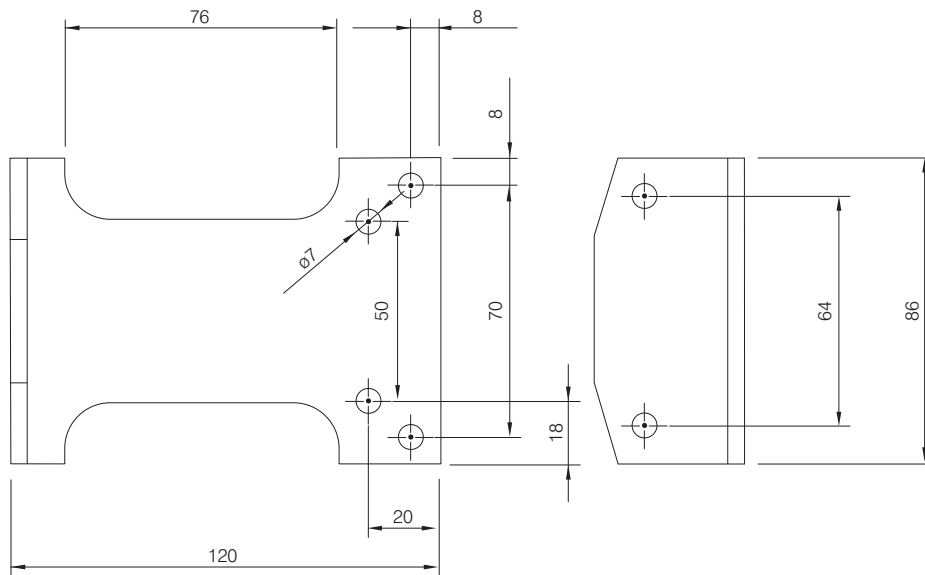
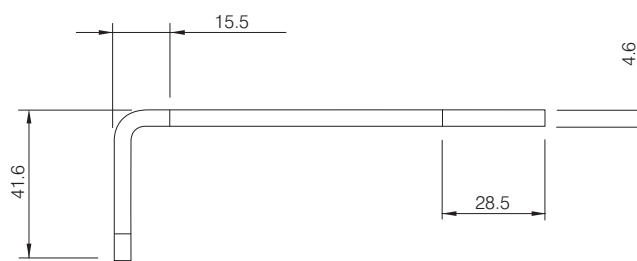
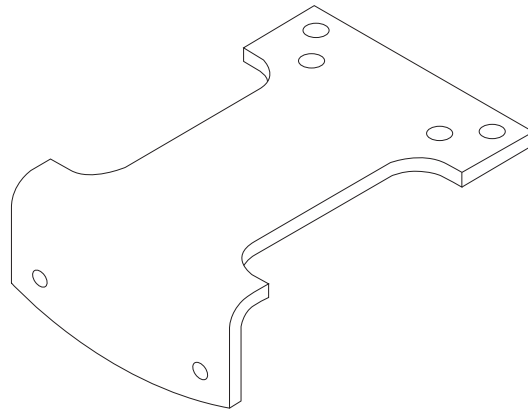

The Parkside Group Ltd

The Willow Centre
 17 Willow Lane, Mitcham, Surrey, CR4 4NX
 Tel: 020-8685 9685 Fax: 020-8646 5096
 Email: axim@parksidegroup.co.uk
 Web Site: www.axim.co.uk

SCALE	NTS @A4
DATE	MARCH 2014
For scaled technical or CAD drawings, please contact AXIM.	

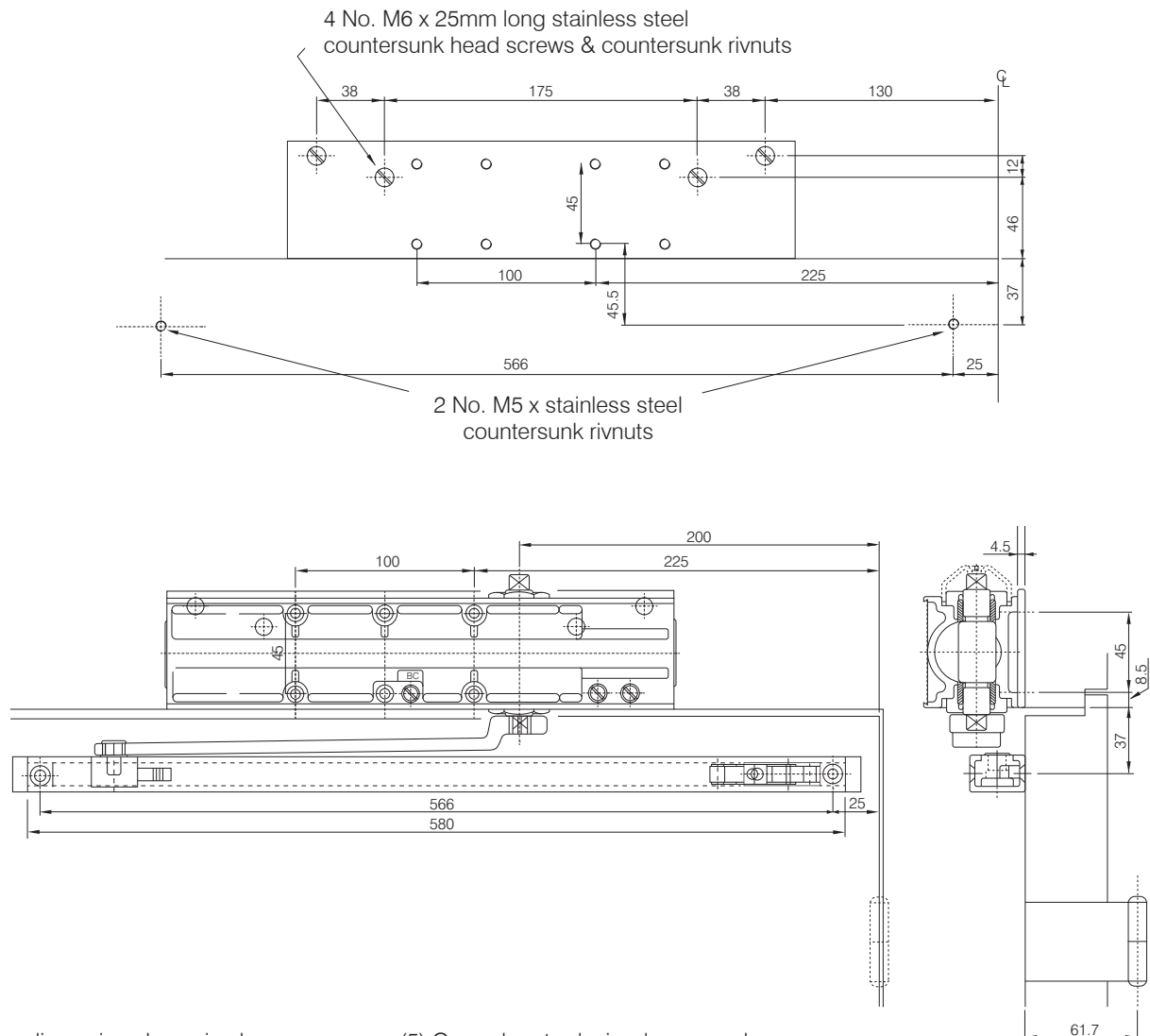

- (1) Use dimension shown in above template to mark six holes on door for door closer and two holes for sliding channel.
- (2) Drill holes in door for 4 - #10 wood screw or drill and tape for 4--M5 x 0.8 (10 x 24) machine screw.
- (3) Drill holes in frame for 2 - #10 wood screw or drill and tape for 2--M5 x 0.8 (10 x 24) machine screw.
- (4) Mount closer and sliding channel, place arm on shaft about 55° from parallel position (as drawing), force arm to parallel position and use ⑤ screw to attached arm & ④ sliding block.

- (5) Open door to desire degree and move the hold open device to be in touch with the sliding block. Tighten the ② adjustment screw.

- (6) For adjusting hold-open force, pls adjust the ③ nut -- clockwise for increasing force & counterclockwise for decreasing. (③ nut can't be adjusted over 2 turns.)

Note: If hold open function is not necessary, please don't install the 'hold open device' into channel.

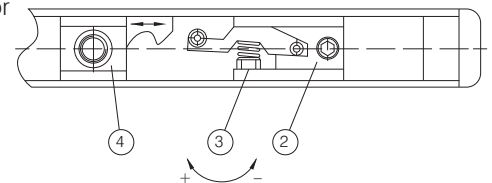

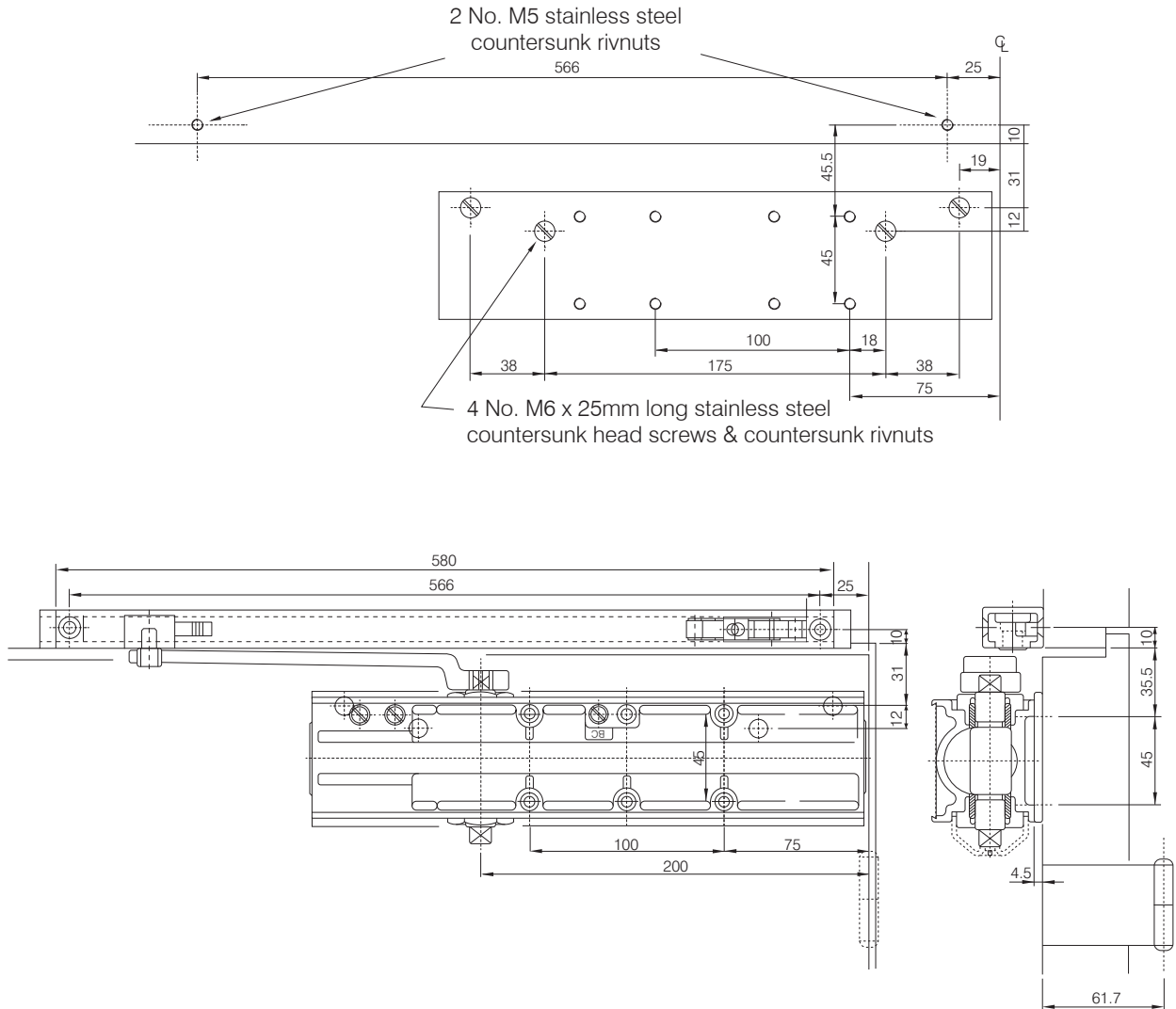

- (1) Use dimension shown in above template to mark six holes on door for door closer and two holes for sliding channel.
- (2) Drill holes in door for 4 - #10 wood screw or drill and tape for 4--M5 x 0.8 (10 x 24) machine screw.
- (3) Drill holes in frame for 2 - #10 wood screw or drill and tape for 2--M5 x 0.8 (10 x 24) machine screw.
- (4) Mount closer and sliding channel, place arm on shaft about 55° from parallel position (as drawing), force arm to parallel position and use ⑤ screw to attached arm & ④ sliding block.

- (5) Open door to desire degree and move the hold open device to be in touch with the sliding block. Tighten the ② adjustment screw.

- (6) For adjusting hold-open force, pls adjust the ③ nut -- clockwise for increasing force & counterclockwise for decreasing. (③ nut can't be adjusted over 2 turns.)

Note: If hold open function is not necessary, please don't install the 'hold open device' into channel.

