

**POSITION OF ARMS AND INDEX SETTINGS**

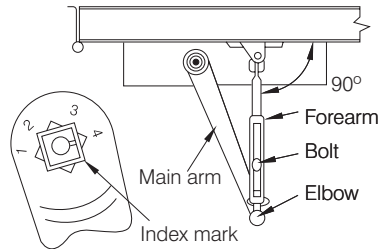

Right hand door. Use index mark 4

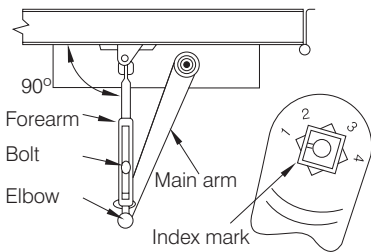

Left hand door. Use index mark 1

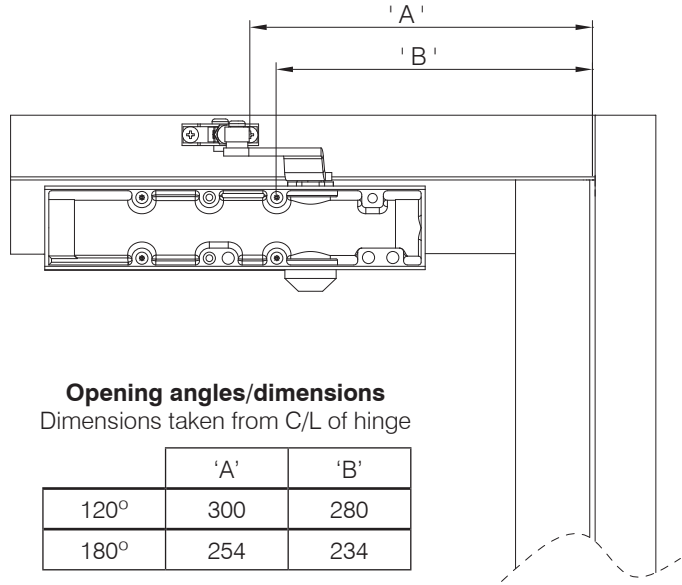

**Opening angles/dimensions**  
Dimensions taken from C/L of hinge

	'A'	'B'
120°	300	280
180°	254	234

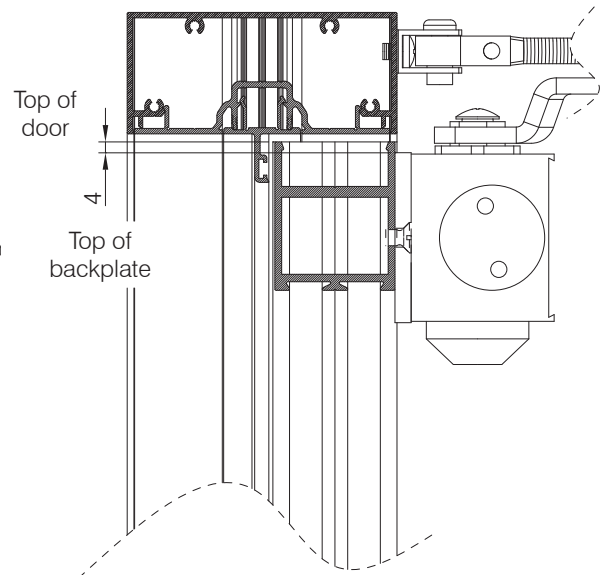
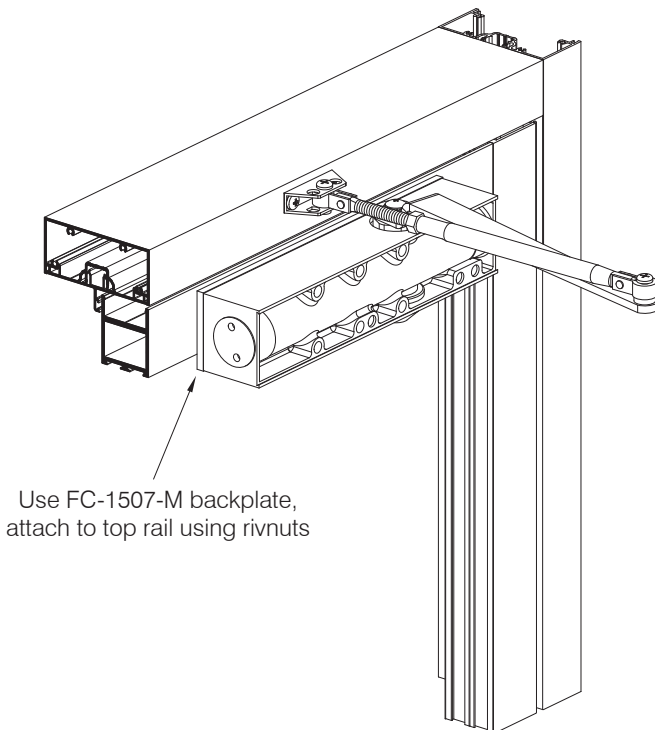

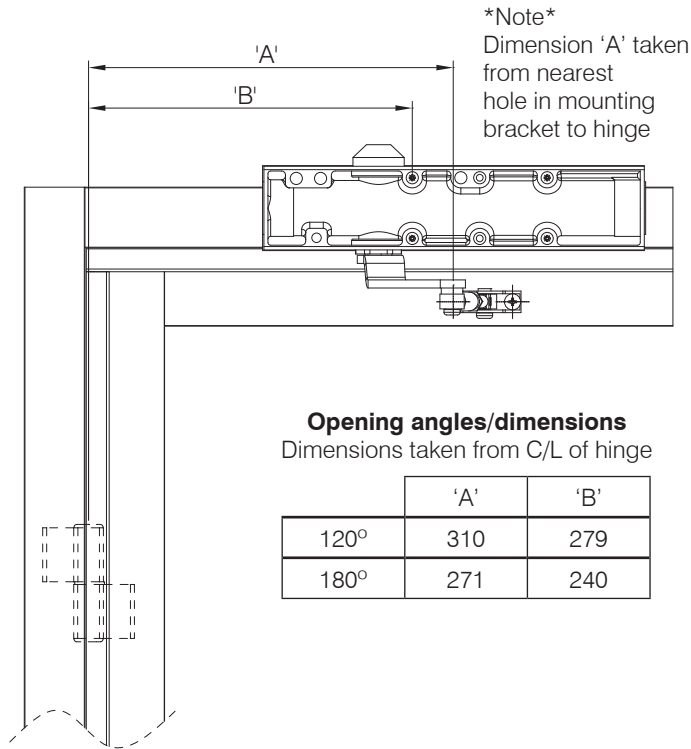

**POSITION OF ARMS AND INDEX SETTINGS**

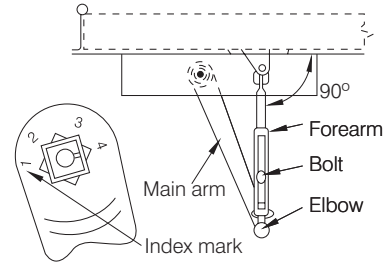

Left hand door. Use index mark 1

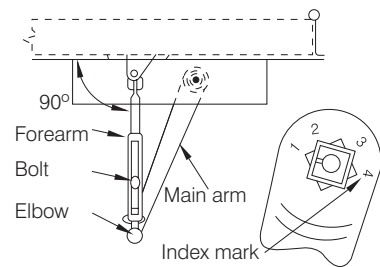

Right hand door. Use index mark 4

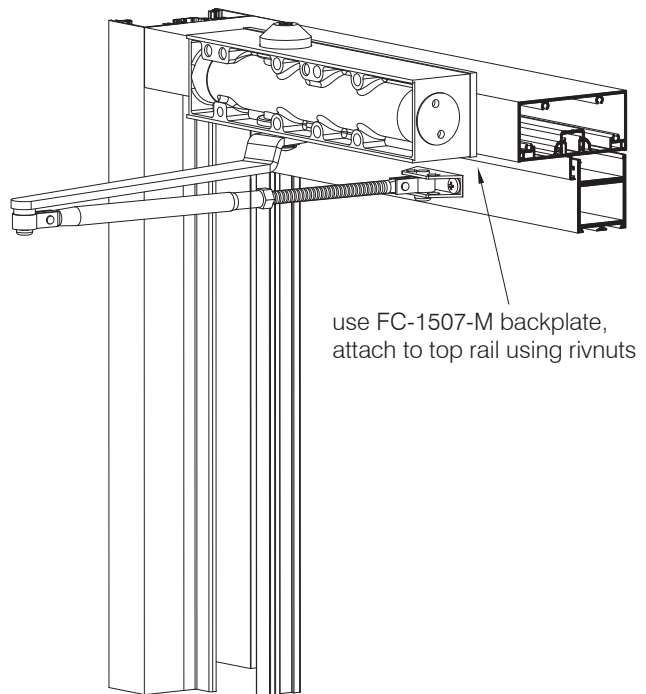
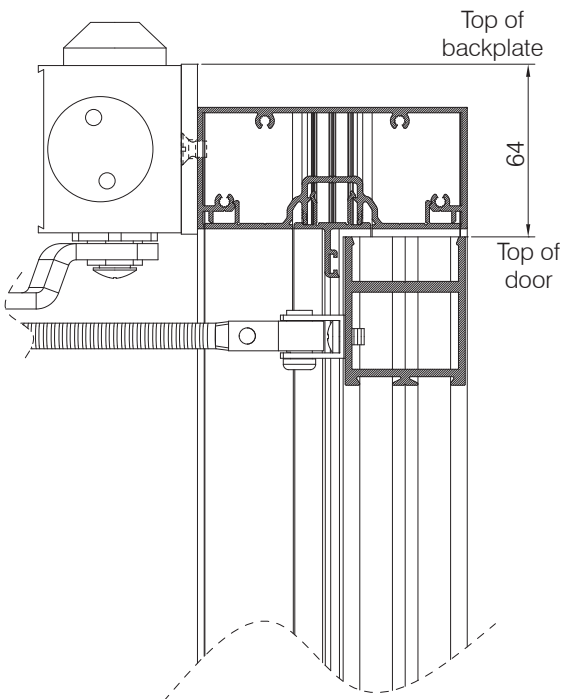

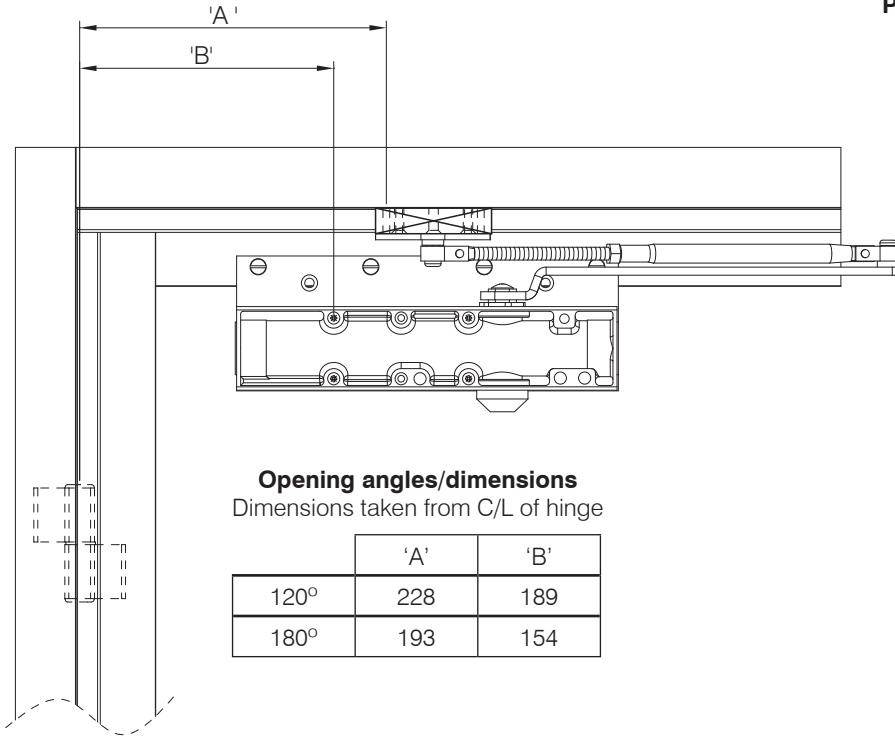

**Opening angles/dimensions**  
Dimensions taken from C/L of hinge

	'A'	'B'
120°	228	189
180°	193	154

**POSITION OF ARMS AND INDEX SETTINGS**

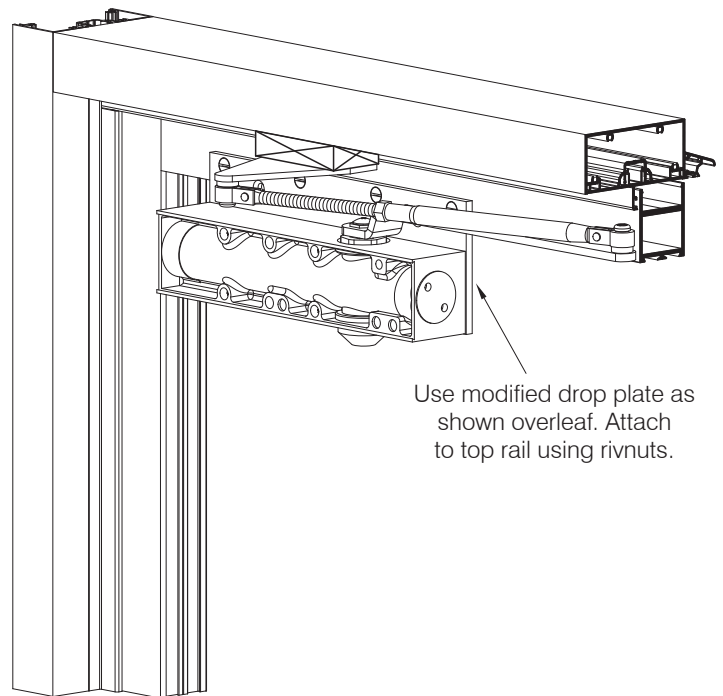
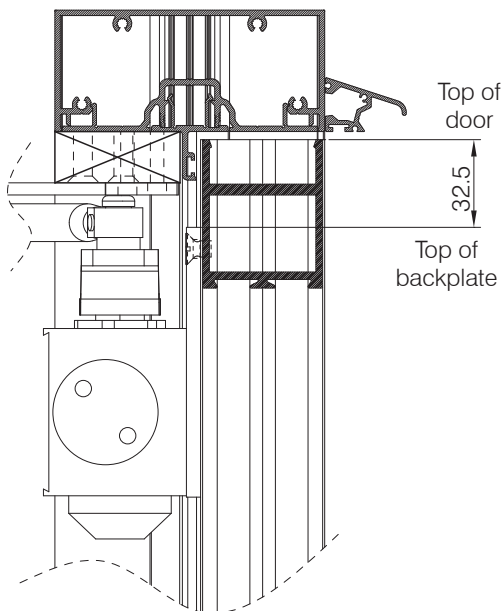
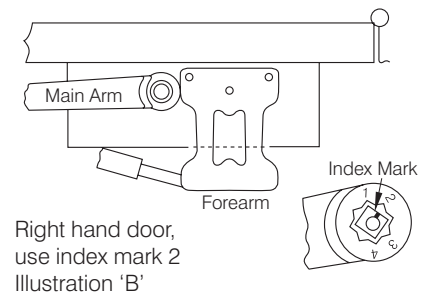
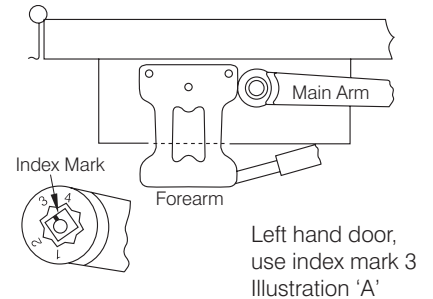

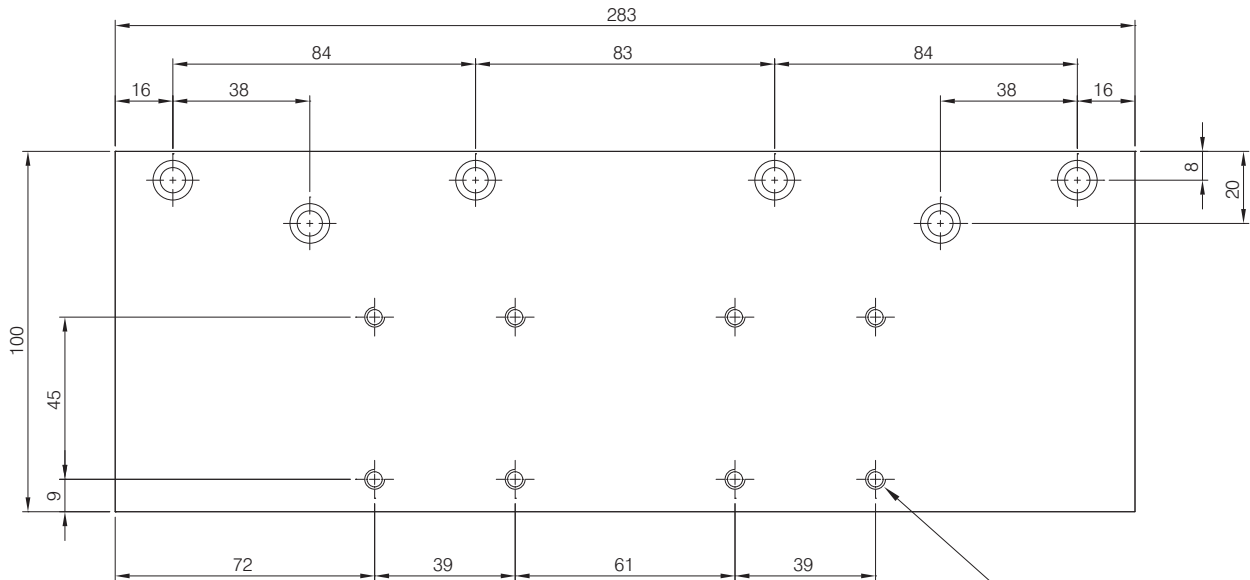

**FC-1507-AL**

Backplate for use with FC1500 series surface closers on parallel arm installation

8 x M5 tapped holes. Typ.

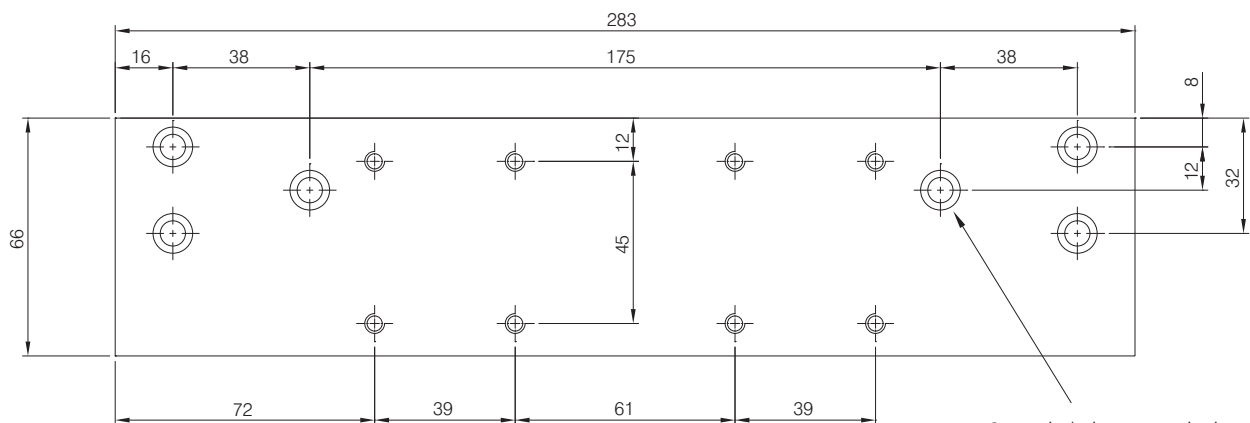

**FC-1507-AL-MOD**

Backplate for use with FC1500 series surface closers on standard and top jamb installation

6 x csk / clearance holes to suit M6 screws. Typ.



**THE PARKSIDE GROUP LTD**

THE WILLOW CENTRE  
17 WILLOW LANE, MITCHAM, SURREY, CR4 4NX  
Tel: 020-8685 9685 Fax: 020-8646 5096  
Email: axim@parksidegroup.co.uk  
Web Site: <http://www.axim.co.uk>

SCALE NTS @A4

DATE MARCH 2014

For scaled technical or CAD drawings, please contact AXIM.

ISO view not to scale

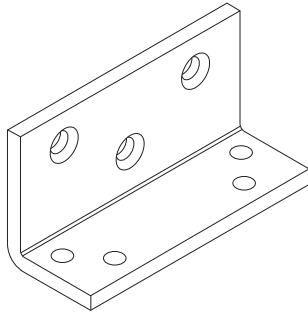

**Material:** Mild steel  
**Finish:** Zinc plating + silver,  
bronze or white PPC

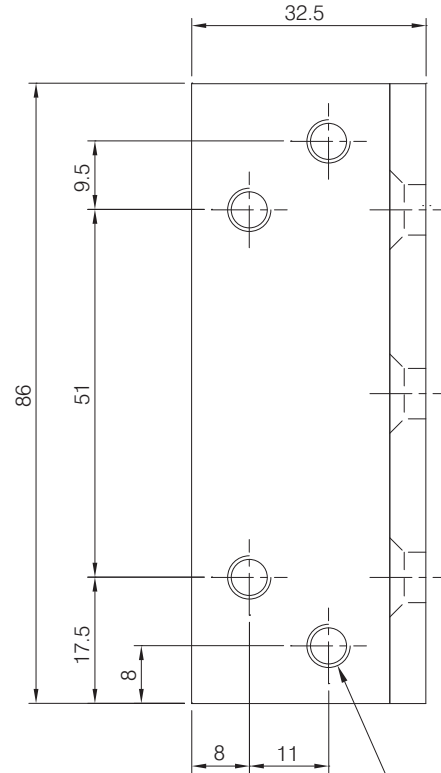

4 x M6 tapped holes

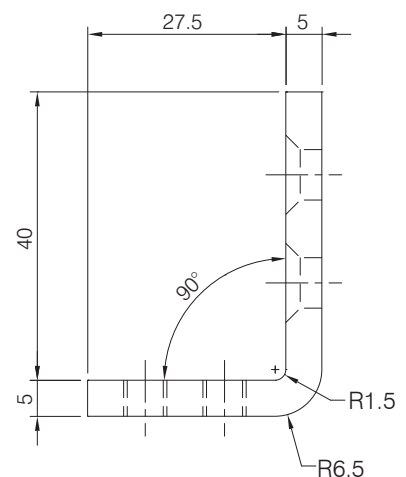
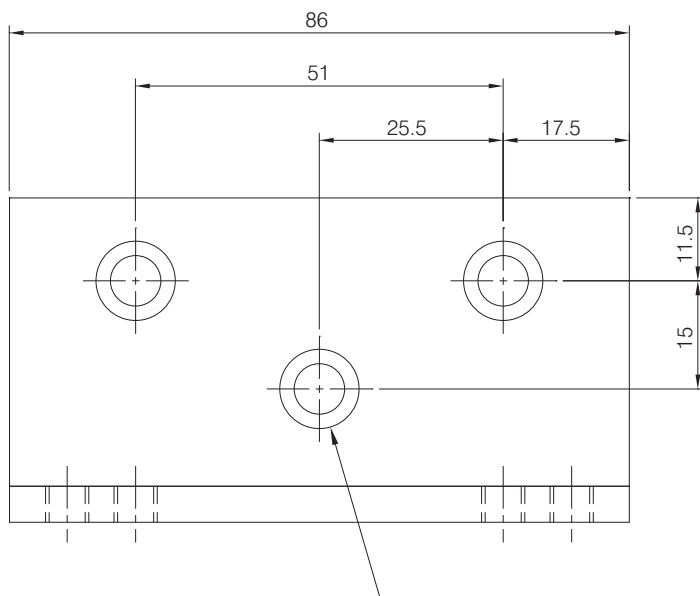

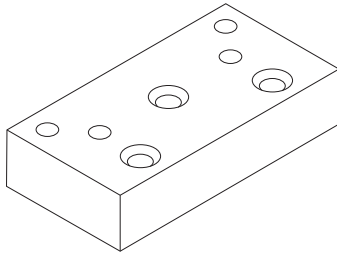

ISO view not to scale

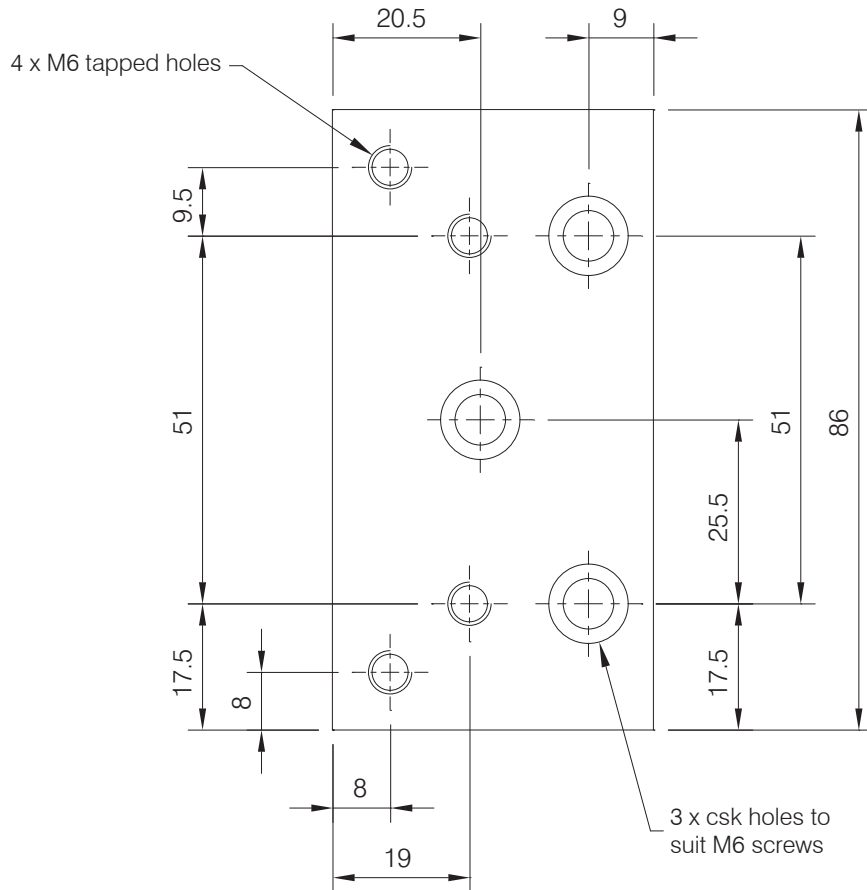
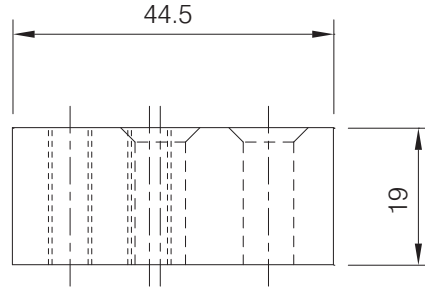

**Material:** Aluminium  
**Finish:** Mill finish



**THE PARKSIDE GROUP LTD**

THE WILLOW CENTRE  
17 WILLOW LANE, MITCHAM, SURREY, CR4 4NX  
Tel: 020-8685 9685 Fax: 020-8646 5096  
Email: axim@parksidegroup.co.uk  
Web Site: <http://www.axim.co.uk>

SCALE	NTS @A4
DATE	MARCH 2014
For scaled technical or CAD drawings, please contact AXIM.	

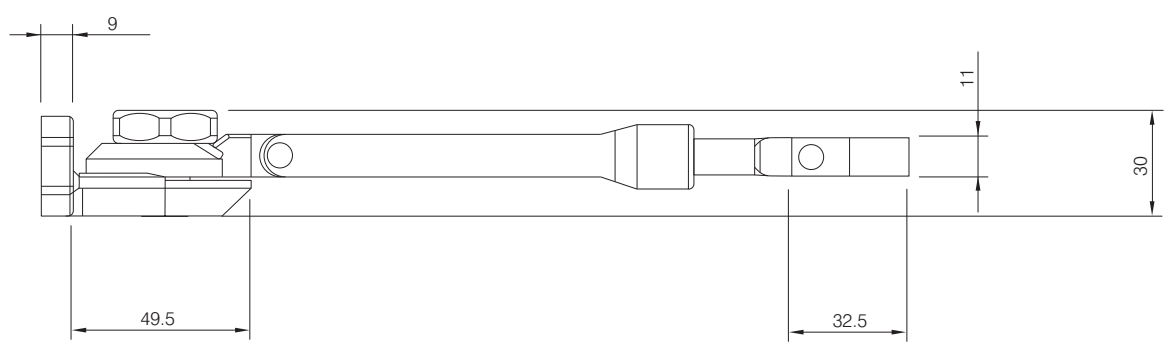
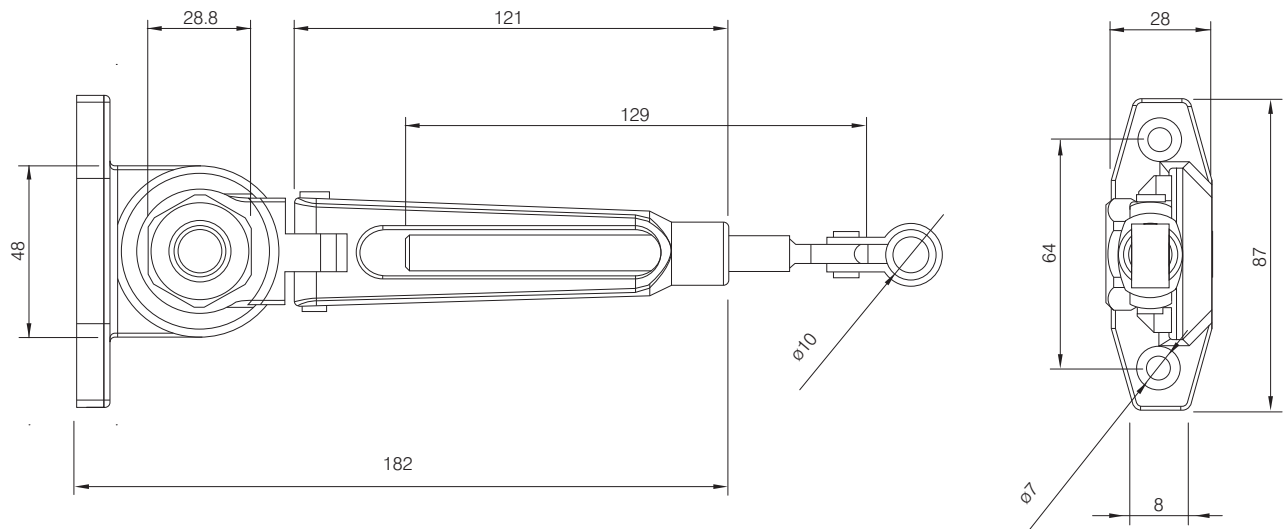

**THE PARKSIDE GROUP LTD**

THE WILLOW CENTRE  
17 WILLOW LANE, MITCHAM, SURREY, CR4 4NX  
Tel: 020-8685 9685 Fax: 020-8646 5096  
Email: axim@parksidegroup.co.uk  
Web Site: <http://www.axim.co.uk>

SCALE	NTS @A4
DATE	MARCH 2014

For scaled technical or CAD drawings,  
please contact AXIM.

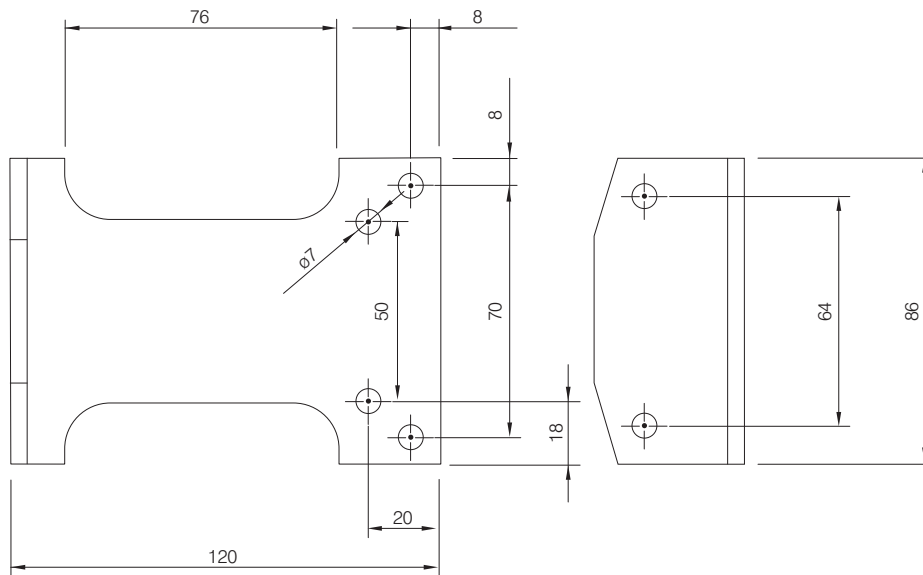
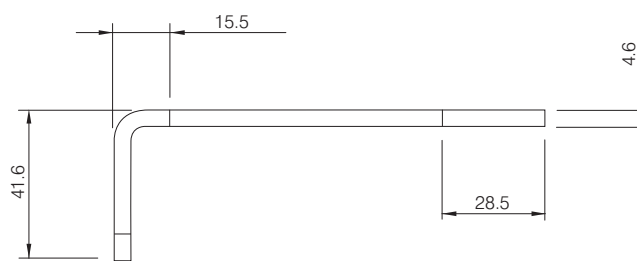
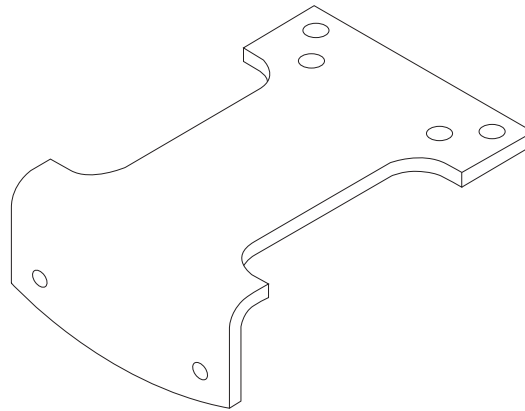

**THE PARKSIDE GROUP LTD**

THE WILLOW CENTRE  
 17 WILLOW LANE, MITCHAM, SURREY, CR4 4NX  
 Tel: 020-8685 9685 Fax: 020-8646 5096  
 Email: axim@parksidegroup.co.uk  
 Web Site: <http://www.axim.co.uk>

SCALE	NTS @A4
DATE	MARCH 2014
For scaled technical or CAD drawings, please contact AXIM.	



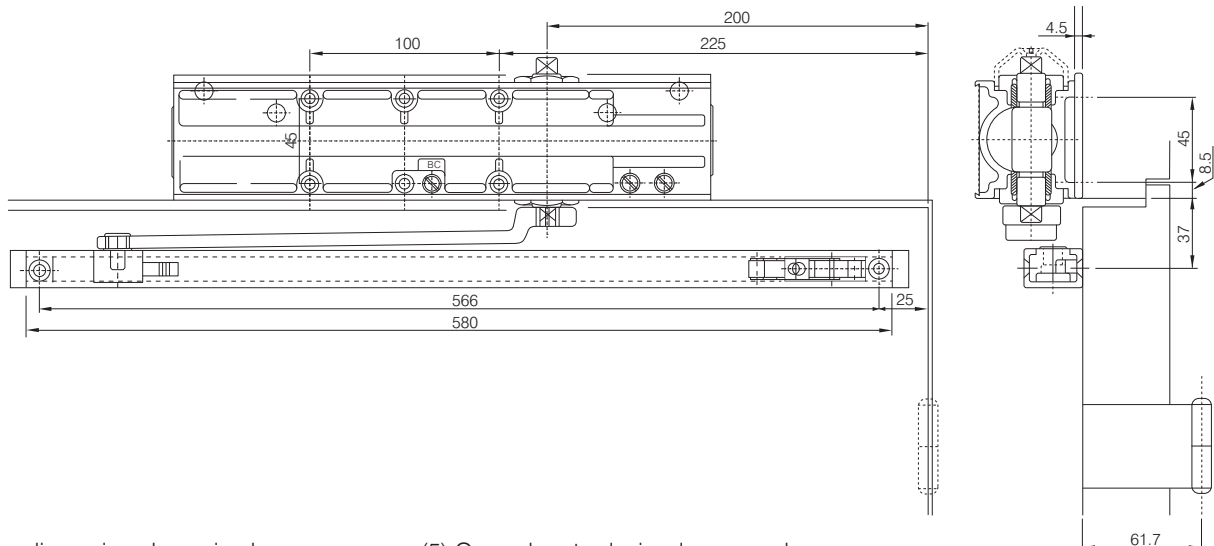
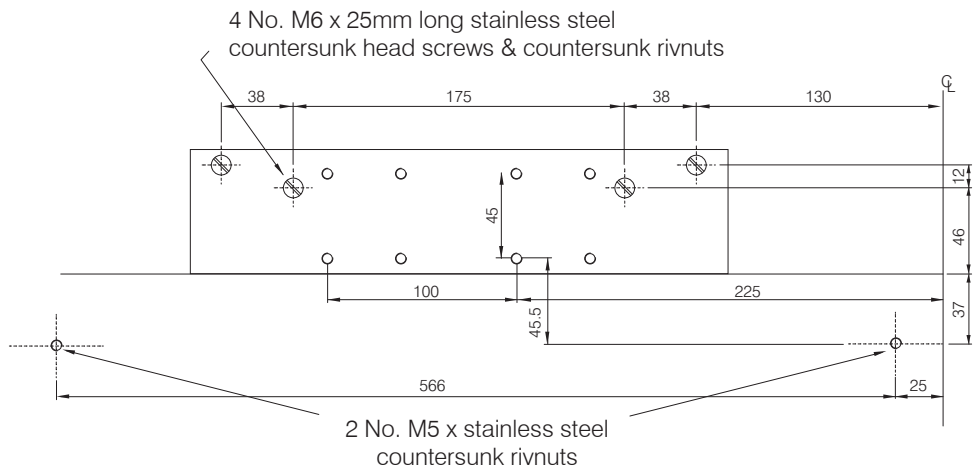

- (1) Use dimension shown in above template to mark six holes on door for door closer and two holes for sliding channel.
- (2) Drill holes in door for 4 - #10 wood screw or drill and tape for 4--M5 x 0.8 (10 x 24) machine screw.
- (3) Drill holes in frame for 2 - #10 wood screw or drill and tape for 2--M5 x 0.8 (10 x 24) machine screw.
- (4) Mount closer and sliding channel, place arm on shaft about 55° from parallel position (as drawing), force arm to parallel position and use ⑤ screw to attached arm & ④ sliding block.
- (5) Open door to desire degree and move the hold open device to be in touch with the sliding block. Tighten the ② adjustment screw.
- (6) For adjusting hold-open force, pls adjust the ③ nut -- clockwise for increasing force & counterclockwise for decreasing. (③ nut can't be adjusted over 2 turns.)

Note: If hold open function is not necessary, please don't install the 'hold open device' into channel.

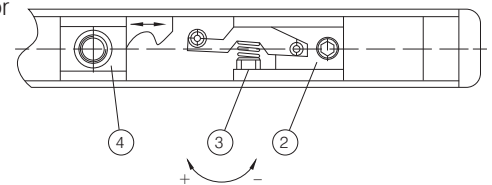

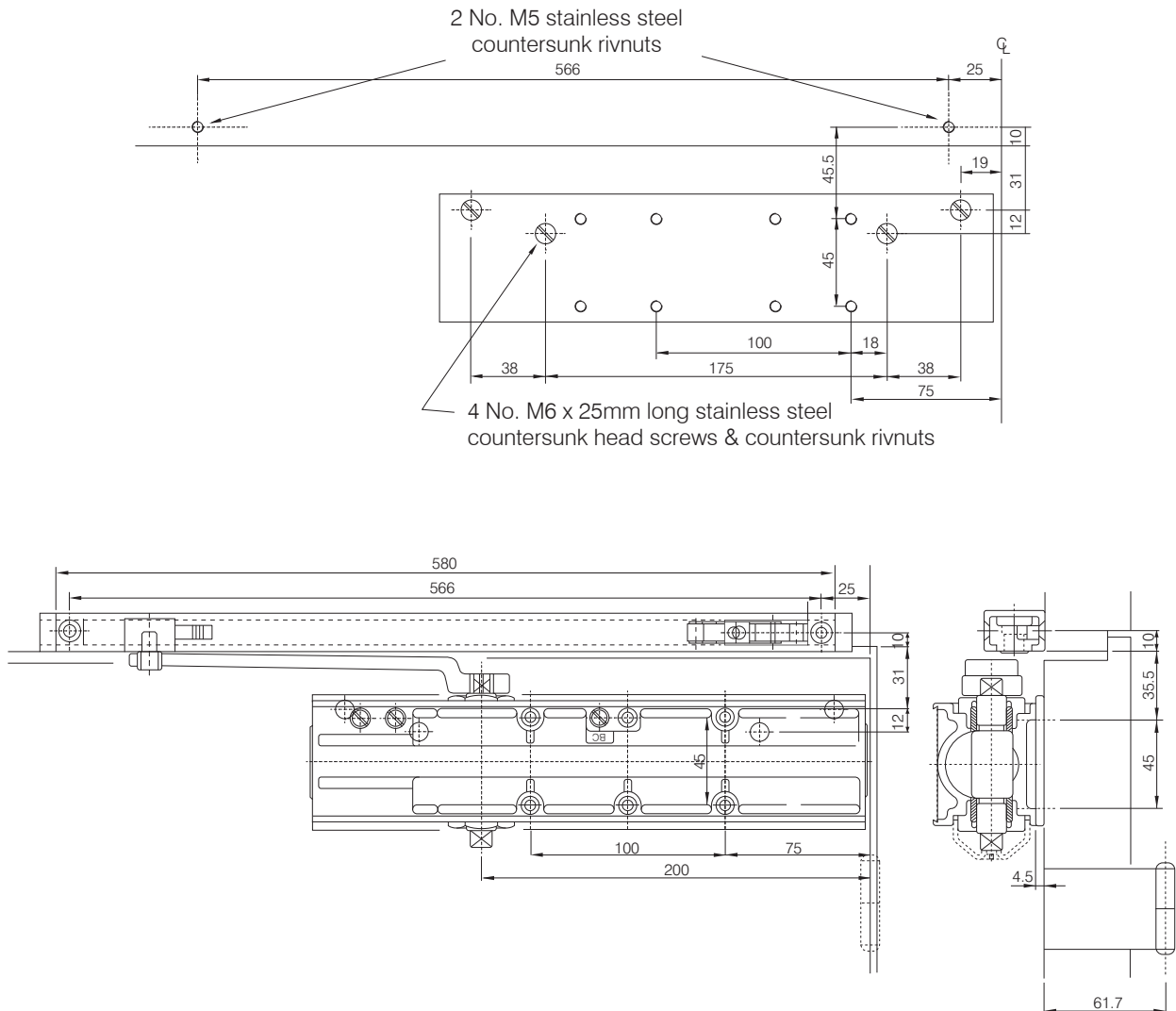

- (1) Use dimension shown in above template to mark six holes on door for door closer and two holes for sliding channel.
- (2) Drill holes in door for 4 - #10 wood screw or drill and tape for 4--M5 x 0.8 (10 x 24) machine screw.
- (3) Drill holes in frame for 2 - #10 wood screw or drill and tape for 2--M5 x 0.8 (10 x 24) machine screw.
- (4) Mount closer and sliding channel, place arm on shaft about 55° from parallel position (as drawing), force arm to parallel position and use ⑤ screw to attached arm & ④ sliding block.

- (5) Open door to desire degree and move the hold open device to be in touch with the sliding block. Tighten the ② adjustment screw.

- (6) For adjusting hold-open force, pls adjust the ③ nut -- clockwise for increasing force & counterclockwise for decreasing. (③ nut can't be adjusted over 2 turns.)

Note: If hold open function is not necessary, please don't install the 'hold open device' into channel.

