

ITEM	DESCRIPTION	SECTION
<b>Concealed Overhead Transom Closers</b>		
TC-8800 Series	Versatile Closer Technical Information	1:01
	Assembly Details	1:02 - 1:09
TC-9600 Series	Extended Spindle Closer Technical Information	1:10
TC-9900 Series	Universal Closer Technical Information	1:11 - 1:12
TC-8800/9600/9900 Series	Technical Support	1:13 - 1:15
<b>Floor Springs</b>		
FS-4000 Series	Versatile Floor Spring Technical Information	2:01
	Assembly Details	2:02 - 2:07
FS-6000 Series	Narrow Body Floor Spring Technical Information	2:08
	Assembly Details	2:09 - 2:11
FS-8500 Series	Compact Body Floor Spring Technical Information	2:12
	Assembly Details	2:13
FS-9500 Series	Installation and Adjustment	2:14 - 2:15
<b>Surface Closers</b>		
FC-1000 Series	Universal Closer Technical Information	3:01
	Assembly Details	3:02 - 3:06
FC-1500 Series	Multi-Strength Closer Technical Information	3:07
	Assembly Details	3:08 - 3:17
FC-3000 Series	Budget / Contract Closer Technical Information	3:18
	Assembly Details	3:19 - 3:27
<b>Panic Exit Device</b>		
PR-7085 Series	Concealed Rod Crash Bar Technical Information	4:01
	Assembly Details	4:02 - 4:08
PR-7085P Series	Concealed Rod Paddle Technical Information	4:09
	Assembly Details	4:10 - 4:14
PR-7095 Series	Rim Mounted Crash Bar Technical Information	4:15
	Assembly Details	4:16 - 4:20
PR-7095P Series	Rim Mounted Paddle Technical Information	4:21
	Assembly Details	4:22 - 4:25
PR-7100 Series	Concealed Rod Soft Touch Bar Technical Information	4:26
	Assembly Details	4:27 - 4:35
PR-7300 Series	Rim Mounted Soft Touch Bar Technical Information	4:36
	Assembly Details	4:37 - 4:42
PR-7000 Series	Technical Support	4:43
<b>Flush Bolt</b>		
FB-6200 Series	Flush Bolt 23mm Wide Technical Information	5:01 - 5:02
FB-6300 Series	Flush Bolt 25mm Wide Technical Information	5:03
FB-6400 Series	Flush Bolt 20mm Wide Technical Information	5:04
FB-6500 Series	Flush Bolt Cylinder Operated Technical Information	5:05 - 5:06
<b>Handles</b>		
HD-80 Series	Aluminium Tube Technical Information	6:01 - 6:02
HD-82 Series	Stainless Steel Tube Technical Information	6:03 - 6:04
HD-90 Series	Aluminium Pad Technical Information	6:05
HD-92 Series	Aluminium Pad Technical Information	6:06
HD-91 Series	Stainless Steel Pull Technical Information	6:07 - 6:14
HD-48 Series	Stainless Steel Flush Pull Technical Information	6:15
HD-Series	Stainless Steel Handle Maintenance Information	6:16
<b>Locks, Latches, Electric Strikes, Paddle and Lever Handles</b>		
LK-1800 Series	Hook Lock Technical Information	7:01 - 7:06
LK-2100 Series	Dead Latch Technical Information	7:07 - 7:15
ES-2100 Series	Electric Strike Technical Information	7:16 - 7:18
PH-2100 Series	Paddle Handle Technical Information	7:19
LK-2100-75/76	Rim Cylinder and Thumb Turn	7:20
<b>Letter Plates</b>		
LP-500 Series	Letter Plates Technical Information	8:01 - 8:03



DOOR WIDTH	CLOSER SIZE	CLOSING FORCE in Nm (kpm)	NO HOLD	HOLD OPEN 90°	HOLD OPEN 105°
			PRODUCT CODE		
Up to 750mm	1	20 (2.0)	8801-00*	8801-90*	8801-105
751 to 950mm	2	27 (2.7)	8802-00*	8802-90*	8802-105
951 to 1150mm	3	33 (3.3)	8803-00*	8803-90*	8803-105

SHIPPING WEIGHT 4:46KG

SELECT SIZE SMALLER FOR INTERNAL DOORS.  
SELECT SIZE LARGER FOR DOORS IN SEVERE CONDITIONS.  
\*5mm, 10mm and 15mm SPINDLE EXTENSION  
OPTIONS AVAILABLE.  
\*\* STANDARD SPINDLE SIZE

BODY UNIT AND FIXINGS	PRODUCT CODE
DUMMY BODY UNIT	TC-8800

APPLICATIONS  
Double or single action.  
Centre hung offset pivot with special arm.  
Side load and end fittings.  
65mm pivot point & 70mm pivot point.

**CLOSING ADJUSTMENT**

**MAXIMUM DOOR LEAF 100Kgs**

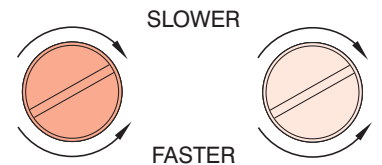
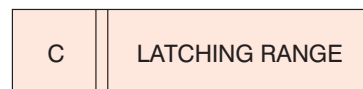
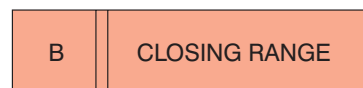
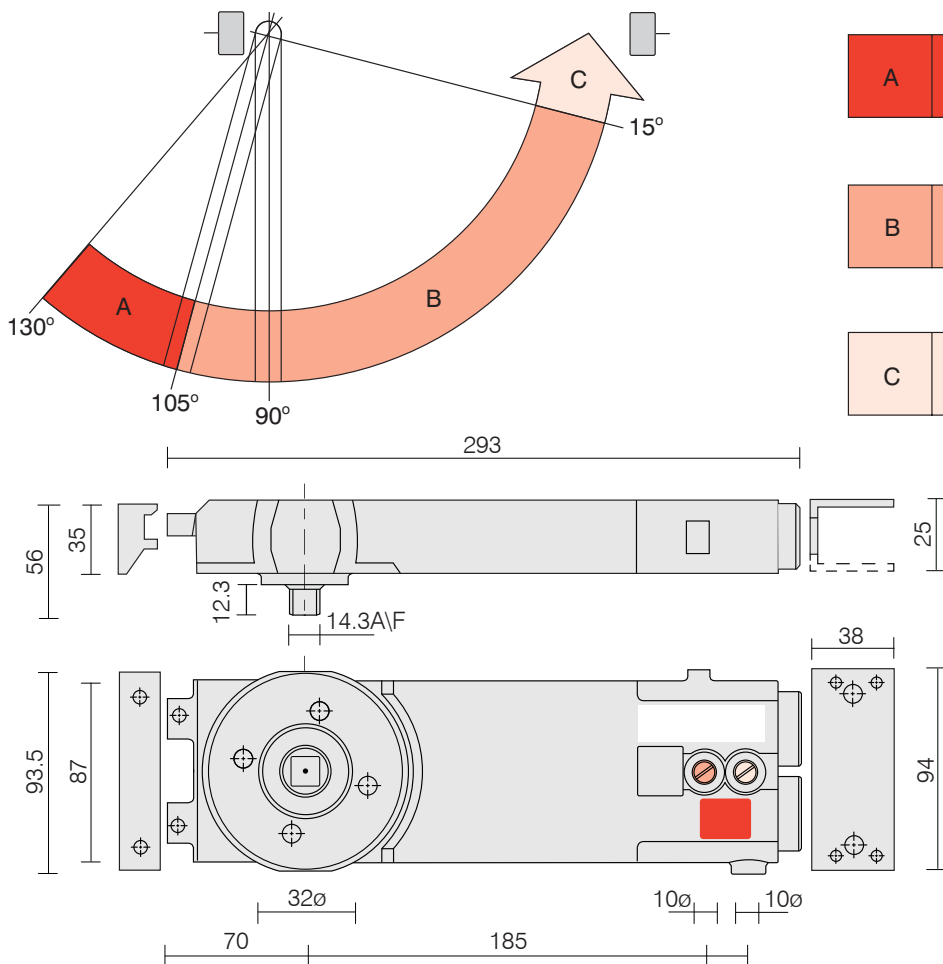

MAXIMUM TWO TURNS  
IN EITHER DIRECTION

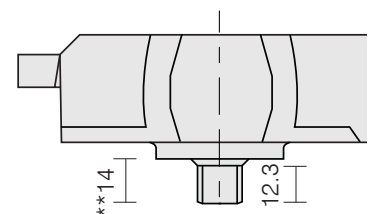

**GUARANTEE**

AXIM TRANSOM CLOSERS AND ACCESSORIES ARE GUARANTEED FOR 30 MONTHS FROM THE DATE OF MANUFACTURE AGAINST DEFECT IN MATERIAL AND WORKMANSHIP. THIS GUARANTEE IS VOID IF THE PRODUCT HAS BEEN INCORRECTLY INSTALLED OR DAMAGED IN USE. CLAIMS FOR DAMAGE INCURRED OR WORK DONE THEREON WILL NOT BE ACCEPTED.

AXIM RESERVE THE RIGHT TO UPDATE ITS PRODUCT INFORMATION WITHOUT PRIOR NOTICE



**The Parkside Group Ltd**

The Willow Centre  
17 Willow Lane, Mitcham, Surrey, CR4 4NX  
Tel: 020-8685 9685 Fax: 020-8646 5096  
Email: axim@parksidegroup.co.uk  
Web Site: www.axim.co.uk

SCALE	NTS @A4
DATE	JULY 2017
For scaled technical or CAD drawings, please contact AXIM.	

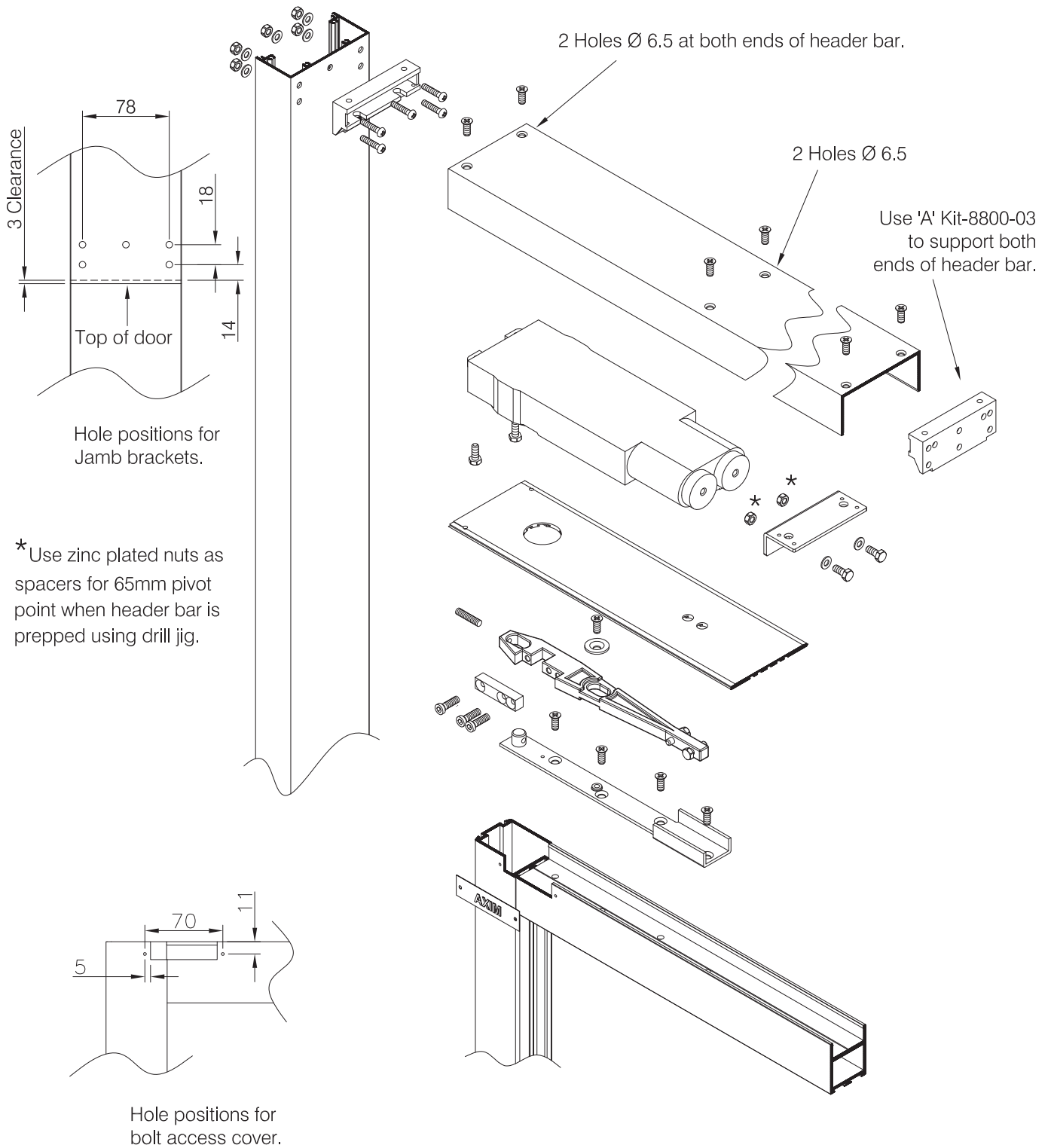

The Parkside Group Ltd

The Willow Centre  
17 Willow Lane, Mitcham, Surrey, CR4 4NX  
Tel: 020-8685 9685 Fax: 020-8646 5096  
Email: axim@parksidegroup.co.uk  
Web Site: www.axim.co.uk

SCALE NTS @A4

DATE AUGUST 2017

For scaled technical or CAD drawings,  
please contact AXIM.

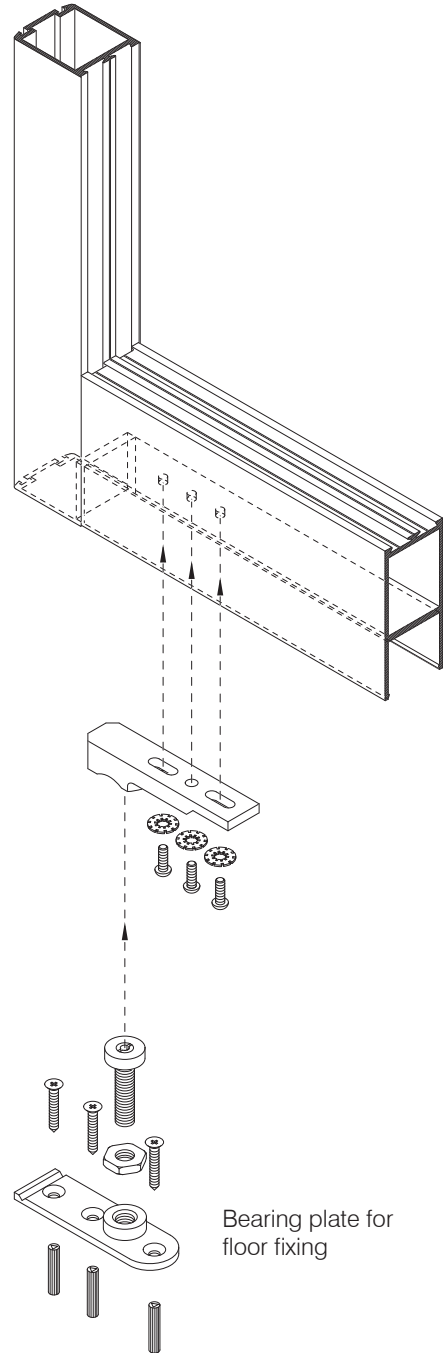
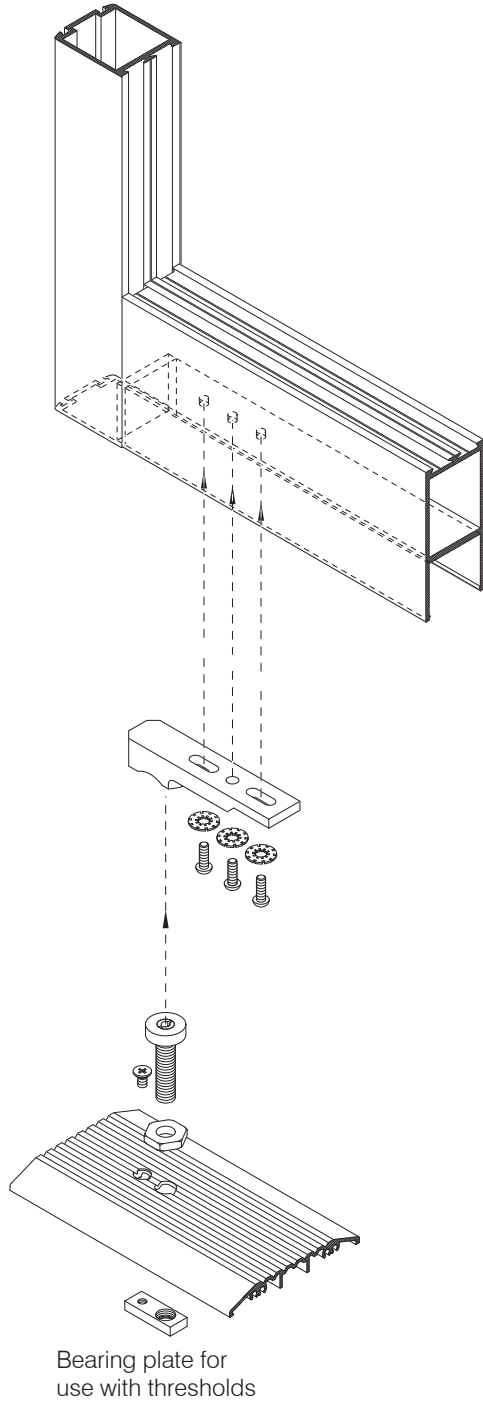

The Parkside Group Ltd

The Willow Centre  
17 Willow Lane, Mitcham, Surrey, CR4 4NX  
Tel: 020-8685 9685 Fax: 020-8646 5096  
Email: axim@parksidegroup.co.uk  
Web Site: www.axim.co.uk

SCALE NTS @A4

DATE MARCH 2014

For scaled technical or CAD drawings,  
please contact AXIM.

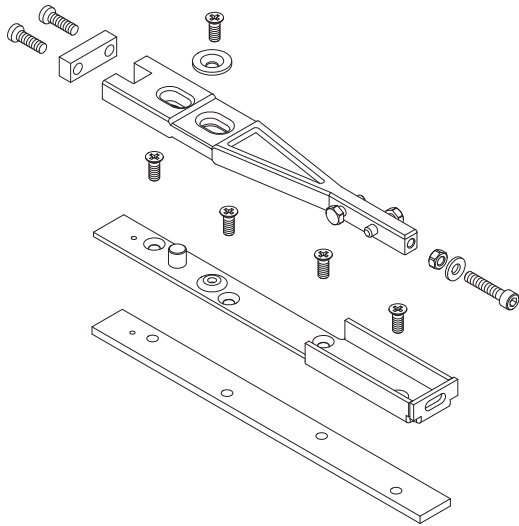

**End load top arm & spacer bar TC-8800-15**

For use on end loading and anti-finger trap doors.  
When using standard door rails spacer bar is not required.

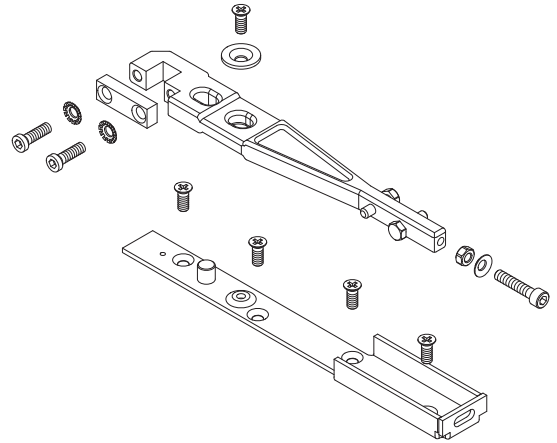
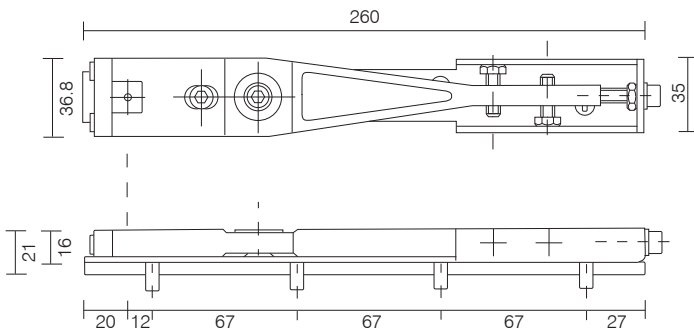

**Std. top side load arm TC-8800-13**

For use on side loading and anti-finger trap doors.

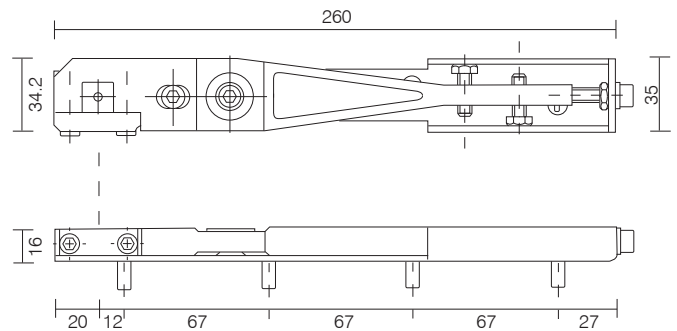

**The Parkside Group Ltd**

The Willow Centre  
17 Willow Lane, Mitcham, Surrey, CR4 4NX  
Tel: 020-8685 9685 Fax: 020-8646 5096  
Email: [axim@parksidegroup.co.uk](mailto:axim@parksidegroup.co.uk)  
Web Site: [www.axim.co.uk](http://www.axim.co.uk)

SCALE NTS @A4

DATE MARCH 2014

For scaled technical or CAD drawings,  
please contact AXIM.

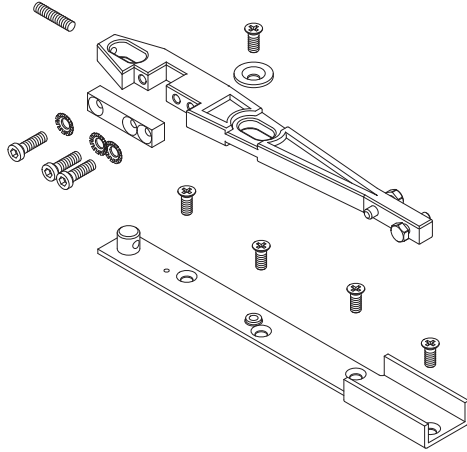

**Top side load arm TC-8800-T13**  
For use on side loading doors.  
(Arm supplied with standard transom closer kit)

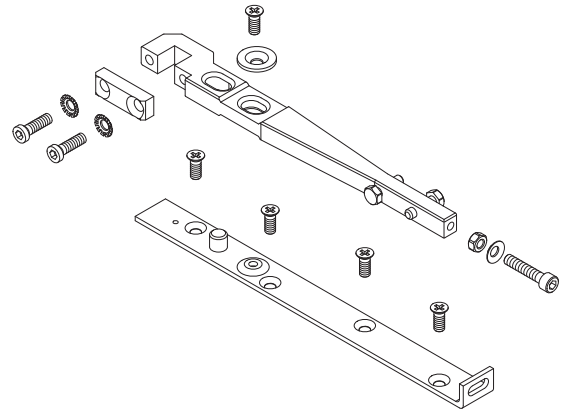
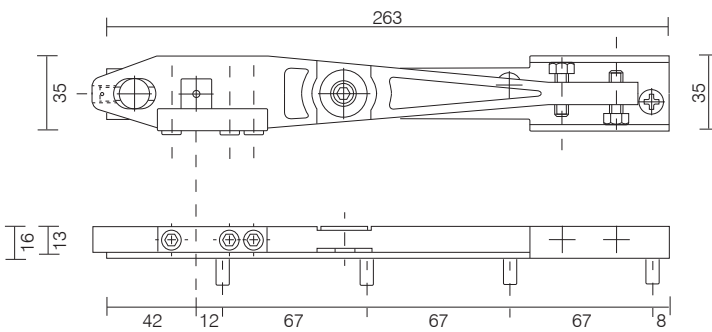

**Universal arm TC-8800-01**  
For use on side loading and armour glass doors

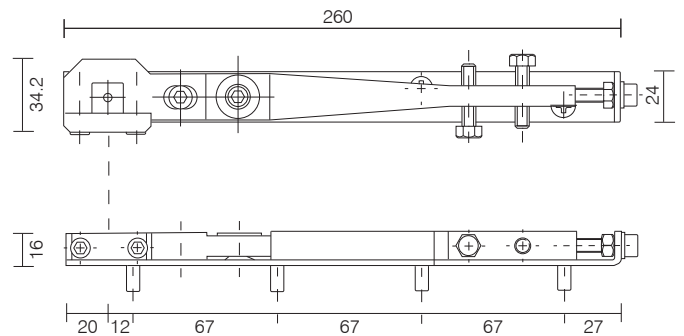

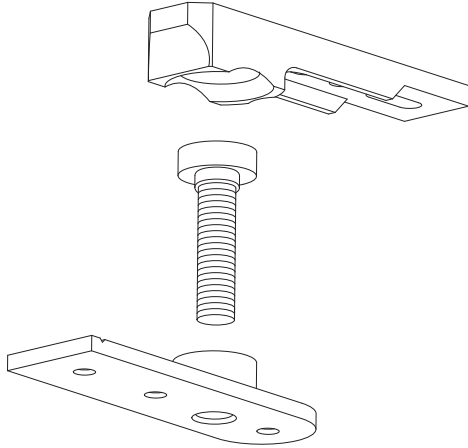

Std bottom pivot assembly  
**TC-8800-02**

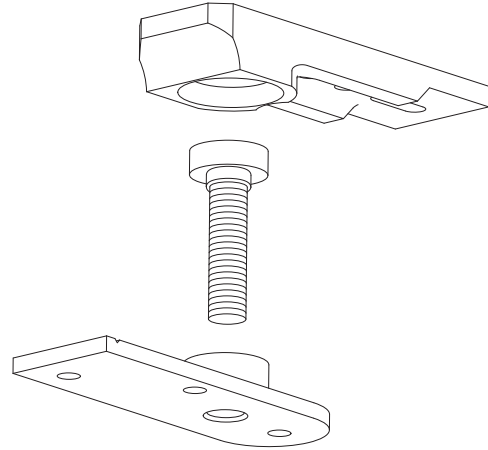

Heavy duty bottom pivot assembly  
**TC-9500-17**. Used with anti finger-trap doors

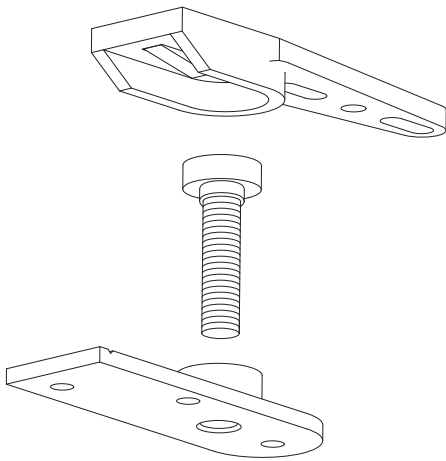

End load bottom pivot assembly  
**TC-8800-14**

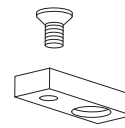

Alternative bottom bearing plate for use with  
thresholds supplied as standard with all bottom  
pivot assemblies



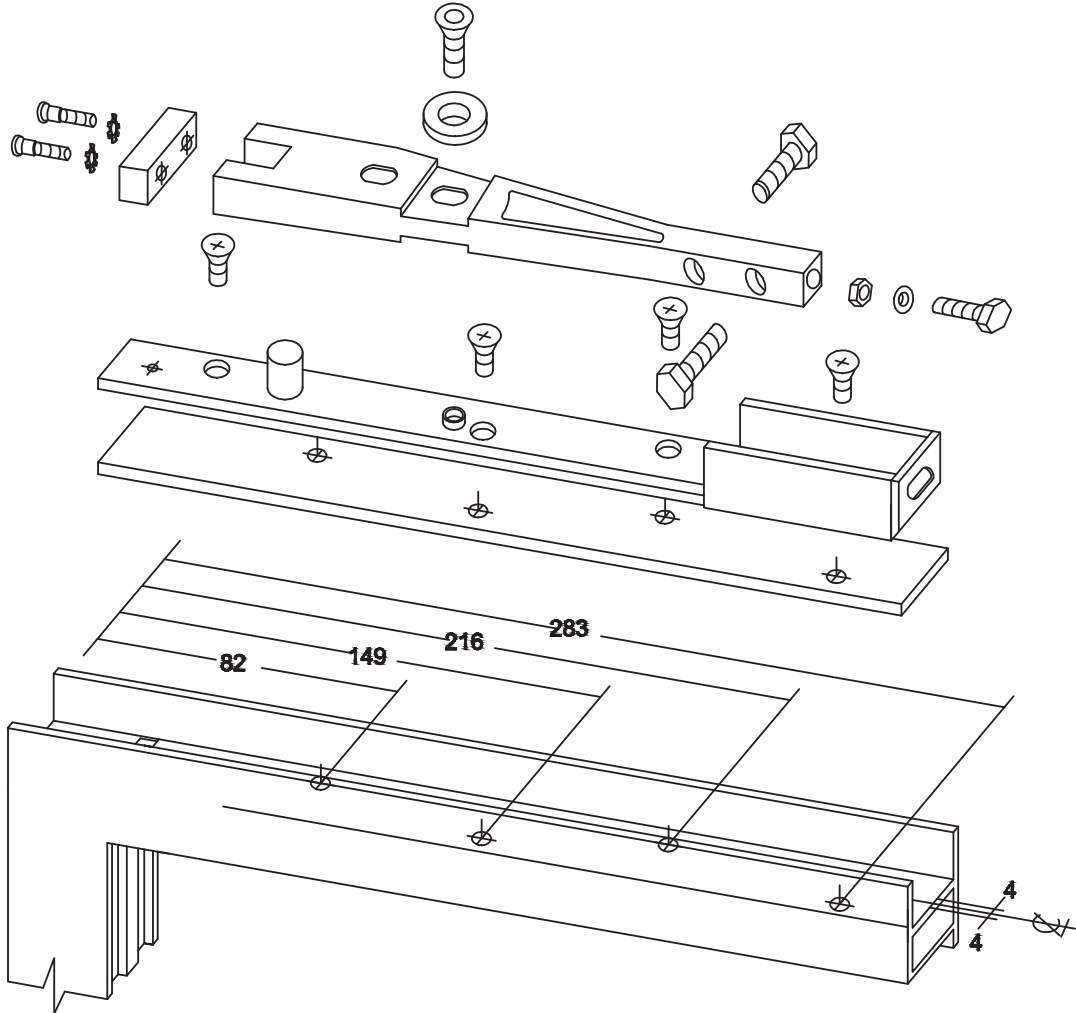

The Parkside Group Ltd

The Willow Centre  
17 Willow Lane, Mitcham, Surrey, CR4 4NX  
Tel: 020-8685 9685 Fax: 020-8646 5096  
Email: axim@parksidegroup.co.uk  
Web Site: www.axim.co.uk

SCALE NTS @A4

DATE JULY 2017

For scaled technical or CAD drawings,  
please contact AXIM.

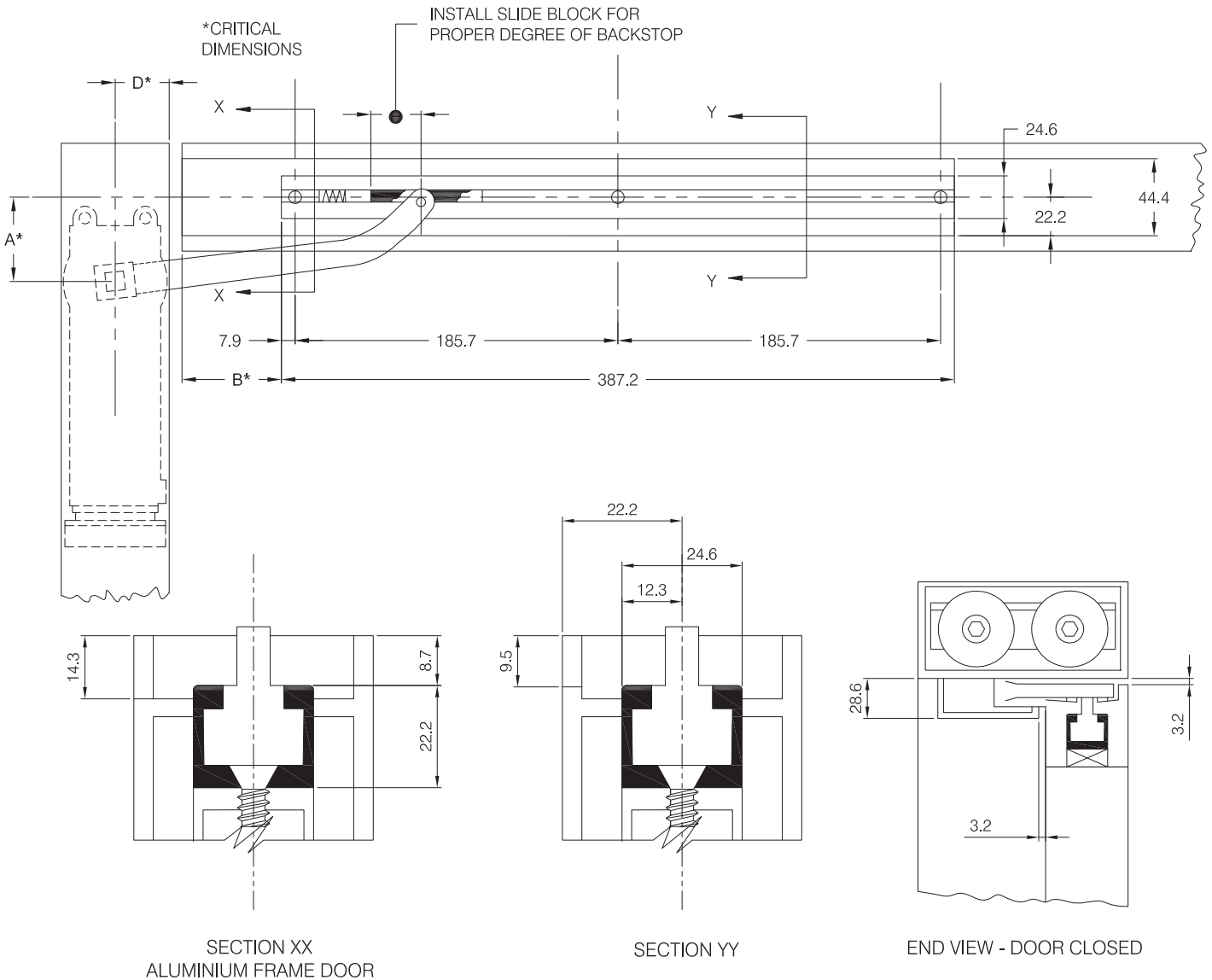

**DETERMINE HOW DOOR IS HUNG AND DEGREE OF CLOSER BACKSTOP AND USE APPLICABLE CHART**

**HEADER PREPARATION:**

1. DIMENSION 'A', face of jamb to centre line of spindle must be maintained.
2. DIMENSION 'D', pivot of hinge side of header to centre line of spindle must be maintained regardless of header width.
3. All spacers and/or anchors other than standard 'F' clip package by others.

**DOOR PREPARATION:**

1. Rout out top rail as shown, for side channel spacers as required by manufacturer.
2. Rout inside face of top rail as shown for arm.
3. Offset pivots or butts by others.

STANDARD BUTT HINGE DOOR MINIMUM 101.6mm HEADER					19.1mm OFFSET PIVOTED DOOR FLUSH DOOR MINIMUM 101.6mm HEADER					15.9 mm OFFSET PIVOTED DOOR 3.2mm RECESSED DOOR MINIMUM 114.3mm HEADER				
Backstop	A (mm)	B (mm)	C (mm)	D (mm)	Backstop	A (mm)	B (mm)	C (mm)	D (mm)	Backstop	A (mm)	B (mm)	C (mm)	D (mm)
105°	95.25	98.4	66.7	50.8	105°	114.3	119.1	85.7	50.8	105°	114.3	119.1	85.7	54.0
90°	73	103.2	44.5	50.8	90°	95.25	125.4	60.3	50.8	90°	95.25	125.4	60.3	54.0



The Parkside Group Ltd

The Willow Centre  
 17 Willow Lane, Mitcham, Surrey, CR4 4NX  
 Tel: 020-8685 9685 Fax: 020-8646 5096  
 Email: axim@parksidegroup.co.uk  
 Web Site: www.axim.co.uk

SCALE	NTS @A4
DATE	AUGUST 2017
For scaled technical or CAD drawings, please contact AXIM.	

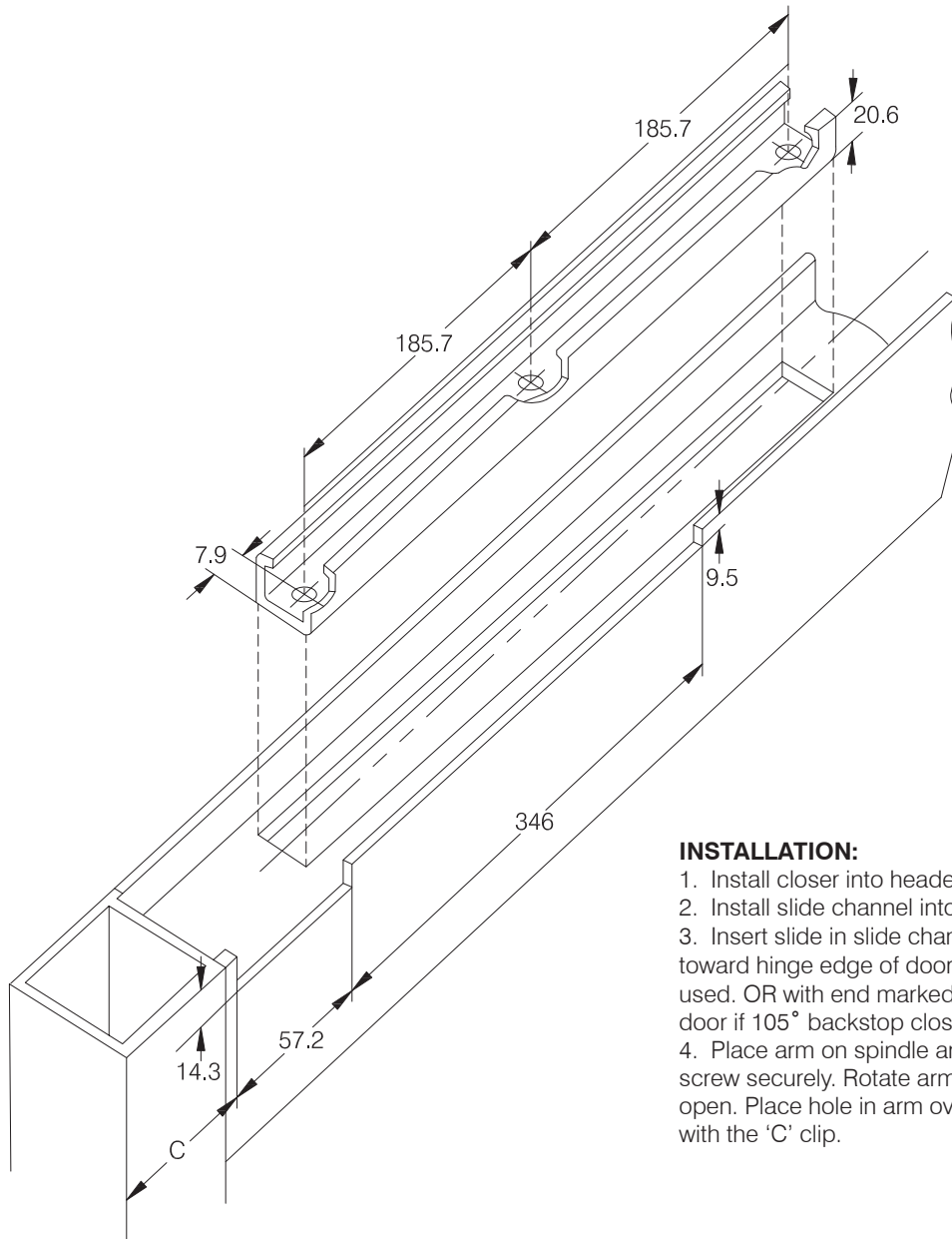

**INSTALLATION:**

1. Install closer into header.
2. Install slide channel into top rail.
3. Insert slide in slide channel with end marked 90° toward hinge edge of door if 90° backstop closer is used. OR with end marked 105° toward hinge edge of door if 105° backstop closer is used.
4. Place arm on spindle and tighten 1/4"-20 socket head screw securely. Rotate arm from centre as if door were open. Place hole in arm over pin in the slide and secure with the 'C' clip.

DOOR WIDTH	CLOSER SIZE	CLOSING FORCE in Nm (kpm)	NO HOLD	HOLD OPEN 90°
			PRODUCT CODE	
Up to 750mm	1	20 (2.0)	9601-00-E	9601-90-E
751 to 950mm	2	27 (2.7)	9602-00-E	9602-90-E
951 to 1150mm	3	33 (3.3)	9603-00-E	9603-90-E

SHIPPING WEIGHT 4:46KG

BODY UNIT AND FIXINGS	PRODUCT CODE
DUMMY BODY UNIT	TC-9600-E

SELECT SIZE SMALLER FOR INTERNAL DOORS.  
SELECT SIZE LARGER FOR DOORS IN SEVERE CONDITIONS.

APPLICATIONS  
Double or single action.  
Centre hung offset pivot with special arm.  
Side load and end fittings.  
70mm pivot point.

**CLOSING ADJUSTMENT**

**MAXIMUM DOOR LEAF 100Kgs**

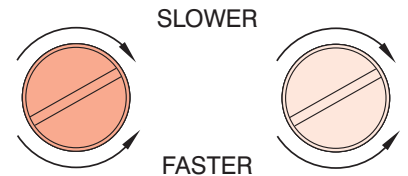
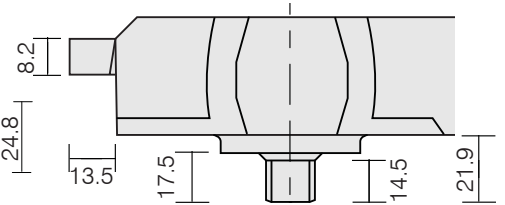
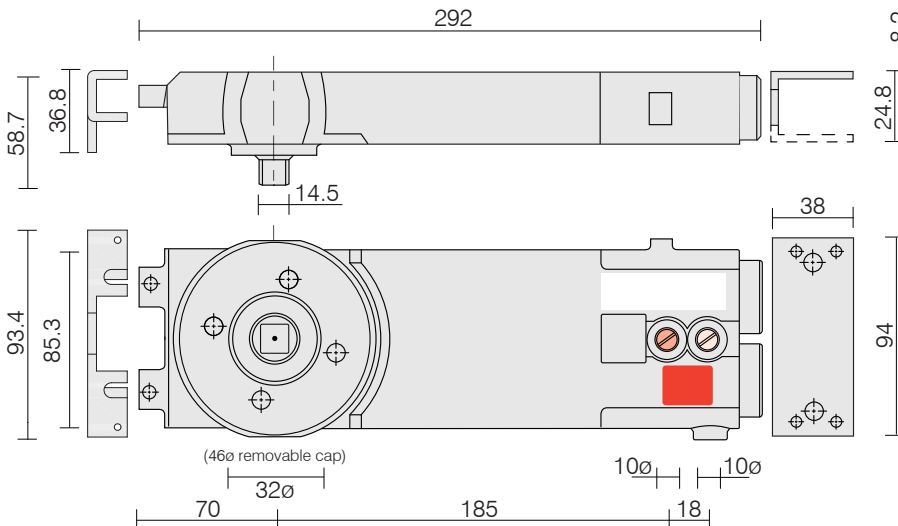
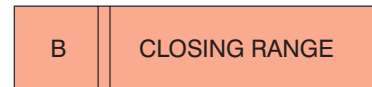
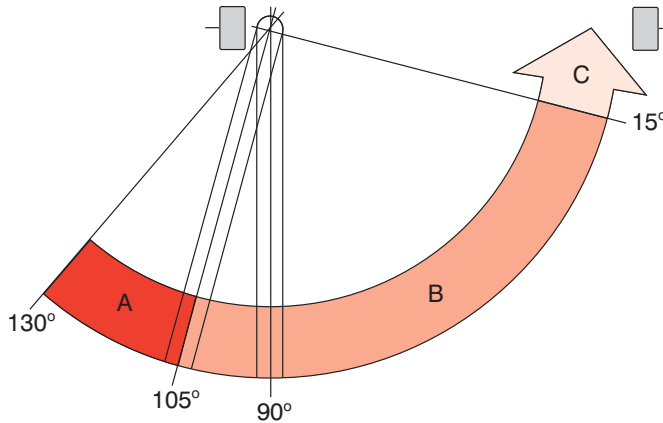

**MAXIMUM TWO TURNS**

**IN EITHER DIRECTION**

**GUARANTEE**

AXIM TRANSOM CLOSERS AND ACCESSORIES ARE GUARANTEED FOR 30 MONTHS FROM THE DATE OF MANUFACTURE AGAINST DEFECT IN MATERIAL AND WORKMANSHIP. THIS GUARANTEE IS VOID IF THE PRODUCT HAS BEEN INCORRECTLY INSTALLED OR DAMAGED IN USE. CLAIMS FOR DAMAGE INCURRED OR WORK DONE THEREON WILL NOT BE ACCEPTED.

AXIM RESERVE THE RIGHT TO UPDATE ITS PRODUCT INFORMATION WITHOUT PRIOR NOTICE



**The Parkside Group Ltd**

The Willow Centre  
17 Willow Lane, Mitcham, Surrey, CR4 4NX  
Tel: 020-8685 9685 Fax: 020-8646 5096  
Email: axim@parksidegroup.co.uk  
Web Site: www.axim.co.uk

SCALE	NTS @A4
DATE	AUGUST 2017

For scaled technical or CAD drawings, please contact AXIM.

The Axim 9900 series door closer has been developed to provide the market with a truly universal door closer. This closer will offer the answer for new installations and for door maintenance where other leading transom closers have failed and a replacement closer is necessary.

**MODEL SELECTION TABLE**

DOOR WIDTH	CLOSER SIZE	CLOSING FORCE in Nm	NO HOLD	HOLD OPEN 90°
			PRODUCT CODE	
Up to 750mm	1	20	9901-00	9901-90
751 to 950mm	2	27	9902-00	9902-90
951 to 1150mm	3	33	9903-00	9903-90

SHIPPING WEIGHT 4.5 kgs

SELECT A SIZE SMALLER FOR INTERNAL DOORS  
SELECT SIZE LARGER FOR DOORS IN SEVERE CONDITIONS

BODY UNIT AND FIXINGS	PRODUCT CODE
DUMMY BODY UNIT	TC-9900

**APPLICATIONS**

Double or single action.  
Centre hung or offset pivot with special arm.  
Side load and end load fittings.  
70mm pivot point

**REPLACEMENTS**

Will replace Axim 8800 series, Dorma, Peters Jackson, Newman, Tonks, Ryobi and other leading transom closers without costly modifications to door or frame.  
Universal fittings included.

**TECHNICAL INFORMATION**

Independent, fully adjustable closing and latching speed controls with captivated screws preventing accidental removal.

3 power sizes, suitable for doors up to 1150mm wide and 100 Kgs. in weight.

Mechanical backcheck protects doors and closer when opening past 105°.

Fitting instructions are supplied with each body unit with a separate sheet covering replacement procedures.

**GUARANTEE**

AXIM TRANSOM CLOSERS ARE GUARANTEED FOR 30 MONTHS FROM THE DATE OF MANUFACTURE AGAINST DEFECT IN MATERIAL AND WORKMANSHIP THIS GUARANTEE IS VOID IF THE PRODUCT HAS BEEN INCORRECTLY INSTALLED OR DAMAGED IN USE. CLAIMS FOR DAMAGE INCURRED OR WORK DONE THEREON WILL NOT BE ACCEPTED.

AXIM RESERVE THE RIGHT TO UPDATE THIS PRODUCT INFORMATION WITHOUT PRIOR NOTICE

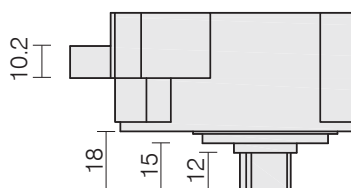

**CLOSING ADJUSTMENT**

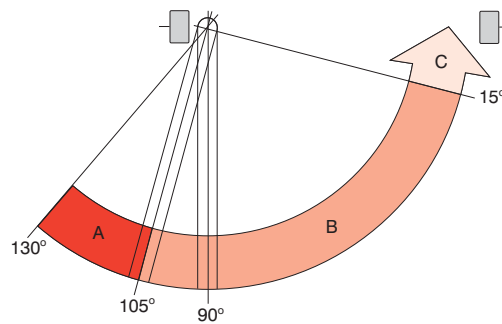

Independent valve screws permit closing speed adjustment from fully open to 15° and 15° to closed.

A	BACKCHECK
B	CLOSING RANGE
C	LATCHING RANGE

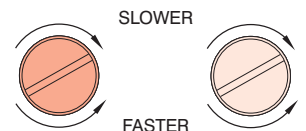

MAXIMUM TWO TURNS  
IN EITHER DIRECTION

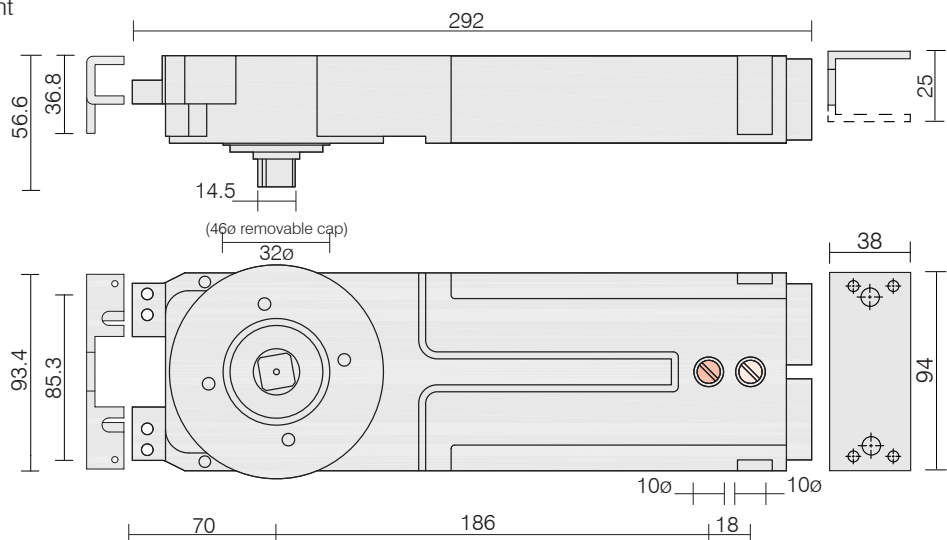

**The Parkside Group Ltd**

The Willow Centre  
17 Willow Lane, Mitcham, Surrey, CR4 4NX  
Tel: 020-8685 9685 Fax: 020-8646 5096  
Email: axim@parksidegroup.co.uk  
Web Site: www.axim.co.uk

SCALE	NTS @A4
DATE	AUGUST 2017
For scaled technical or CAD drawings, please contact AXIM.	



TITLE	<b>UNIVERSAL CONCEALED OVERHEAD TC-9900 SERIES ADJUSTABLE TRANSOM CLOSER</b>	SHEET No. <b>1:12</b>
SUB TITLE	<b>TECHNICAL INFORMATION</b>	

The Axim 9900 series door closer has been developed to provide the market with a truly universal door closer. This closer will offer the answer for new installations and for door maintenance where other leading transom closers have failed and a replacement closer is necessary.

**MODEL SELECTION TABLE**

DOOR WIDTH	CLOSER SIZE	CLOSING FORCE in Nm	NO HOLD	HOLD OPEN 90°
			PRODUCT CODE	
750mm - 1150mm	1-4	9-37	9900-ADJ-00	9900-ADJ-90
SHIPPING WEIGHT 4.5 kgs				

SELECT A SIZE SMALLER FOR INTERNAL DOORS  
SELECT SIZE LARGER FOR DOORS IN SEVERE CONDITIONS

**APPLICATIONS**

Double action.  
Centre hung.  
70mm pivot point.

**REPLACEMENTS**

Will replace Axim 8800 series, Dorma, Peters Jackson, Newman, Tonks, Ryobi and other leading transom closers without costly modifications to door or frame.  
Universal fittings included.

**TECHNICAL INFORMATION**

Independent, fully adjustable closing and latching speed controls with captivated screws preventing accidental removal.  
4 power sizes, suitable for doors up to 1150mm wide and 100 Kgs. in weight.

Fitting instructions are supplied with each body unit with a separate sheet covering replacement procedures.

BODY UNIT AND FIXINGS	PRODUCT CODE
DUMMY BODY UNIT	TC-9900
SAPCER BAR	TC-9900-03
CLOSER BRACKET SET	TC-9900-23

Independent valve screws permit closing speed adjustment from fully open to 15° and 15° to closed.

**CLOSING ADJUSTMENT**

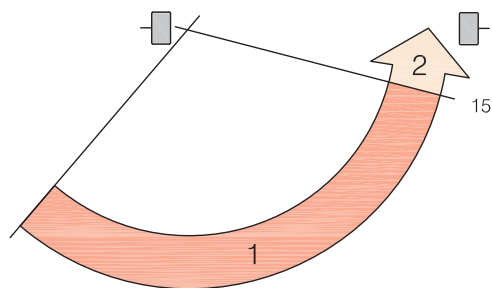

1 CLOSING RANGE

2 LATCHING RANGE

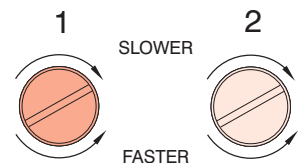

MAXIMUM TWO TURNS

IN EITHER DIRECTION

NUMBER OF TURNS	CLOSER SIZE			
	1	2	3	4
	+0	+2~+4	+5~+7	+8

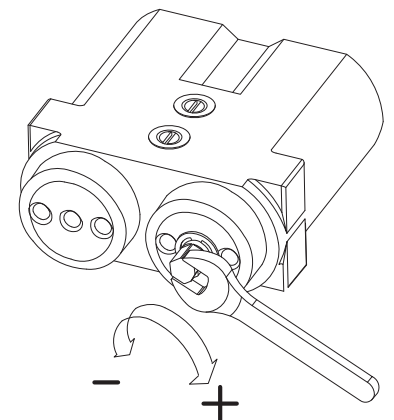
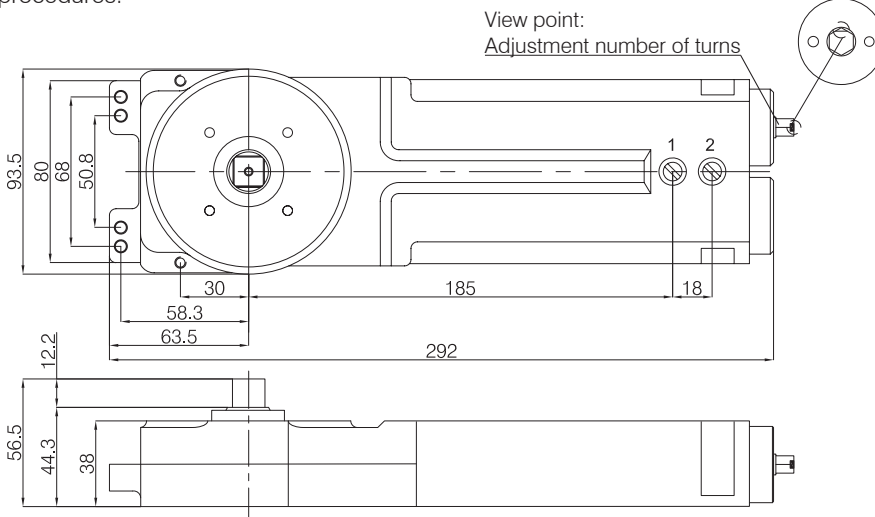

NOTE: Use 8mm open ended spanner supplied by others

**GUARANTEE**

AXIM TRANSOM CLOSERS ARE GUARANTEED FOR 30 MONTHS FROM THE DATE OF MANUFACTURE AGAINST DEFECT IN MATERIAL AND WORKMANSHIP. THIS GUARANTEE IS VOID IF THE PRODUCT HAS BEEN INCORRECTLY INSTALLED OR DAMAGED IN USE. CLAIMS FOR DAMAGE INCURRED OR WORK DONE THEREON WILL NOT BE ACCEPTED.

AXIM RESERVE THE RIGHT TO UPDATE THIS PRODUCT INFORMATION WITHOUT PRIOR NOTICE



**The Parkside Group Ltd**

The Willow Centre  
17 Willow Lane, Mitcham, Surrey, CR4 4NX  
Tel: 020-8685 9685 Fax: 020-8646 5096  
Email: axim@parksidegroup.co.uk  
Web Site: www.axim.co.uk

SCALE	NTS @A4
DATE	JULY 2017
For scaled technical or CAD drawings, please contact AXIM.	

**Introduction**

Axim door closers and accessories are guaranteed for a period of 30 months from the date of manufacture against defect in material and workmanship. The guarantee is void if the product has been incorrectly installed or damaged in use. The following notes on maintenance should ensure the closer will operate trouble free for many years.

The set of door controls comprises three main items. Firstly, a sealed unit 'the closer body' which is fitted inside the transom bar above the door and concealed with a removable cover plate. Secondly, a steel drive arm with a steel fixing channel fitted inside the top rail of the door 'the drive arm' which may be side or end loading. Finally the door is supported by a 'bottom pivot assembly'. This consists of a shoe fitted to the underside of the door and a pivot bolt, either fitted to a floor-fixed plate or directly fixed to an aluminium threshold.

**Closer body**

Broadly speaking there are six different closer options with the same external appearance. Closers are fitted with different size internal springs to give light, medium or heavy closing forces. Depending on varying factors such as weather conditions and width and height of the door the correct strength closer should be selected. Closers are also specified 'retention' or 'non-retention'. The former, sometimes referred to as hold-open, hold the door open at 90 degrees whilst the latter, sometimes named no hold-open, will return the door to a closed position regardless of the angle at which it is released. It is important not to wedge the door open as the wedge or stop will oppose the door closer and in time will twist the door.

It is important to realise closers can not be altered in the field and if necessary the closer would require exchanging for an alternative option.

Doors using this type of door closer are generally centre hung and double acting, i.e the door will open in and out unless prevented from doing so by an applied stop. Door closers will open to 130°. Door stops should be fitted to prevent the door striking the jamb or opening past this angle, as damage could occur to the door, frame, and/or closer.

**Removing the door**

Should it be necessary to change the door closer, this is not a difficult job and should take no more than an hour. Tools required:- Small and medium sized pozi head screwdrivers, 4mm and 5mm allen keys and a 10mm open-ended spanner.

Remove the name plate from the internal face of the door to expose the clamp block and fixings. Using an allen key remove the socket head bolts and special lock washers and put to one side. With someone to steady the door from outside, push the door away from the closer spindle, the door may require tapping gently with a soft faced mallet. Once the door is released from the spindle the door can be lifted off the bottom pivot.

Stack the door in a safe place. Remove the M4 screws from the cover plate and prise the cover plate free. The closer body is now visible and reference marks should be noted.

Stamping on the end of the spindle should read N.H.O or H.O.90 referring to the retention option. A number on the circular cover cap will relate to spring power size. A date stamp on the closer body, 96-12 for example will determine if the closer is within the warranty period. If the closer is faulty and still under guarantee please contact your supplier before undertaking any further work.

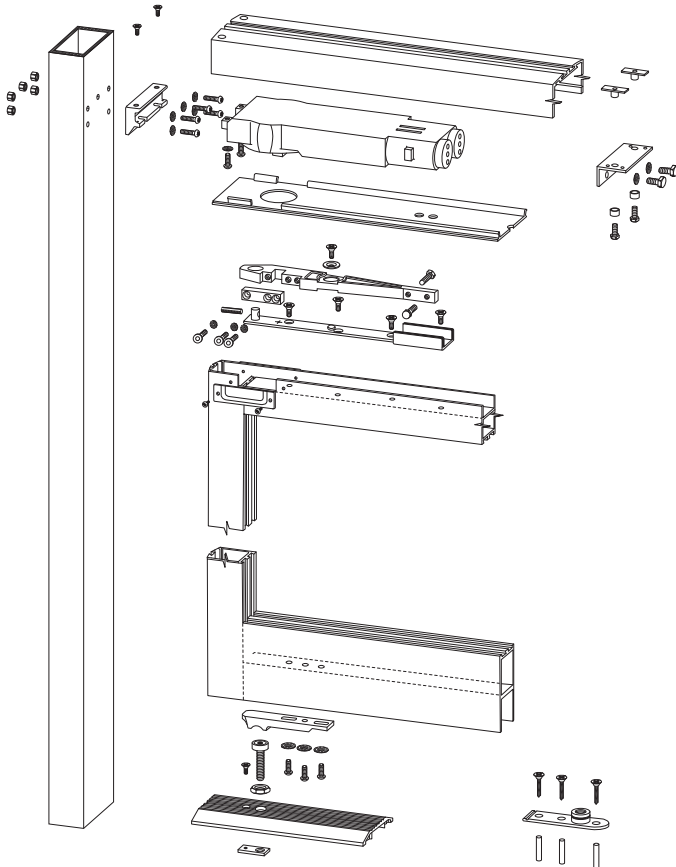

**The Parkside Group Ltd**

The Willow Centre  
17 Willow Lane, Mitcham, Surrey, CR4 4NX  
Tel: 020-8685 9685 Fax: 020-8646 5096  
Email: axim@parksidegroup.co.uk  
Web Site: www.axim.co.uk

SCALE	NTS @A4
DATE	MARCH 2014
For scaled technical or CAD drawings, please contact AXIM.	

**Changing the closer unit**

With a screwdriver loosen the two round head pozi screws connecting the closer to the jamb bracket.

Support the closer and remove the two hexagon head bolts and washers. The closer can now be lowered and removed. Take care not to drop it, the closer weighs 4 Kgs. (8.8lbs.)

Whilst the closer is removed check the fixings in the jamb bracket and tighten securely if loose. Check the steel angle bracket is secure within the header bar. Examine the pivot bearing in the threshold or floor plate, the bearing should be able to rotate freely and the 1/2" bolt should be secure.

To replace the closer reverse the removal procedure and ensure the clamp block screws and lock washers are very tight. If door adjustment is required refer to the section ALIGNMENT.

**Fault diagnosis**

**The following notes should enable a competent maintenance manager to rectify any problems that might occur. If in any doubt please contact the manufacturer as the wrong action could invalidate the warranty.**

**1) The door does not centre firmly but swings freely perhaps for a centimetre either side of the closer position. This is usually due to the clamp block not being fully tightened.**

Remove the small aluminium name plate from the door to expose the clamp block and screws. With an allen key wind in the two or three screws, depending on the arm type, very tightly. Refit the name plate.

**2) The door does not centre firmly as in item 1) and has even more free play.**

It is possible the clamp block has been too loose for too long and the closer spindle has worn if this is the case carry out the remedy as in item 1). If the problem persists the closer and/or top drive arm in the door will need replacing. Note this is not a fault of the closer or accessories but is due to indifferent installation.

**3) The door comes to rest firmly but is up to 25mm off centre.**

Procure a step ladder, or other means, enabling you to look down on to the top rail of the door. Loosen the hold-down, countersunk screw, securing the top arm, with an allen key. Adjust the hexagon bolts against the sides of the steel channel until the door centres in the correct position. Tighten the hold-down screw and check other fixings.

**4) The door drags on the floor/threshold or rubs on the underside of the transom.**

Procure a step ladder, or other means, enabling you to look down on to the top rail of the door. Loosen the hold-down, countersunk screw, securing the top arm, with an allen key and loosen off the hexagon bolts slightly.

a) Standard top arm type:

With the door open use a flat bladed screwdriver to turn the screw clockwise, lifting the door or anticlockwise lowering the door.

b) End load arm or special side loading:

Loosen the locknut against the upstand of the channel and turn the socket head screw with an allen key, clockwise, lifting the door or anticlockwise lowering the door. Tighten the hold-down screw and check other fixings.

**5) The door moves loosely off centre apparently out of control.**

The closer has been forced and strained for some reason and the internal parts have been damaged. The closer will need replacing.

**6) Oil leaking.**

Before despatch each closer is subjected to stringent tests to ensure against leaking. If oil appears to be leaking from the closer try to pin point the source. If leaking from around the spindle the seal may be damaged. If leaking from around one of the valve screws the same could apply. Providing the closer is within the warranty period and has not been subjected to misuse it will be replaced.



**The Parkside Group Ltd**

The Willow Centre  
17 Willow Lane, Mitcham, Surrey, CR4 4NX  
Tel: 020-8685 9685 Fax: 020-8646 5096  
Email: axim@parksidegroup.co.uk  
Web Site: www.axim.co.uk

SCALE	NTS @A4
DATE	MARCH 2014
For scaled technical or CAD drawings, please contact AXIM.	





TITLE	<b>CONCEALED OVERHEAD TRANSOM CLOSERS</b>	SHEET No. <b>1:15</b>
SUB TITLE	<b>TECHNICAL SUPPORT</b>	

### Six monthly maintenance

Detach the door as previously described, remove the coverplate and expose the closer. Tighten all fixing screws and bolts. Inspect the floor bearing and wipe away any debris, check the bearing rotates freely and the bolt is secured firmly in the plate or threshold. Lubricate with grease if necessary. Tighten all fixings, including the three screws to the bottom rail of the door securing the pivot shoe. Replace the coverplate and remount the door. Tighten all the top arm fixings, particularly the clamp block screws and centre locking screw. Replace the name plate and clean down the door as per finishers recommendations.

### Closing speed adjustment

Providing the closing and final latching speeds of the door closer have been correctly set on installation it should not be necessary to readjust at a later date. However, after the door closer has completed a short settling in period, minor adjustments may be required. It should be noted that inexperienced tampering with the valve screws would cause irreparable damage. The following notes will enable the operator to make simple adjustments – if in any doubt please seek advise from the manufacturer.

It is important to realise that the two valve screws will adjust the closing and latching speeds of the door closer, they will not adjust the closing or opening forces in any way. It is very likely the door closer will require only very minor adjustment, perhaps only one half turn of the valve screw. After any adjustment the door closing speed should be checked twice, by opening the door fully and allowing it to close, before proceeding.

Care must be taken not to unscrew the valve head beyond the level of the closer body when increasing the closing speed. Turning the valve past this limit will allow oil to escape and the closer will need to be replaced. On the other hand if the valve is turned clockwise, decreasing the closing speed, adjustment must cease when resistance is felt as will be damaged along with the oil seal if excessive force is used.



## The Parkside Group Ltd

The Willow Centre  
17 Willow Lane, Mitcham, Surrey, CR4 4NX  
Tel: 020-8685 9685 Fax: 020-8646 5096  
Email: [axim@parksidegroup.co.uk](mailto:axim@parksidegroup.co.uk)  
Web Site: [www.axim.co.uk](http://www.axim.co.uk)

SCALE	NTS @A4
DATE	MARCH 2014
For scaled technical or CAD drawings, please contact AXIM.	



**UNIVERSAL APPLICATION**

Suitable for left hand, right hand, single and double action doors.  
No hold and 90° hold open options.  
105° hold open available on special order.  
Medium strength spring for 100kg doors up to 1200mm wide. Light spring for 100kg doors up to 914mm wide.

**DOOR CONTROL**

Two separate valve screws control the closing and latching speeds independently. The closing action starts with the door fully open and ends at 15° from the closed position. At this point the latching valve takes over, thus allowing the door to close at the desired speed.

**BACKCHECK**

130° backcheck prevents damage to doors in windy conditions or where the door swing is limited to 90°.

**FULLY ADJUSTABLE**

The FS4000 floor spring is positionally adjustable for height, width, length and diagonally within the zinc plated cement box.

**SPINDLES**

\* Please specify the type of spindle required. 4000-NS model available without fitted spindle and will accept our range of spindle inserts.  
Extended spindles available for varying height requirements.  
Spindles stocked to suit a wide range of fittings from other manufacturers.

**ACCESSORIES**

Double action door straps, forged steel and zinc plated, for square or flat rectangular spindles.  
Product codes FS-4000-13S (Square), FS-4000-13F (Flat).  
Retractable top centre, die cast aluminium.  
Door part with adjustable bronze bearing complete with fixings.  
Two finishes available:  
Silver, Product Code FS-4000-0114.  
Bronze, Product Code FS-4000-0214.

**ADDITIONAL CEMENT BOX**

Product Code FS-4000-15.

**SPECIAL ORDER OPTIONS**

Hold open 85°, 105°, and 120°.  
Light spring 15Nm (for narrow width and light doors).

**COVER PLATES**

160mm x 328mm cover plates in three finishes.  
Stainless steel, Product code FS-4000-01.  
Bronze (B.M.A) Product code FS-4000-02.  
Polished brass Product code FS-4000-03.

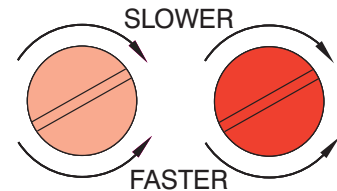
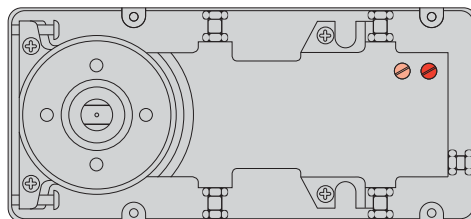
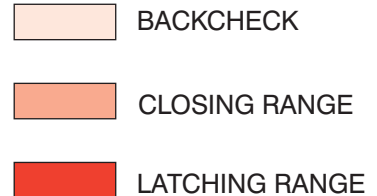
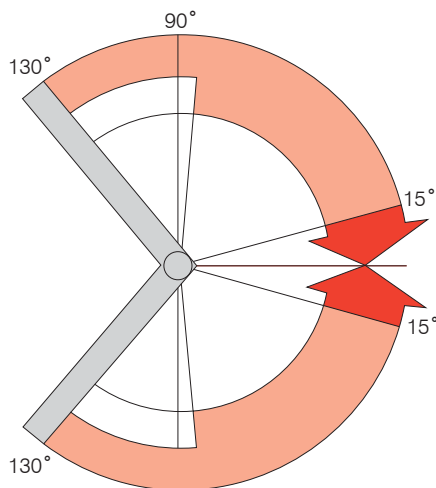

DOOR WIDTH in mm	SPRING STRENGTH	CLOSING FORCE in Nm (Kpm)	NO HOLD OPEN	HOLD OPEN 90°
			PRODUCT CODES	
915-1200 Up to 914	Medium Light	28 (2.8) 18 (1.8)	4002-00-NS	4002-90-NS
			4001-00-NS	4001-90-NS

**RETRACTABLE TOP CENTRE  
FS-4000-0114 SVR**

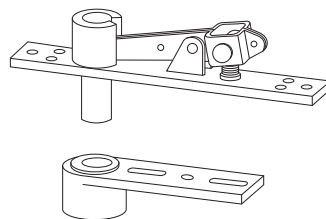

**DOOR STRAP FOR SQUARE SPINDLE  
FS-4000-13S**

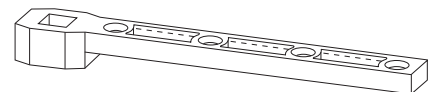

**DOOR STRAP FOR FLAT  
RECTANGULAR SPINDLE FS-4000-13F**

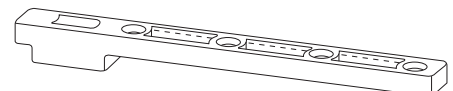

**GUARANTEE**

AXIM FLOOR SPRINGS ARE GUARANTEED FOR 30 MONTHS FROM THE DATE OF MANUFACTURE AGAINST DEFECT IN MATERIAL AND WORKMANSHIP. THIS GUARANTEE IS VOID IF THE PRODUCT HAS BEEN INCORRECTLY INSTALLED OR DAMAGED IN USE. CLAIMS FOR DAMAGE INCURRED OR WORK DONE THEREON WILL NOT BE ACCEPTED.

AXIM RESERVE THE RIGHT TO UPDATE ITS PRODUCT SPECIFICATIONS WITHOUT PRIOR NOTICE.



**The Parkside Group Ltd**

The Willow Centre  
17 Willow Lane, Mitcham, Surrey, CR4 4NX  
Tel: 020-8685 9685 Fax: 020-8646 5096  
Email: axim@parksidegroup.co.uk  
Web Site: www.axim.co.uk

SCALE	NTS @A4
DATE	JULY 2017

For scaled technical or CAD drawings, please contact AXIM.

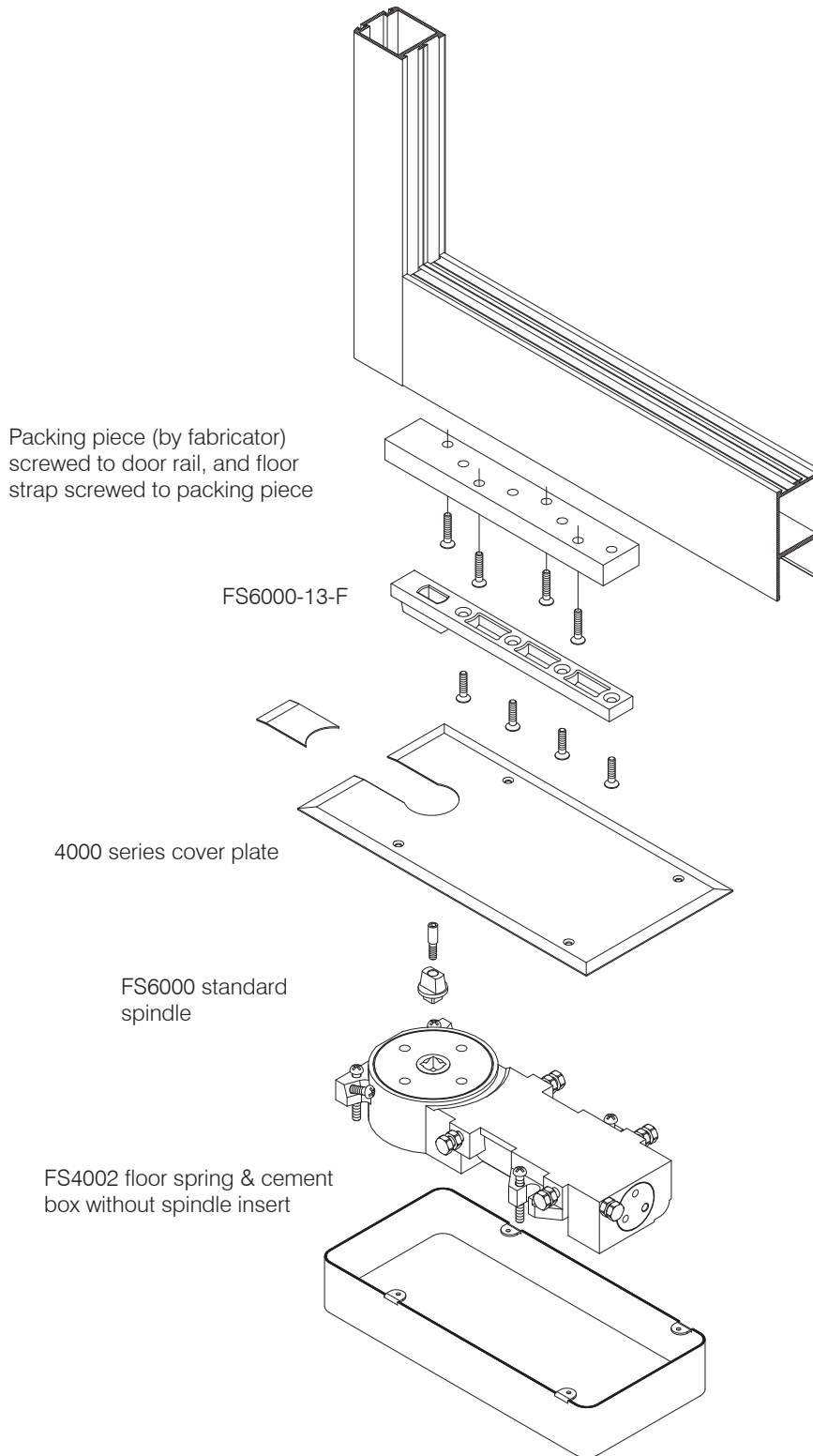

The Parkside Group Ltd

The Willow Centre  
17 Willow Lane, Mitcham, Surrey, CR4 4NX  
Tel: 020-8685 9685 Fax: 020-8646 5096  
Email: axim@parksidegroup.co.uk  
Web Site: www.axim.co.uk

SCALE NTS @A4

DATE MARCH 2014

For scaled technical or CAD drawings,  
please contact AXIM.

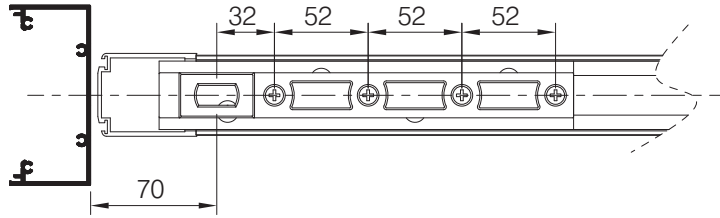

View on bottom of door

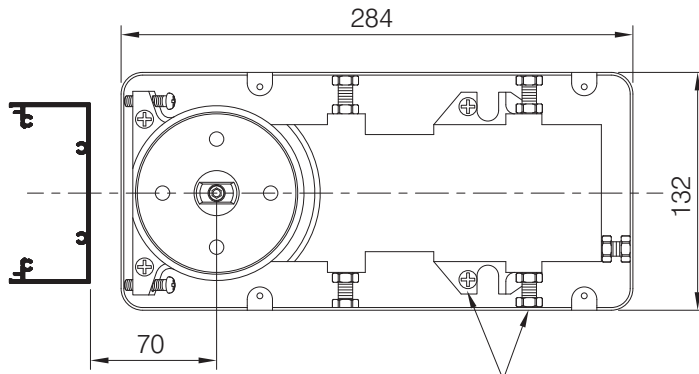

Set floor spring central in cement box before setting pivot point position

Adjustment screws

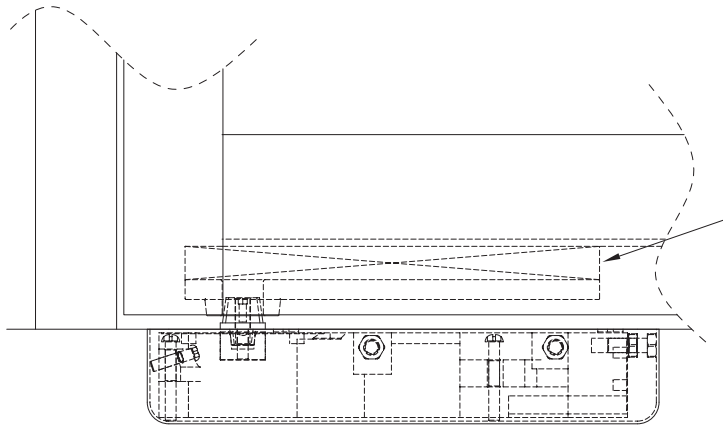

Packing piece

Set cement box level with finished floor level

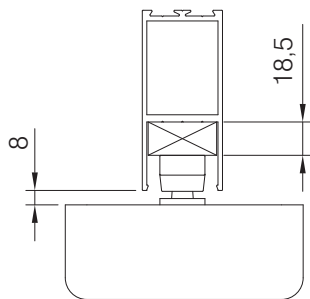

Maintain 8mm clearance between bottom of door and finished floor level, when using woolpile carrier, by adjusting height of packing piece

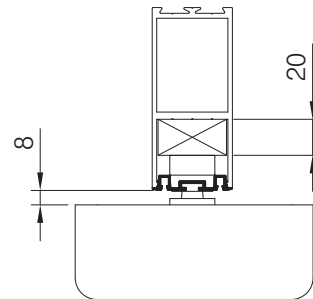

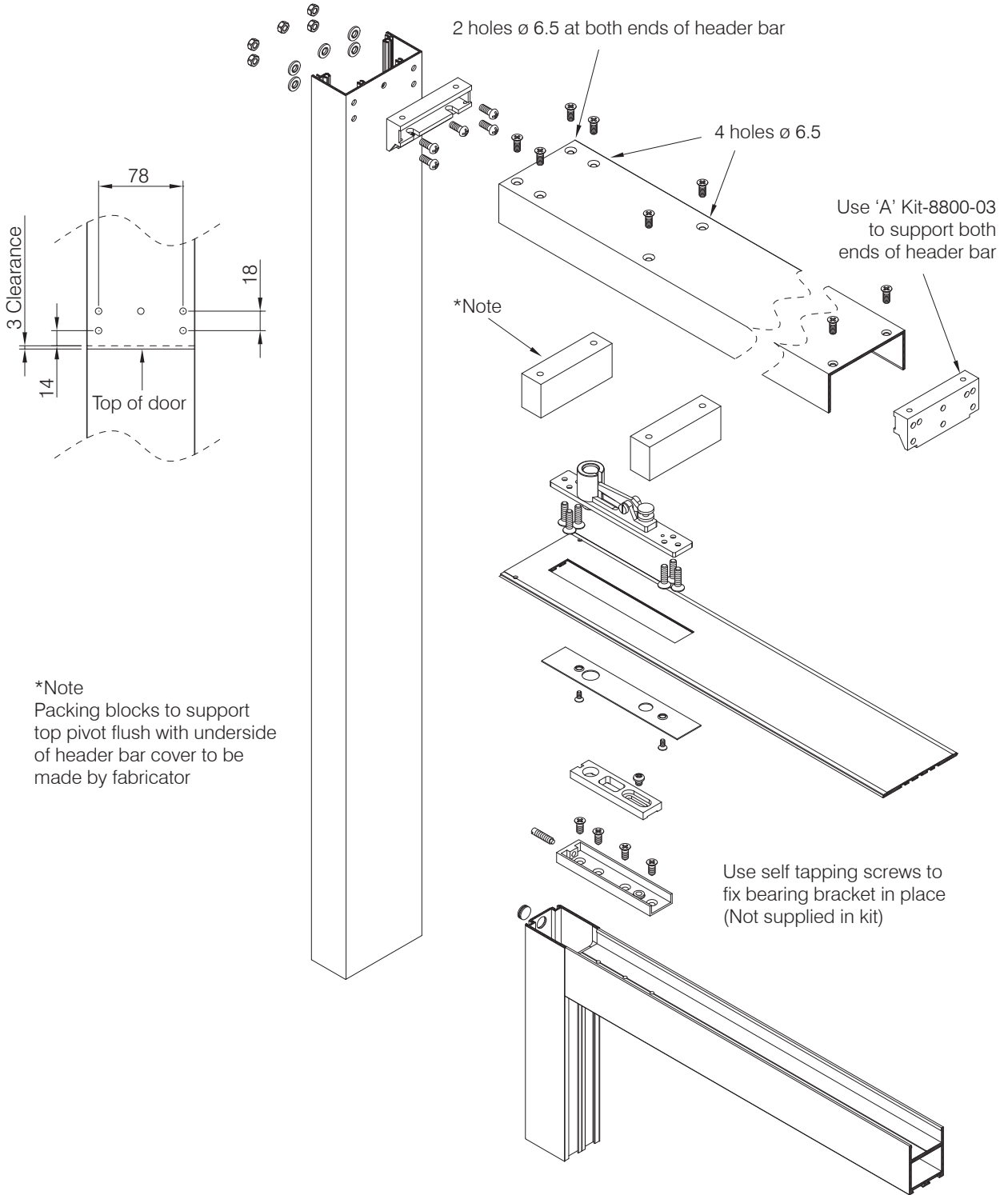

**The Parkside Group Ltd**  
 The Willow Centre  
 17 Willow Lane, Mitcham, Surrey, CR4 4NX  
 Tel: 020-8685 9685 Fax: 020-8646 5096  
 Email: axim@parksidegroup.co.uk  
 Web Site: www.axim.co.uk

SCALE	NTS @A4
DATE	MARCH 2014
For scaled technical or CAD drawings, please contact AXIM.	

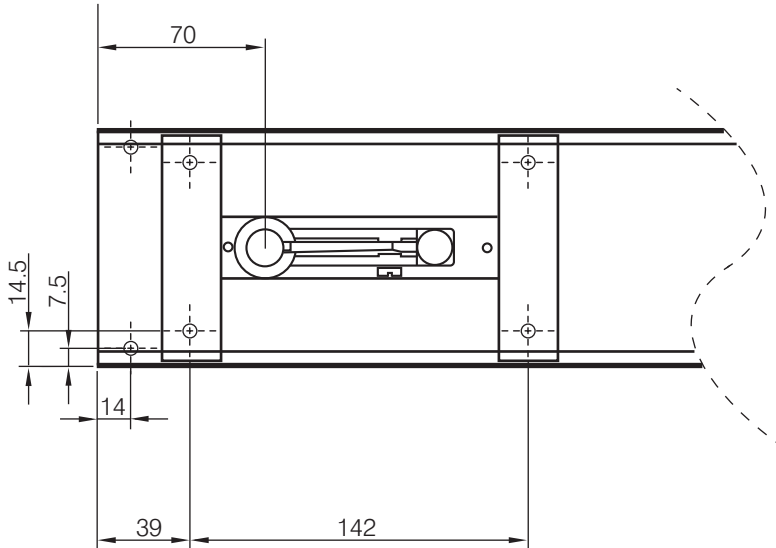

Blocks (by fabricator) drilled and tapped to suit top pivot

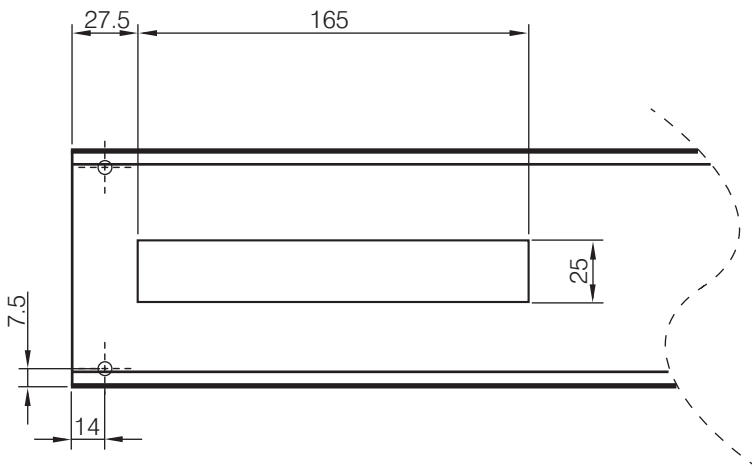
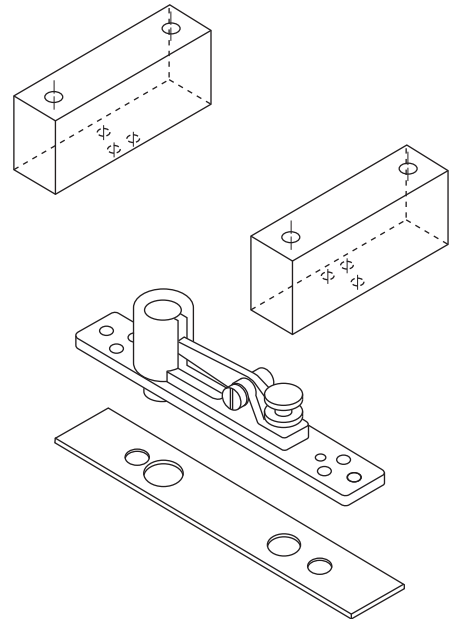

Note:  
For anti finger trap doors with auto closers  
use AXIM TC8800 dummy transom closer with  
standard bottom pivot

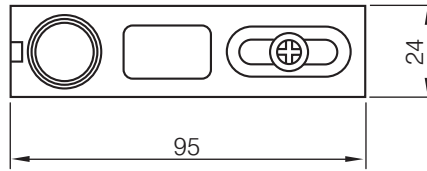

AXIM FS-6000-0115

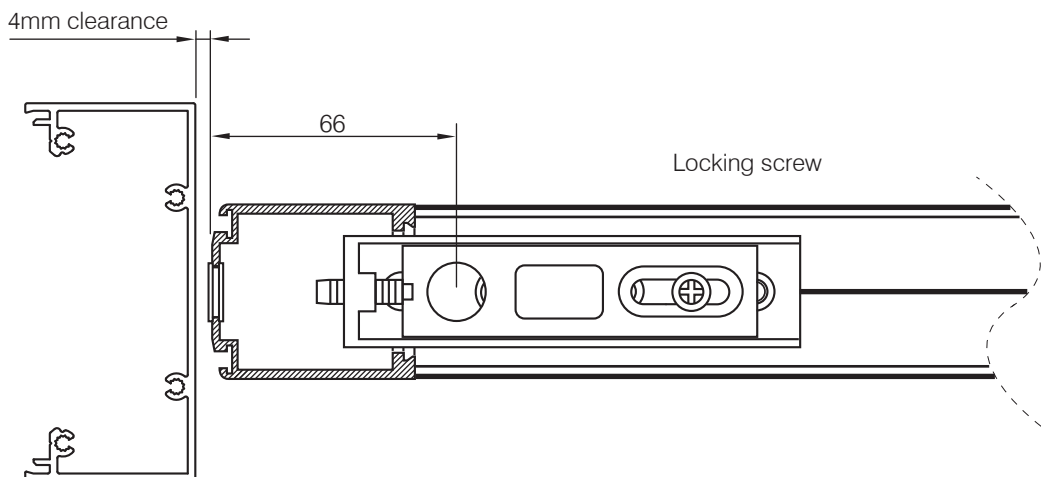
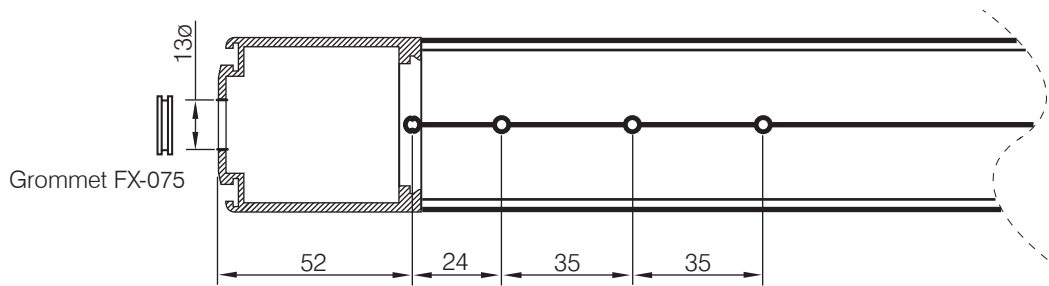
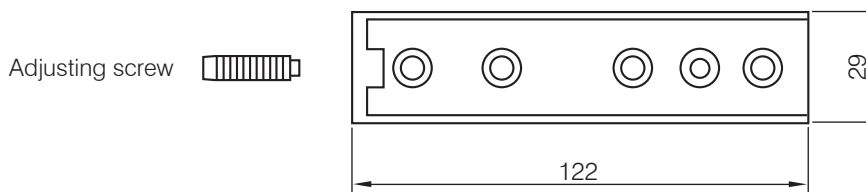



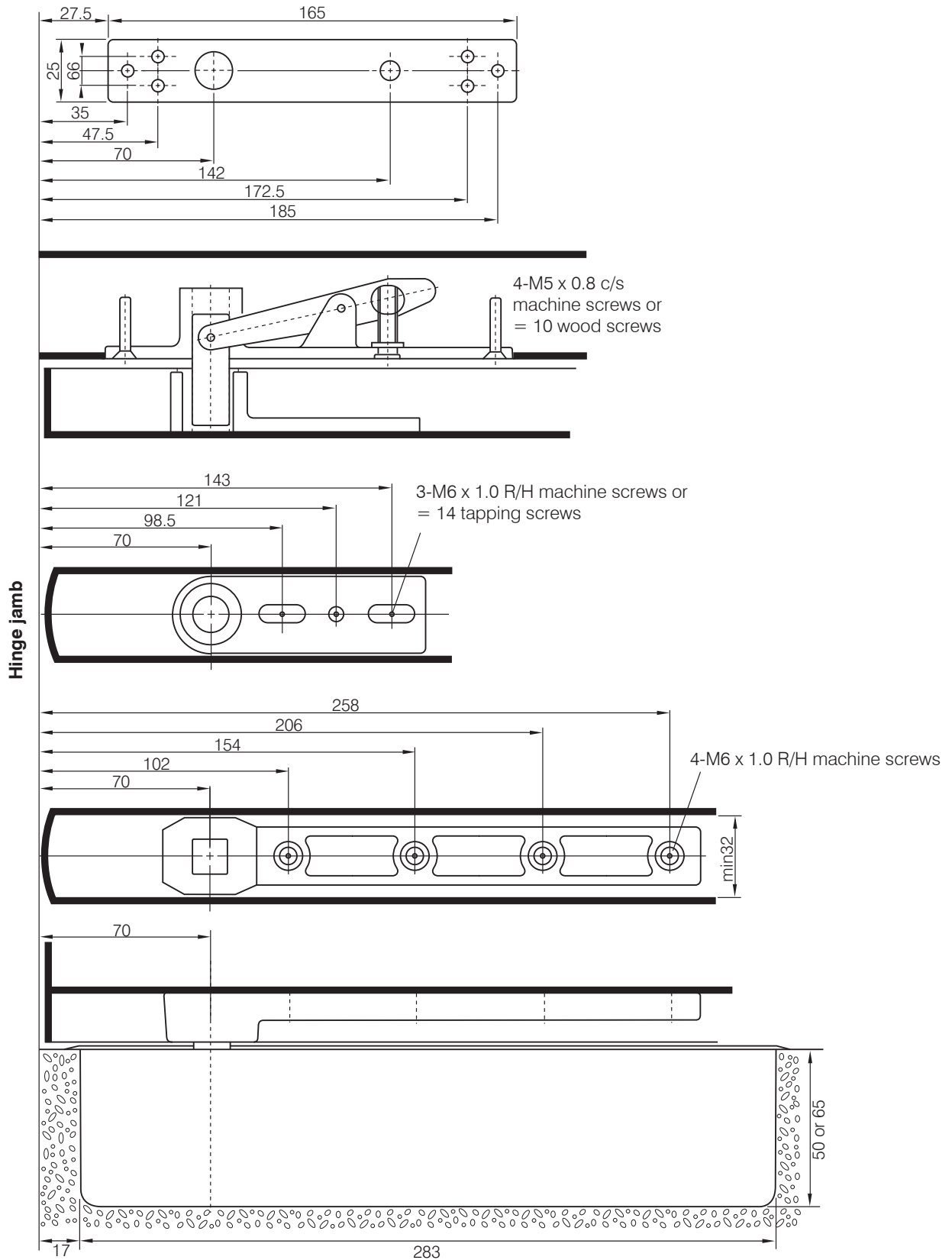

**The Parkside Group Ltd**

The Willow Centre  
17 Willow Lane, Mitcham, Surrey, CR4 4NX  
Tel: 020-8685 9685 Fax: 020-8646 5096  
Email: axim@parksidegroup.co.uk  
Web Site: www.axim.co.uk

SCALE NTS @A4

DATE MARCH 2014

For scaled technical or CAD drawings,  
please contact AXIM.

**UNIVERSAL APPLICATION**

Left hand, right hand, single and double action doors.  
Closing force 28 Nm for doors 150kg and up to 1200mm wide.  
No hold and 90° hold open options.

**FULLY HYDRAULIC CONTROL**

Provided by two valve screws  
Back check range 180°-70°   
Closing Range 70°-15°   
Latching Range 15°-0°

**BACKCHECK ZONE**

Prevents damage to outward opening doors or where door swing is limited to 90°.

**ADJUSTMENT**

With zinc plated cement box length 6mm, width 6mm, height 4mm.

**SPINDLE INSERT EXTENSIONS**

Up to 50mm, suitable for all types of doors.

**SPECIAL ORDER OPTIONS**

Hold open 85°, 105° and 120°.  
Light spring 15 Nm (for narrow width and light doors).

**SIZE SELECTION CHART**

DOOR WIDTH in mm	SPRING STRENGTH	CLOSING FORCE in Nm (Kpm)	NO HOLD OPEN	HOLD OPEN 90°
			PRODUCT CODE	
800 to 1200	Medium	28 (2.8)	6002-00	6002-90
Up to 800	Light	15 (1.5)	6001-00	6002-90

Select medium spring for standard doors up to 1200mm wide up to 150kg.  
Light spring for light or narrow internal doors.

**ADJUSTMENT**

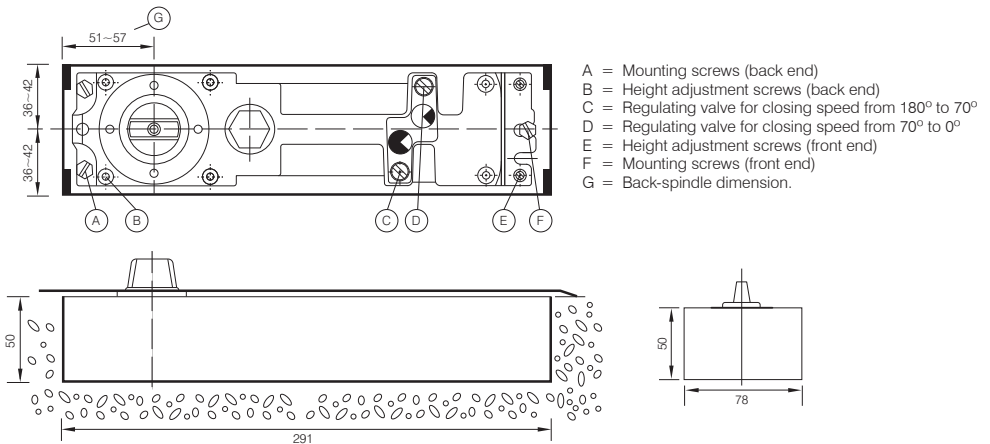

**CLOSING RANGE**

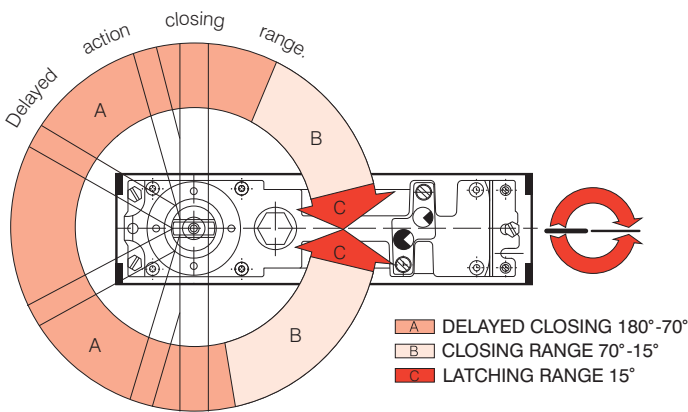

**Left-hand door**

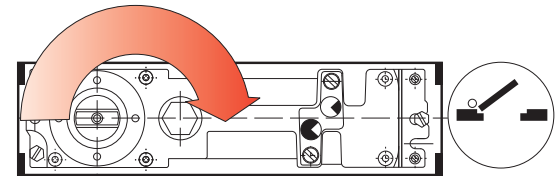

**Right-hand door**

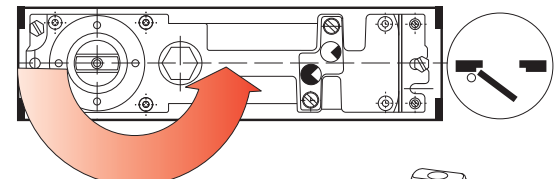

**FULL HYDRAULIC CONTROL**

Provided by three valve screws.

**COVER PLATES**

Universal for left hand, right hand single and double action doors. Three finishes available, stainless steel, Polished brass and B.M.A. (bronze).

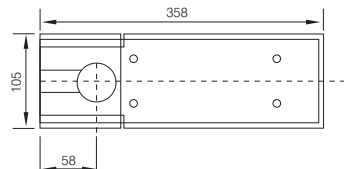

**SPINDLE INSERT EXTENSIONS**

Up to 50mm suitable for all types of doors.

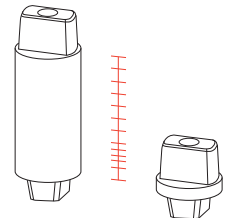

**GUARANTEE**

AXIM FLOOR SPRINGS ARE GUARANTEED FOR 30 MONTHS FROM THE DATE OF MANUFACTURE AGAINST DEFECT IN MATERIAL AND WORKMANSHIP. THIS GUARANTEE IS VOID IF THE PRODUCT HAS BEEN INCORRECTLY INSTALLED OR DAMAGED IN USE. CLAIMS FOR DAMAGE INCURRED OR WORK DONE THEREON WILL NOT BE ACCEPTED. AXIM RESERVE THE RIGHT TO UPDATE ITS PRODUCT SPECIFICATIONS WITHOUT PRIOR NOTICE.



**The Parkside Group Ltd**

The Willow Centre  
17 Willow Lane, Mitcham, Surrey, CR4 4NX  
Tel: 020-8685 9685 Fax: 020-8646 5096  
Email: axim@parksidegroup.co.uk  
Web Site: www.axim.co.uk

SCALE	NTS @A4
DATE	MARCH 2014
For scaled technical or CAD drawings, please contact AXIM.	

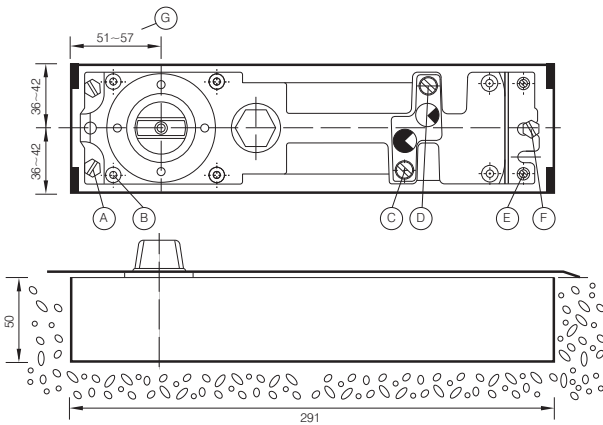

- A = Mounting screws (back end)
- B = Height adjustment screws (back end)
- C = Regulating valve for closing speed from 180° to 70°
- D = Regulating valve for closing speed from 70° to 0°
- E = Height adjustment screws (front end)
- F = Mounting screws (front end)
- G = Back-spindle dimension.

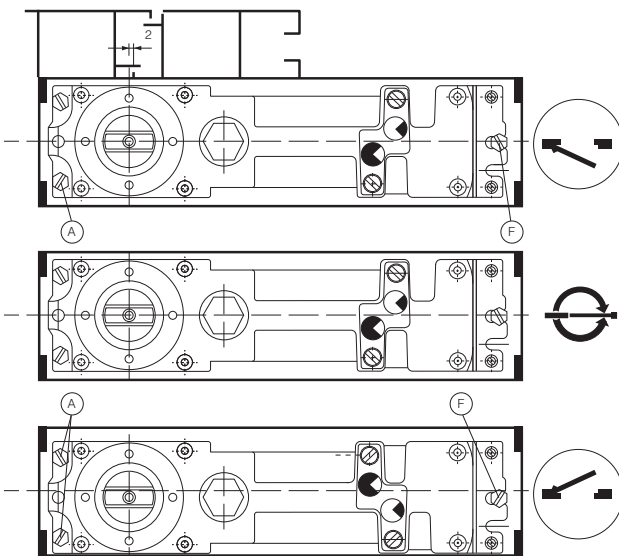

**Left-hand door**

Loosen mounting screws (A) and (E)  
Move closer in cement case as shown.

**Double action door**

Floor spring should be adjusted  
to centre of cement case.

**Right-hand door**

Loosen mounting screws (A) and (E)  
Move closer in cement case as shown.

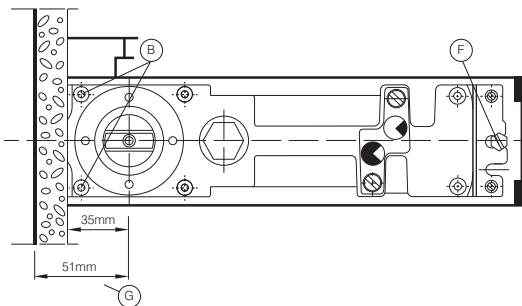

**Installation**

The back-spindle dimension (G) is 51mm and must be taken into consideration in regard to un-finished, or face concrete walls. After installation dimension (G) can be reduced to 35mm by means of tiles, stucco or other wall finishings.

**Removal**

Loosen height adjustment screws (B) and remove mounting screws (E). Now remove closer. Re-mounting; re-adjust closer. Tighten mounting screws (E) and height adjustment screw (B).

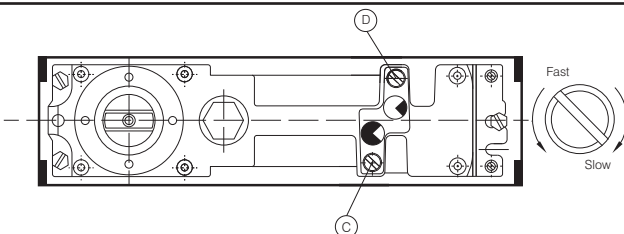

**Closing speed**

The FS6000 has two closing speeds which are independently adjustable.

Regulating valve (C) controls the closing speed from 180° ~ 70°.

Regulating valve (D) = 70° ~ 0° closed.



Accessories Installation drawings showing various accessories are available for all known aluminum-, stainless steel, toughened glass-, wood-, plastic- and steel doors.

**The Parkside Group Ltd**

The Willow Centre  
17 Willow Lane, Mitcham, Surrey, CR4 4NX  
Tel: 020-8685 9685 Fax: 020-8646 5096  
Email: axim@parksidegroup.co.uk  
Web Site: www.axim.co.uk

SCALE	NTS @A4
DATE	AUGUST 2017
For scaled technical or CAD drawings, please contact AXIM.	

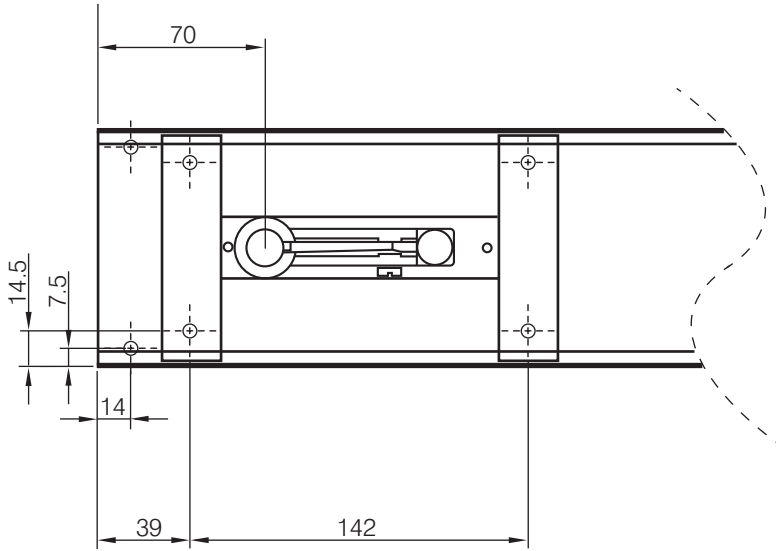

Blocks (by fabricator) drilled and tapped to suit top pivot

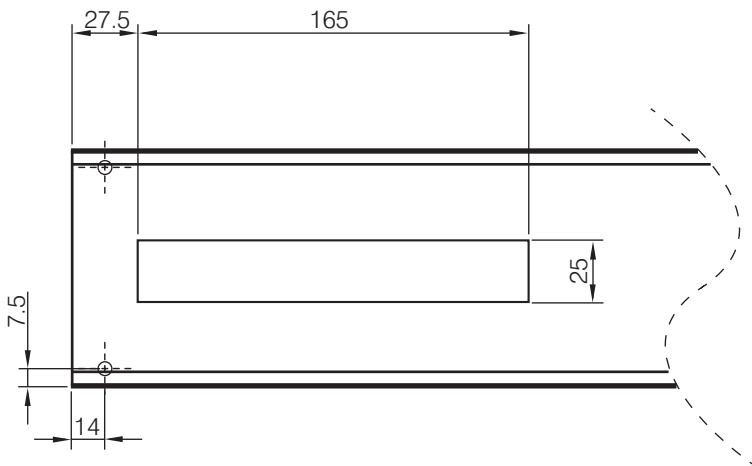
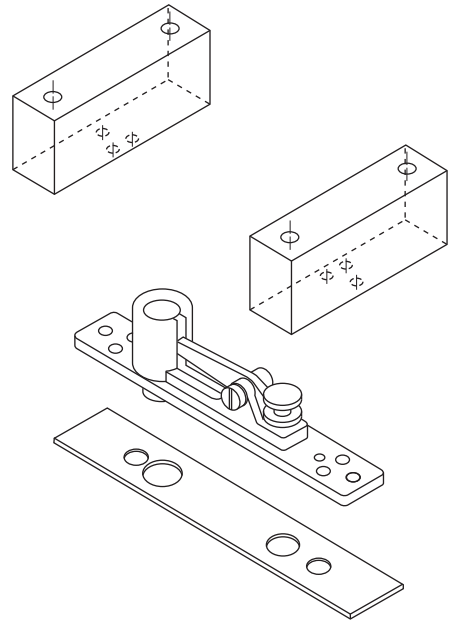

**The Parkside Group Ltd**

The Willow Centre  
17 Willow Lane, Mitcham, Surrey, CR4 4NX  
Tel: 020-8685 9685 Fax: 020-8646 5096  
Email: [axim@parksidegroup.co.uk](mailto:axim@parksidegroup.co.uk)  
Web Site: [www.axim.co.uk](http://www.axim.co.uk)

SCALE	NTS @A4
DATE	MARCH 2014
For scaled technical or CAD drawings, please contact AXIM.	

Note:  
For anti finger trap doors with auto closers  
use AXIM TC8800 dummy transom closer with  
standard bottom pivot

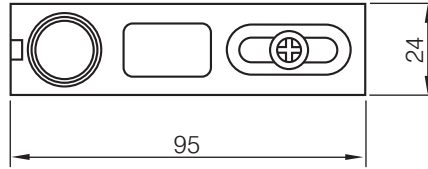

AXIM FS-6000-0115

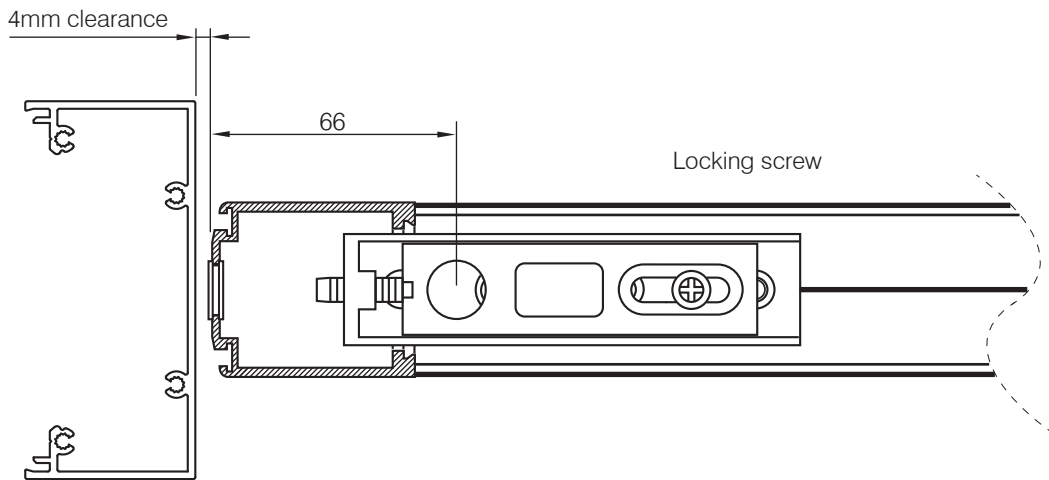
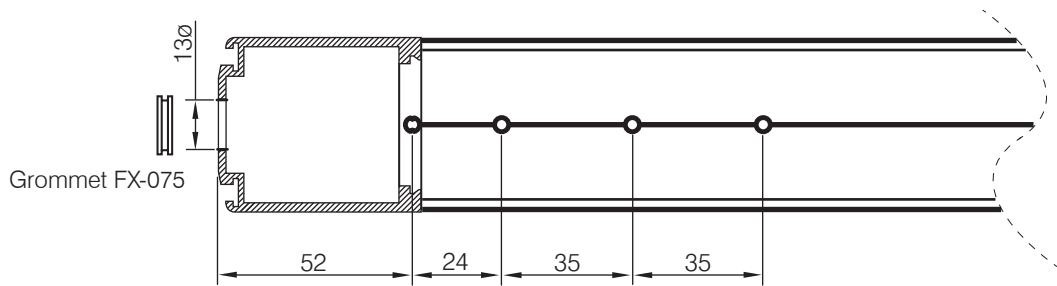
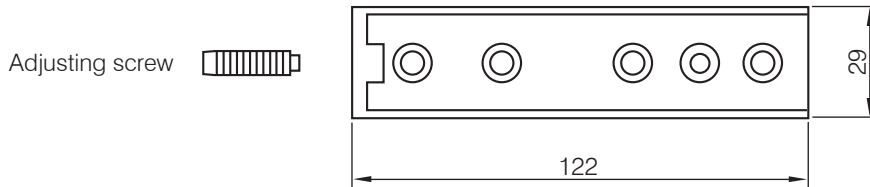

The Parkside Group Ltd

The Willow Centre  
17 Willow Lane, Mitcham, Surrey, CR4 4NX  
Tel: 020-8685 9685 Fax: 020-8646 5096  
Email: axim@parksidegroup.co.uk  
Web Site: www.axim.co.uk

SCALE	NTS @A4
DATE	MARCH 2014

For scaled technical or CAD drawings,  
please contact AXIM.

**UNIVERSAL APPLICATION**

Left hand, right hand, single and double action doors.  
Closing force 28 Nm for doors 120kg and up to 1150mm wide.  
No hold and 90° hold open options.  
105° hold open are available at request.

**FULLY HYDRAULIC CONTROL**

Provided by two valve screws   
Back check range 85°-130°   
Closing Range 130°-15°   
Latching Range 15°-0°

**BACKCHECK ZONE**

Prevents damage to outward opening doors or where door swing is limited to 90°.

**FULLY ADJUSTABLE**

The 8500 series floor spring is positionally adjustable for height 4mm, width 10mm and length 6mm.

**SIZE SELECTION CHART**

DOOR WIDTH in mm	SPRING STRENGTH	CLOSING FORCE in Nm (Kpm)	NO HOLD OPEN	HOLD OPEN 90°
			PRODUCT CODE	
Up to 1150	Medium	25 (2.5)	8502-00	8502-90
Up to 800	Light	16 (1.6)	8501-00	8501-90

Select medium spring for standard doors up to 1150mm wide up to 120kg.  
Light spring for light or narrow internal doors.

**ADJUSTMENT**

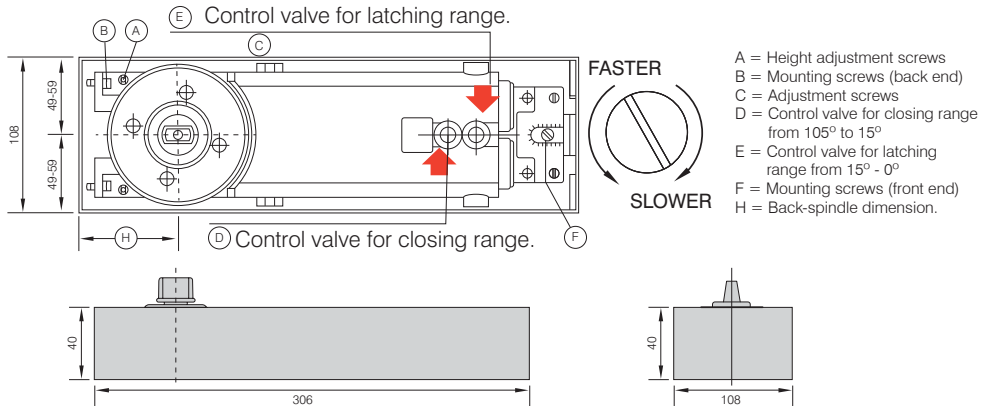

**CLOSING RANGE**

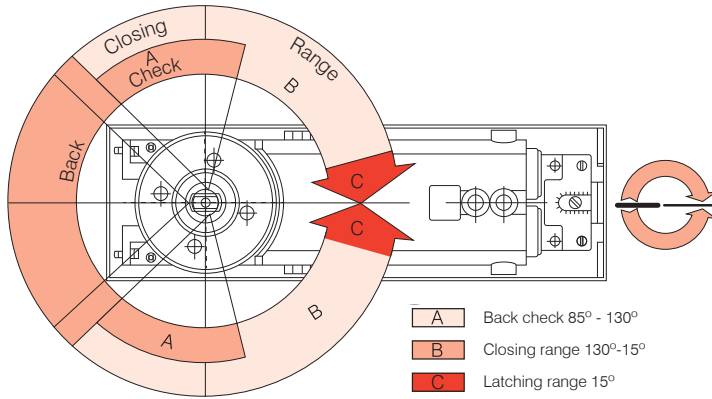

**Left-hand door**

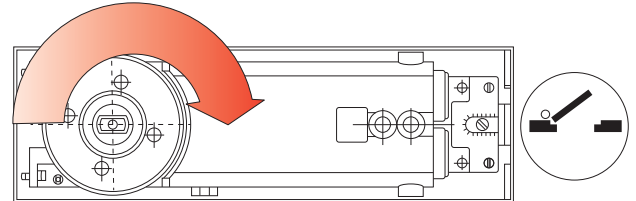

**Right-hand door**

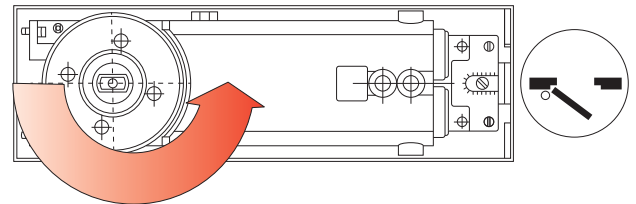

**GUARANTEE**

AXIM FLOOR SPRINGS ARE GUARANTEED FOR 30 MONTHS FROM THE DATE OF MANUFACTURE AGAINST DEFECT IN MATERIAL AND WORKMANSHIP. THIS GUARANTEE IS VOID IF THE PRODUCT HAS BEEN INCORRECTLY INSTALLED OR DAMAGED IN USE. CLAIMS FOR DAMAGE INCURRED OR WORK DONE THEREON WILL NOT BE ACCEPTED. AXIM RESERVE THE RIGHT TO UPDATE ITS PRODUCT SPECIFICATIONS WITHOUT PRIOR NOTICE.



**The Parkside Group Ltd**

The Willow Centre  
17 Willow Lane, Mitcham, Surrey, CR4 4NX  
Tel: 020-8685 9685 Fax: 020-8646 5096  
Email: axim@parksidegroup.co.uk  
Web Site: www.axim.co.uk

SCALE	NTS @A4
DATE	AUGUST 2017
For scaled technical or CAD drawings, please contact AXIM.	

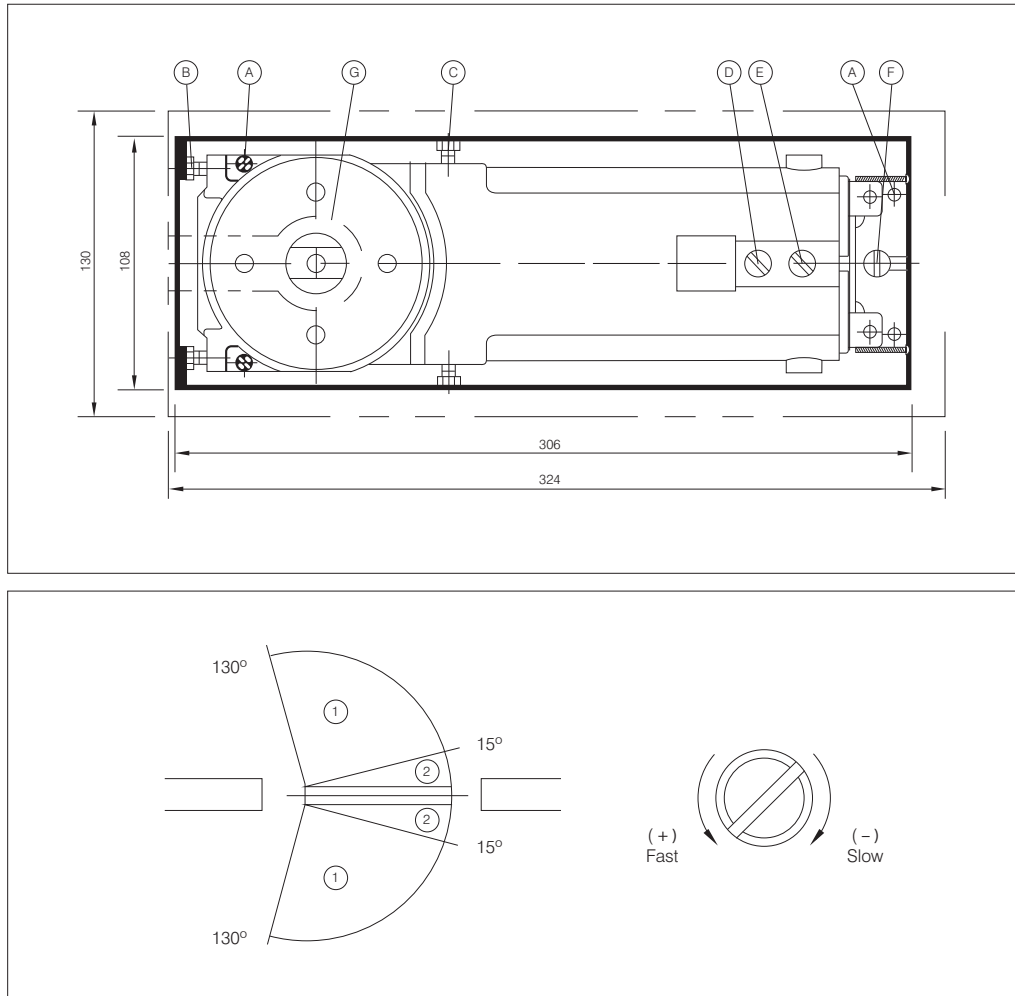

### Installation & Adjustment

- (1) Prepare frame and door rails as detailed and install door strap and pivot set.
- (2) Cut out recess in floor large enough for cement case and fit floor spring in position.  
Ensure spindle aligns with pivot pin in frame.  
Take dust plate (G) from coverplate pack and place over spindle before hanging door.
- (3) Lift door onto floor spring and open door enough to reveal pivot pin retracting screw.
- (4) Turn screw counter-clockwise until pin fully engages with pivot in door.
- (5) To adjust the clearance between hinge jamb and door stile, loosen screws (F), (C) and adjust with screws (B).
- (6) To adjust door height, loosen screws (F), (C), (B) and adjust with screws (A).
- (7) To centre door, loosen screws (B), (F) and adjust with screws (C).
- (8) To adjust the speed from 105° ~ 15° turn valve screw (D) counter-clockwise for faster and clockwise for slower.
- (9) For the last 15° of latching turn valve screw (E) counter-clockwise for faster and clockwise for slower.
- (10) Fit coverplate with 3 screws.



The Parkside Group Ltd

The Willow Centre  
17 Willow Lane, Mitcham, Surrey, CR4 4NX  
Tel: 020-8685 9685 Fax: 020-8646 5096  
Email: axim@parksidegroup.co.uk  
Web Site: www.axim.co.uk

SCALE	NTS @A4
DATE	MARCH 2014
For scaled technical or CAD drawings, please contact AXIM.	

# FS9500

Universal Application, Multi-Function Floor Hinge.

- One model, four optional spring strengths for every application
- Multiple functions as standard for reduced inventory
- Non-handed, for single or double action door
- Changeable spindle inserts available to suit field conditions
- Max. door weight up to 300kgs
- Hold-open angle available for 90° HO or NHO
- Mechanical Backcheck
- Closing speed variable by adjustable valve
- Max. door opening angle 180°

### Technical Data

Spring size		3	4	5
Closing Force	Nm	15	34	44
	Door Width (mm)	Up to 800	800~1200	1200~1400

Cement box : 341x78x60 mm  
(forward or backward total) : 6 mm

### Hold Open

Hold-open: Available for 90°, 105° or no hold open, Without hold open, the max door opening can be 180°.

### Backcheck

The backcheck helps to prevent damage of the door and wall when a door is opened with excessive force by people or the wind.

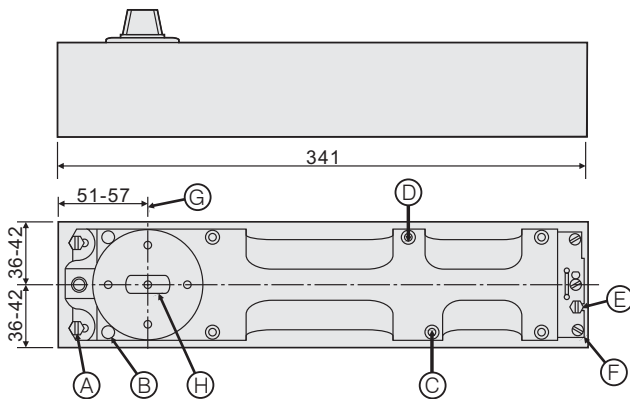
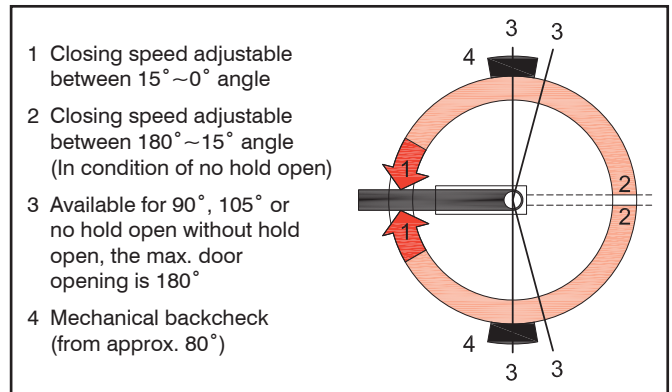

- A = Mounting Screws
- B = Height Adjustment Screws
- C = Latching Speed Valve
- D = Closing Speed Valve for Closing Speed
- E = Mounting Screws
- F = Height Adjustment Screws
- G = Spindle Backset Adjustment
- H = Changeable Spindle

1. Closing speed adjustable between 180°~15° angle
2. Latching speed adjustable between 15°~0° angle

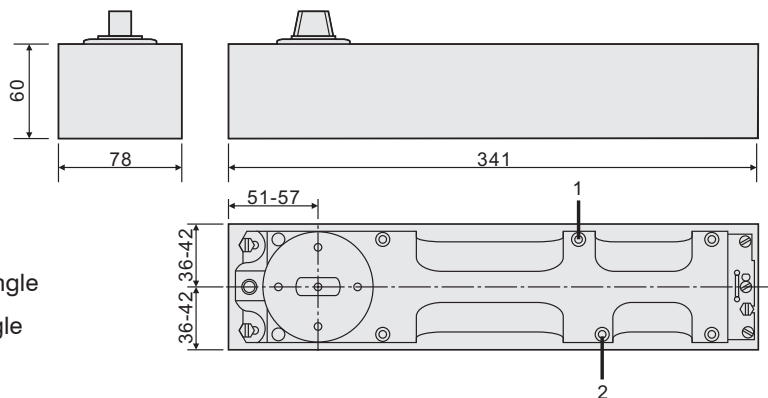
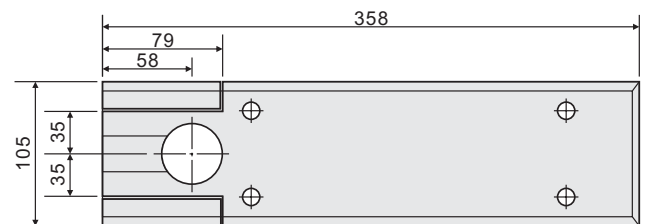

The Parkside Group Ltd

The Willow Centre  
17 Willow Lane, Mitcham, Surrey, CR4 4NX  
Tel: 020-8685 9685 Fax: 020-8646 5096  
Email: axim@parksidegroup.co.uk  
Web Site: www.axim.co.uk

SCALE NTS @A4  
DATE JULY 2017

For scaled technical or CAD drawings, please contact AXIM.



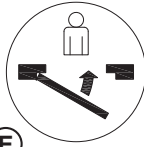
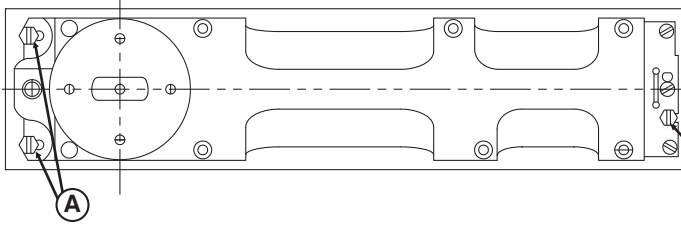

**Right Hand Door  
(Left-Hand Reverse Bevel)**  
Loosen mounting screws **(A)** and **(E)**  
Move closer in cement box as illustrated.

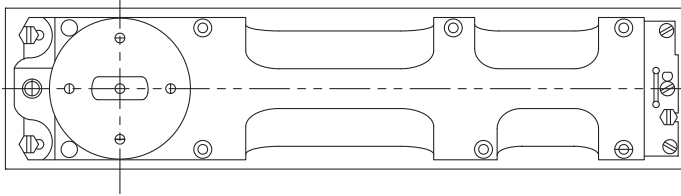

**Double Acting Door**  
Floor closer should be positioned in center of cement box.

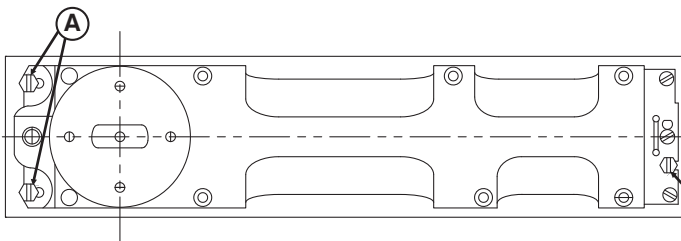

**Left-Hand Door  
(Right-Hand Reverse Bevel)**  
Loosen mounting screws **(A)** and **(E)**  
Move closer in cement box as illustrated.

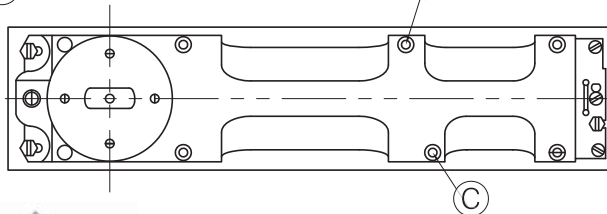
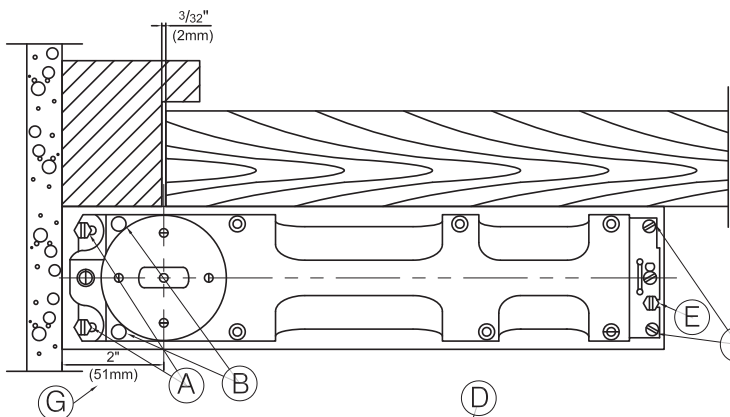
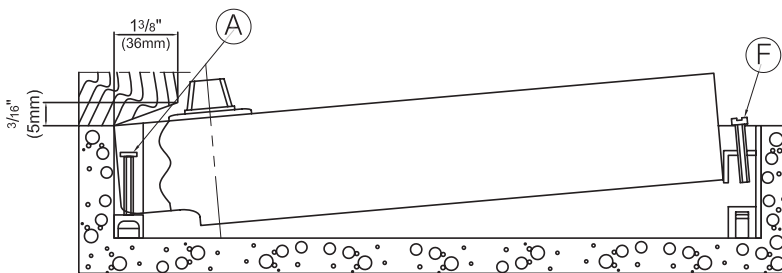

**Installation**

- 1 The cement case must be installed to allow for a pivot center-line dimension of  $2\frac{3}{4}$ " (70mm) backset from finished door jamb. The spindle backset **(G)** can be adjusted  $+\frac{1}{8}$ " (3mm) within the cement case.
- 2 The cement case top must be flush with the finished floor. The closer body can be raised approximately  $\frac{1}{8}$ " (3mm) with screws **(B)** & **(F)**. The Closer Must Remain Level. Use the appropriate spindle size to achieve the desired clearance.
- 3 Adjust the closer body as required for center-hung or offset applications. Use screws **(A)** & **(E)** to secure the closer body in the cement case.
- 4 Hold-open: available for 90°, 105° or no hold open. Without hold open, the max door opening can be 180°.

**Speed Adjustable**

- 1 **Valve D:** Closing speed adjustable between 180°~15° and (in condition of no hold open)
- 2 **Valve C:** Closing speed adjustable between 15°~0° angle



**The Parkside Group Ltd**

The Willow Centre  
17 Willow Lane, Mitcham, Surrey, CR4 4NX  
Tel: 020-8685 9685 Fax: 020-8646 5096  
Email: axim@parksidegroup.co.uk  
Web Site: www.axim.co.uk

SCALE	NTS @A4
DATE	JULY 2017
For scaled technical or CAD drawings, please contact AXIM.	





TITLE	<b>UNIVERSAL CLOSER FC-1000 SERIES</b>	SHEET No. <b>3:01</b>
SUB TITLE	<b>TECHNICAL INFORMATION</b>	

### SURFACE MOUNTED HYDRAULIC DOOR CLOSER

Die cast aluminium body, modern slimline design suitable for doors opening onto adjacent walls. Available in two strengths with one body size suitable for single action doors, either right hand or left hand opening 90° and 180°.

Reversible for standard top jamb and parallel arm installations.

Parallel arm bracket supplied as standard with every unit.

Fixings provided for both timber and metal doors.

Anodised dress plates conceal fixings after installation.

Easy to follow installation guide and full size template packed with every unit.

### ADJUSTMENT

Two valve screws provide full hydraulic control from 180° - 15° of closing and 15° - 0° latching.

### FIRE RATING

AXIM 1000 series closers have been included in successful fire tests to BS 476 Pt. 22 1987.

### AVAILABLE IN THREE FINISHES

- Silver.
- Dark bronze.
- Gold.
- Other colours available on special request.

### MODEL SELECTION TABLE (MAXIMUM DOOR WIDTH DIMENSION IN mm)

SIZE NO.	REGULAR ARM				PARALLEL ARM			DOOR WEIGHT (Ref.) kgs	
	INTERIOR DOOR	EXTERIOR DOOR		Closing Force Nm (kgf.m)	INTERIOR DOOR	EXTERIOR DOOR			Closing Force Nm (kgf.m)
		Swing Out	Swing In			Swing Out	Swing In		
2	900	800	700	19 (1.9)	800	700	600	14 (1.4)	25-45
3	1050	900	800	23 (2.3)	900	800	700	19 (1.9)	40-60

### ACCESSORIES

Hold open arm (plunger type) adjustable for any degree of retention.

Flat top bracket for installation on door frame when direct fixing is not possible.

### SPECIAL ORDER OPTIONS

Special purpose accessories are available to cover the most difficult of applications.

Further information on request.

### GUARANTEE

AXIM SURFACE MOUNTED CLOSERS AND ACCESSORIES ARE GUARANTEED FOR 30 MONTHS FROM THE DATE OF MANUFACTURE AGAINST DEFECT IN MATERIAL AND WORKMANSHIP. THIS GUARANTEE IS VOID IF THE PRODUCT HAS BEEN INCORRECTLY INSTALLED OR DAMAGED IN USE. CLAIMS FOR DAMAGE INCURRED OR WORK DONE THEREON WILL NOT BE ACCEPTED.

AXIM RESERVE THE RIGHT TO UPDATE ITS PRODUCT SPECIFICATIONS WITHOUT PRIOR NOTICE.



### The Parkside Group Ltd

The Willow Centre  
17 Willow Lane, Mitcham, Surrey, CR4 4NX  
Tel: 020-8685 9685 Fax: 020-8646 5096  
Email: axim@parksidegroup.co.uk  
Web Site: www.axim.co.uk

SCALE	NTS @A4
DATE	MARCH 2014
For scaled technical or CAD drawings, please contact AXIM.	

6 x clearance holes to suit M6 screws. Typ.

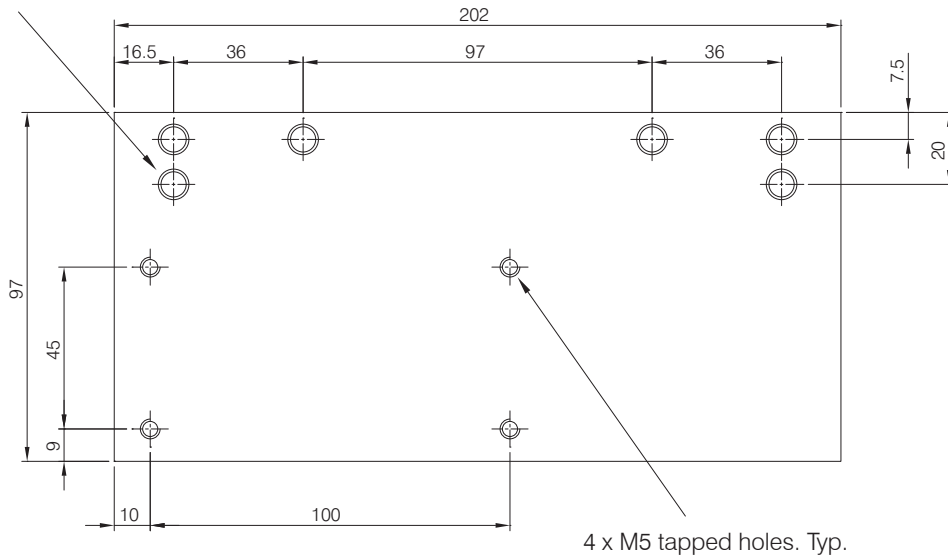

**FC-1000-12-AL**

Backplate for use with FC1000 series surface closers on parallel arm installation

4 x M5 tapped holes. Typ.

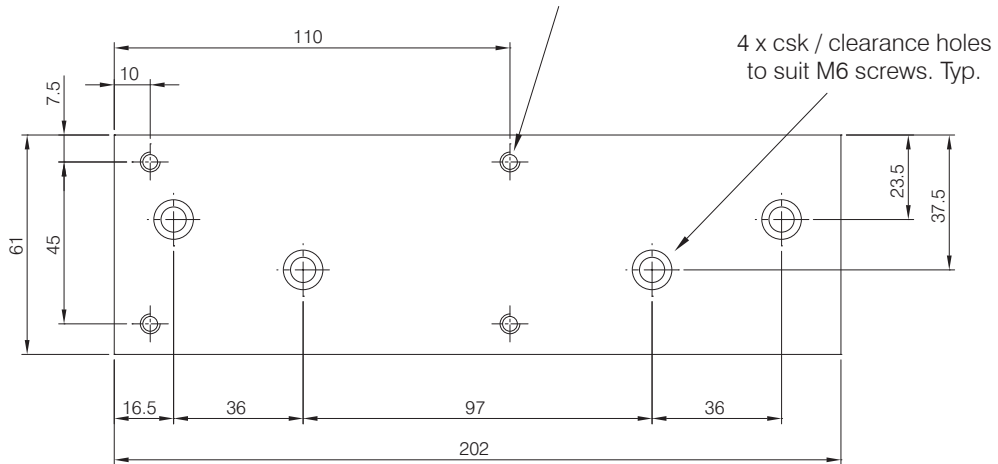

**FC-1000-14-AL**

Backplate for use with FC1000 series surface closers on standard and top jamb installation



The Parkside Group Ltd

The Willow Centre  
17 Willow Lane, Mitcham, Surrey, CR4 4NX  
Tel: 020-8685 9685 Fax: 020-8646 5096  
Email: axim@parksidegroup.co.uk  
Web Site: www.axim.co.uk

SCALE	NTS @A4
DATE	MARCH 2014
For scaled technical or CAD drawings, please contact AXIM.	

ISO view not to scale

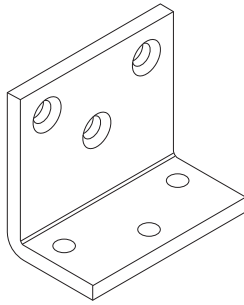

**Material:** Mild steel  
**Finish:** Zinc plating + silver,  
bronze or white PPC

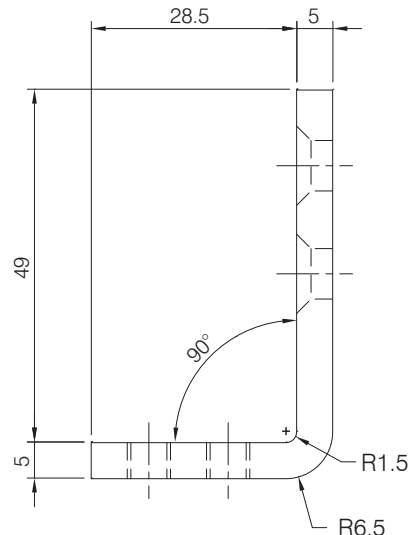
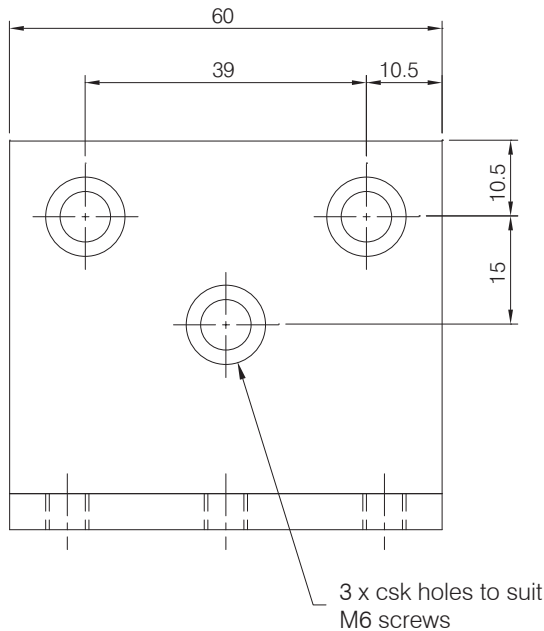
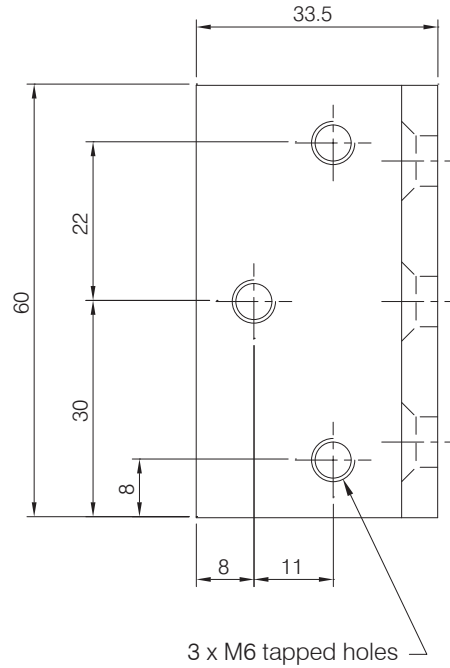

**The Parkside Group Ltd**

The Willow Centre  
17 Willow Lane, Mitcham, Surrey, CR4 4NX  
Tel: 020-8685 9685 Fax: 020-8646 5096  
Email: axim@parksidegroup.co.uk  
Web Site: www.axim.co.uk

SCALE	NTS @A4
DATE	MARCH 2014
For scaled technical or CAD drawings, please contact AXIM.	

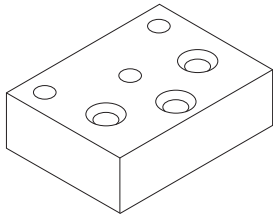

ISO view not to scale

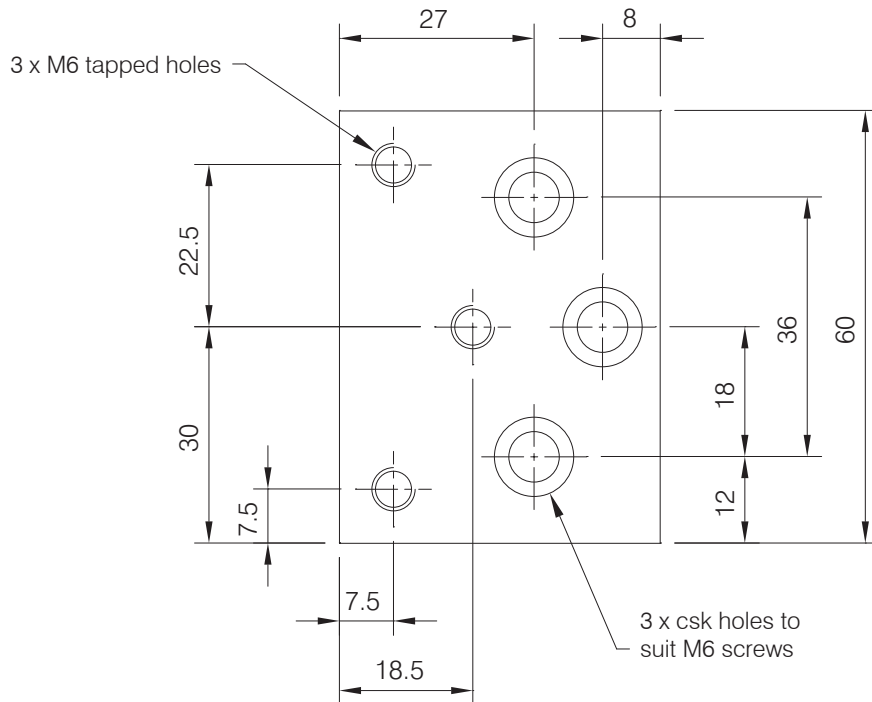
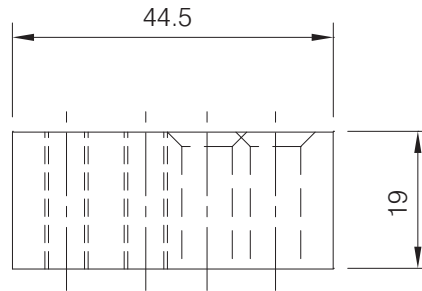

**Material:** Aluminium  
**Finish:** Mill finish



The Parkside Group Ltd

The Willow Centre  
17 Willow Lane, Mitcham, Surrey, CR4 4NX  
Tel: 020-8685 9685 Fax: 020-8646 5096  
Email: axim@parksidegroup.co.uk  
Web Site: www.axim.co.uk

SCALE NTS @A4

DATE MARCH 2014

For scaled technical or CAD drawings,  
please contact AXIM.

**Standard installation**

Closer mounted on door on pull side

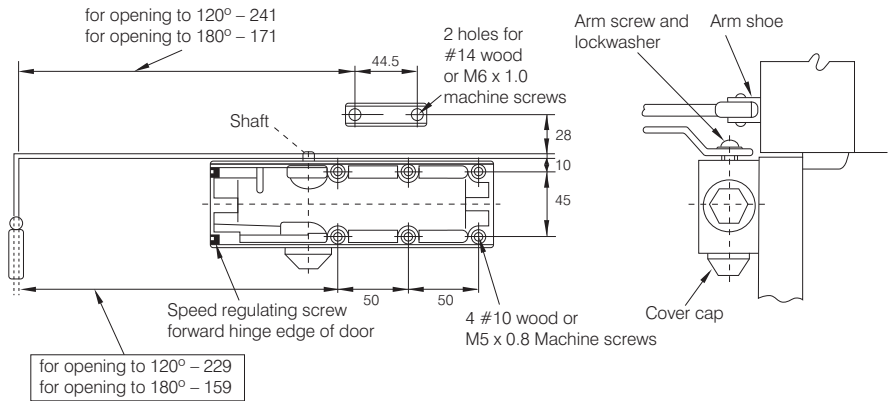
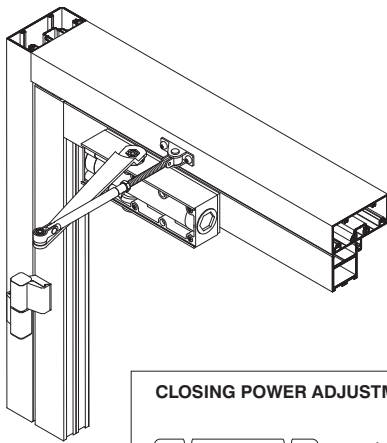

**CLOSING POWER ADJUSTMENT**

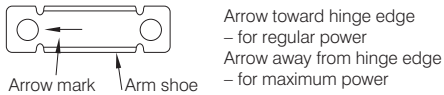

**Right hand door shown**  
Same dimensions apply for left hand door measured from hinge edge

**POSITION OF ARMS AND INDEX SETTINGS**

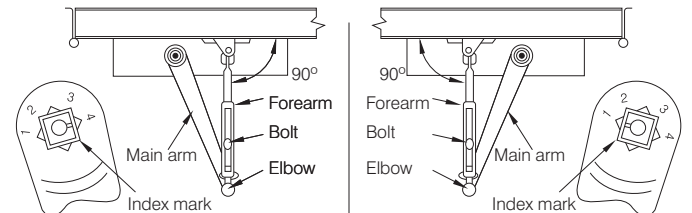

**Top jamb installation**

Closer mounted on top jamb on push side of door.  
Reveals of 70 to 127 requires long top jamb forearms

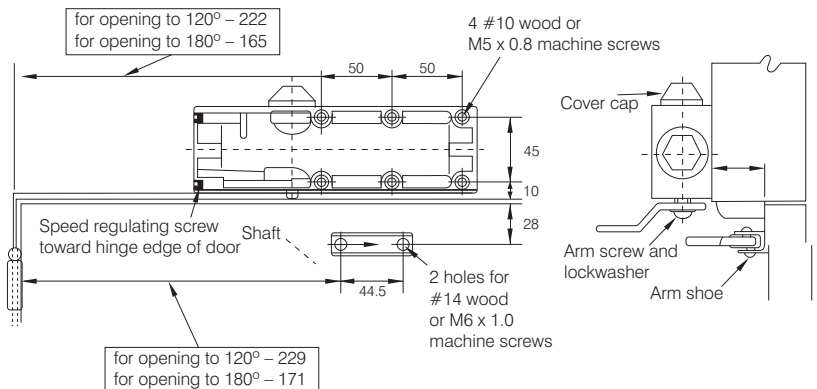
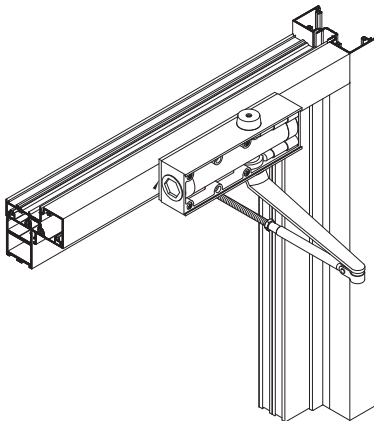

**CLOSING POWER ADJUSTMENT**

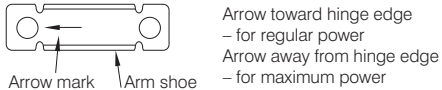

**Left hand door shown**  
Same dimensions apply for right hand door measured from hinge edge

**POSITION OF ARMS AND INDEX SETTINGS**

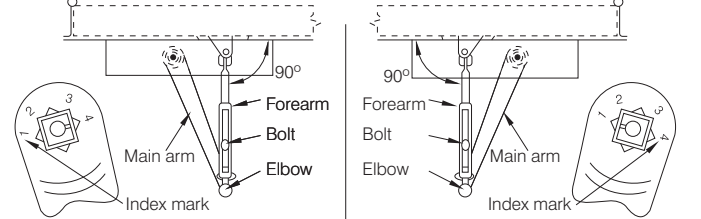

**The Parkside Group Ltd**

The Willow Centre  
17 Willow Lane, Mitcham, Surrey, CR4 4NX  
Tel: 020-8685 9685 Fax: 020-8646 5096  
Email: axim@parksidegroup.co.uk  
Web Site: www.axim.co.uk

SCALE NTS @A4

DATE MARCH 2014

For scaled technical or CAD drawings,  
please contact AXIM.

**Parallel arm installation**

Closer mounted on door on push side

**Left hand door shown**

Same dimensions apply for right hand door measured from hinge edge.

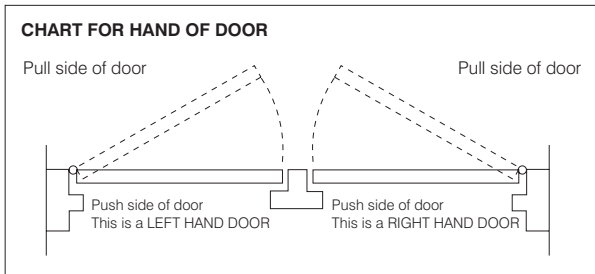
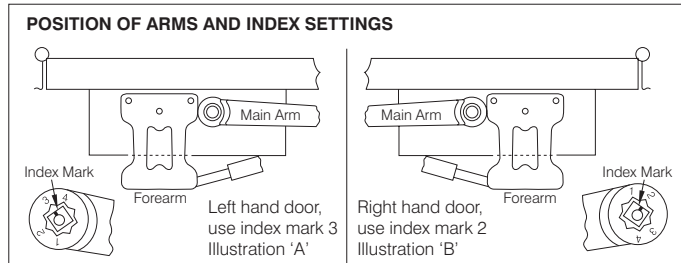
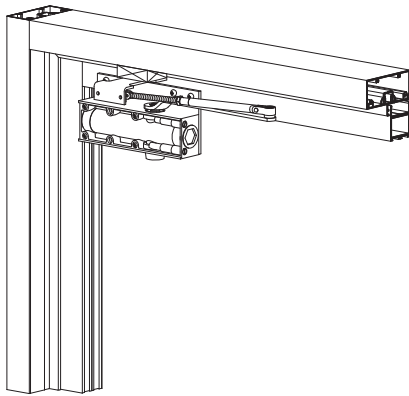
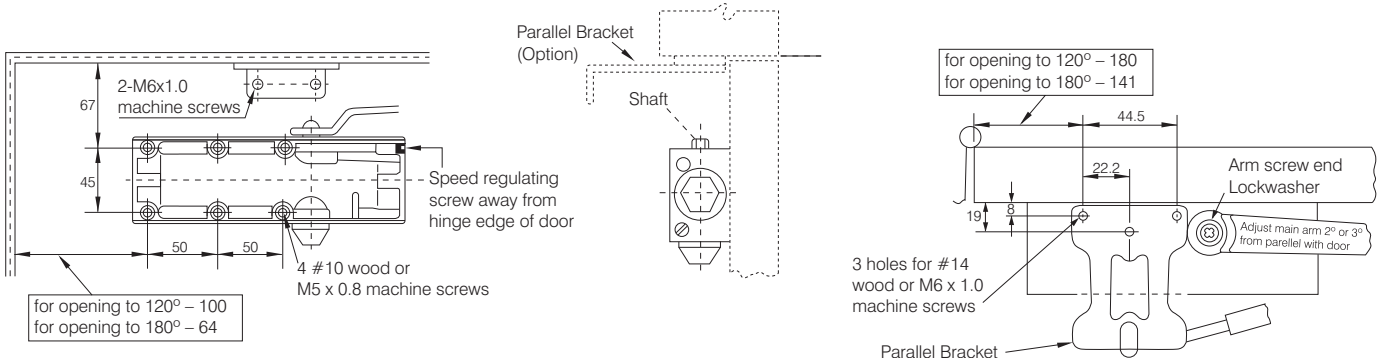

**Instructions**

**Step 1**

- A. Check hand of door.
- B. Select type of installation.

**Step 2**

- A. See instructions for installation you have selected.
- B. Follow instructions for correct application and adjustment.

**Step 3**

- A. Apply closer body and forearm (or parallel bracket and forearm) to door and frame as shown.
- B. Place main arm on shaft at proper index mark as shown and tighten arm screw with lockwasher securely.
- C. Adjust length of forearm as shown and attach to main arm at elbow and tighten locknut bolt.

**Step 4**

Fixing cover cap on shaft at unused side and insert rubber plug into one of unused fixing hole on body then slide in the Faceplate.

**Step 5**

Door closing and latching speeds are controlled by #1, #2 speed regulating screw separately.

- A. Clockwise turns slow the Speed.
- B. Counterclockwise turns increase the speed.

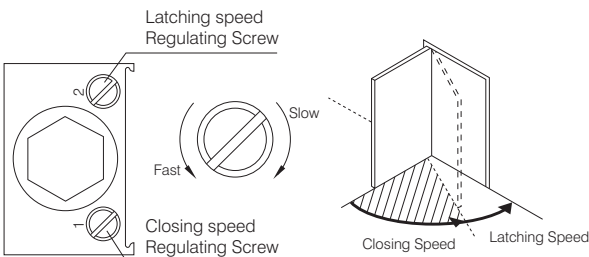

**The Parkside Group Ltd**

The Willow Centre  
17 Willow Lane, Mitcham, Surrey, CR4 4NX  
Tel: 020-8685 9685 Fax: 020-8646 5096  
Email: axim@parksidegroup.co.uk  
Web Site: www.axim.co.uk

SCALE	NTS @A4
DATE	MARCH 2014
For scaled technical or CAD drawings, please contact AXIM.	



**SURFACE MOUNTED HYDRAULIC  
DOOR CLOSER**

The FC-15 is a multi-strength surface mounted hydraulic door closer, designed to complement the FC-10. A hardened rack and pinion mechanism is housed in a die cast aluminium body.

Suitable for left or right hand opening doors, top jamb and standard fixing. A parallel bracket is supplied for parallel arm installations.

Fixings for both metal and timber doors are included.

Adjustment valve screws and fixings are concealed behind a slide on, anodised dress plate. Each unit is complete with a full size template and easy to follow instructions.

**ADJUSTMENT**

Backcheck is a standard feature which protects doors in severe conditions.

The cushioning effect has been set for average conditions but can be increased or decreased by turning (valve screw D) clockwise or counterclockwise.

Closing speed is adjustable from 180-15° by turning (valve screw B) counterclockwise for faster or clockwise for slower

The latching (valve screw C) can be adjusted in the same way for the last 15° of closing.

**DELAYED ACTION**

Delayed action is available as an option giving a timed hold open from 180-70° allowing unhindered access, particularly useful on hospital doors. The speed is also adjustable using (valve screw E) in the same way as the closing and latching valves. Spring power is adjustable giving sizes 2-5 by tuning (screw F) with the 5mm hexagon wrench provided. See adjustment chart.

**TEST VERIFICATION OF CONFORMITY**

AXIM 1500 series closers have been included in successful tests to EN 1154: 1996.

**AVAILABLE IN THREE FINISHES**

- Silver.
- Dark bronze.
- White.
- Other colours available on special request.

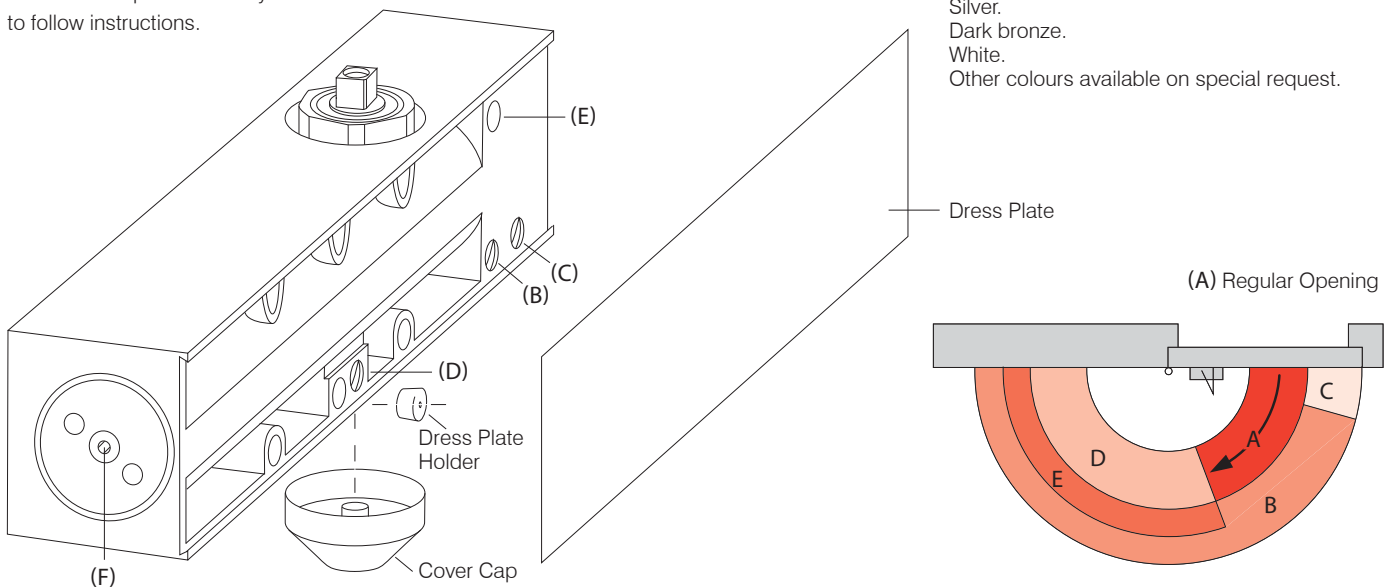

No. of turned	Power size	STANDARD/TOP JAMB INSTALLATION				Power size	PARALLEL INSTALLATION				Door weight (Kgs)
		Interior door width (mm)	Exterior door width (mm)		Closing force (Kgf.m)		Interior door width (mm)	Exterior door width (mm)		Closing force (Kgf.m)	
			Swing out	Swing in			Swing out	Swing in			
-3	2	900	800	700	1.2	1	900	800	600	1.2	25-45
0	3	1050	900	800	1.9	2	1050	700	700	1.9	40-65
+4	4	1200	1050	900	2.9	3	1200	900	800	2.9	60-85
+8	5	1350	1200	1050	3.8	4	1350	1200	1050	3.8	80-60

\*Factory preset

**ACCESSORIES**

Hold open arm (plunger type) adjustable for any degree of retention.

Flat top bracket for installation on door frame when direct fixing is not possible.

**SPECIAL ORDER OPTIONS**

Special purpose accessories are available to cover the most difficult of applications.

For special widths, a FC-1600 closer is available.

Please contact Technical Department for further information.

**GUARANTEE**

AXIM SURFACE MOUNTED CLOSERS AND ACCESSORIES ARE GUARANTEED FOR 30 MONTHS FROM THE DATE OF MANUFACTURE AGAINST DEFECT IN MATERIAL AND WORKMANSHIP. THIS GUARANTEE IS VOID IF THE PRODUCT HAS BEEN INCORRECTLY INSTALLED OR DAMAGED IN USE. CLAIMS FOR DAMAGE INCURRED OR WORK DONE THEREON WILL NOT BE ACCEPTED. AXIM RESERVE THE RIGHT TO UPDATE ITS PRODUCT SPECIFICATIONS WITHOUT PRIOR NOTICE.



**The Parkside Group Ltd**

The Willow Centre  
17 Willow Lane, Mitcham, Surrey, CR4 4NX  
Tel: 020-8685 9685 Fax: 020-8646 5096  
Email: axim@parksidegroup.co.uk  
Web Site: www.axim.co.uk

SCALE	NTS @A4
DATE	AUGUST 2017
For scaled technical or CAD drawings, please contact AXIM.	

**POSITION OF ARMS AND INDEX SETTINGS**

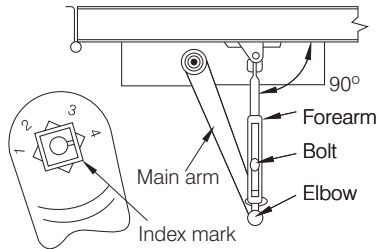

Right hand door. Use index mark 4

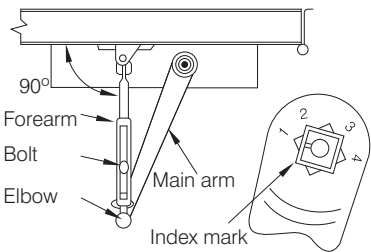

Left hand door. Use index mark 1

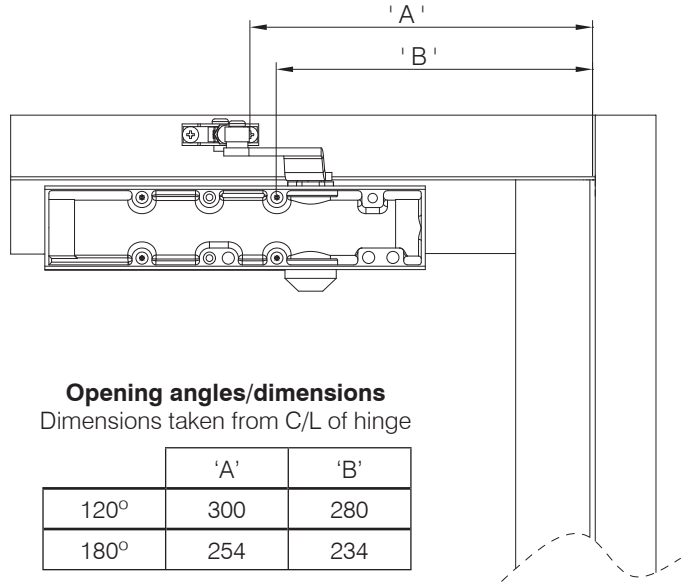

**Opening angles/dimensions**  
Dimensions taken from C/L of hinge

	'A'	'B'
120°	300	280
180°	254	234

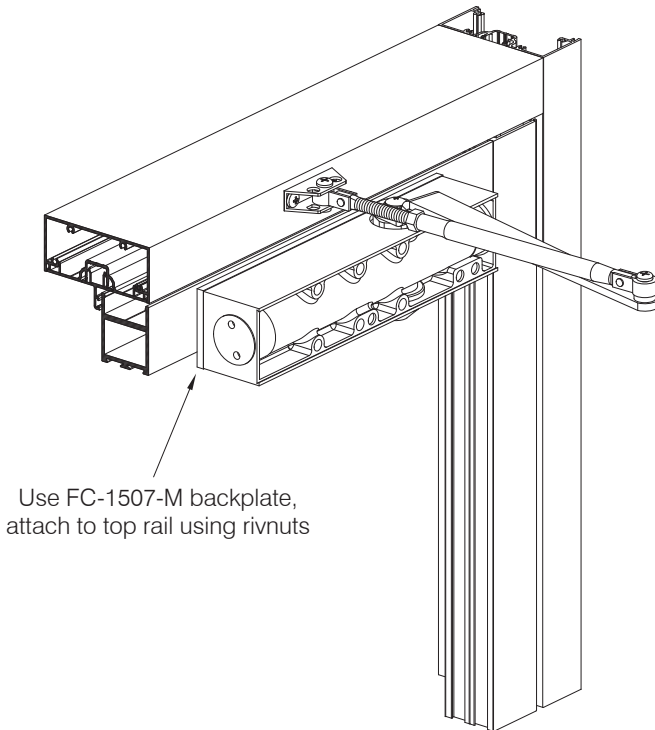

Use FC-1507-M backplate,  
attach to top rail using rivnuts

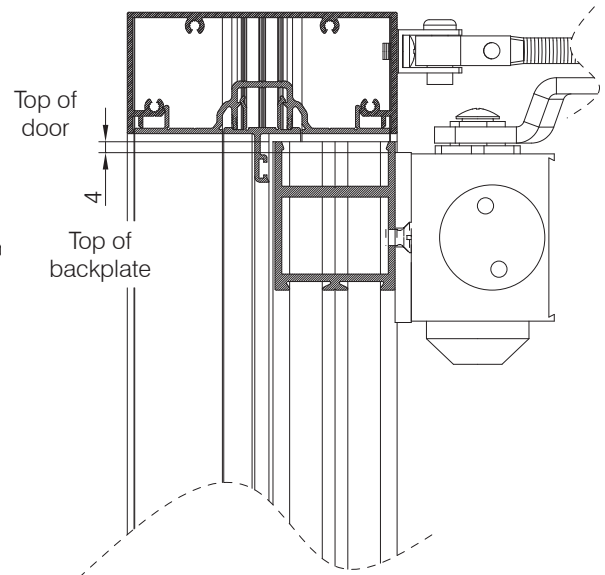

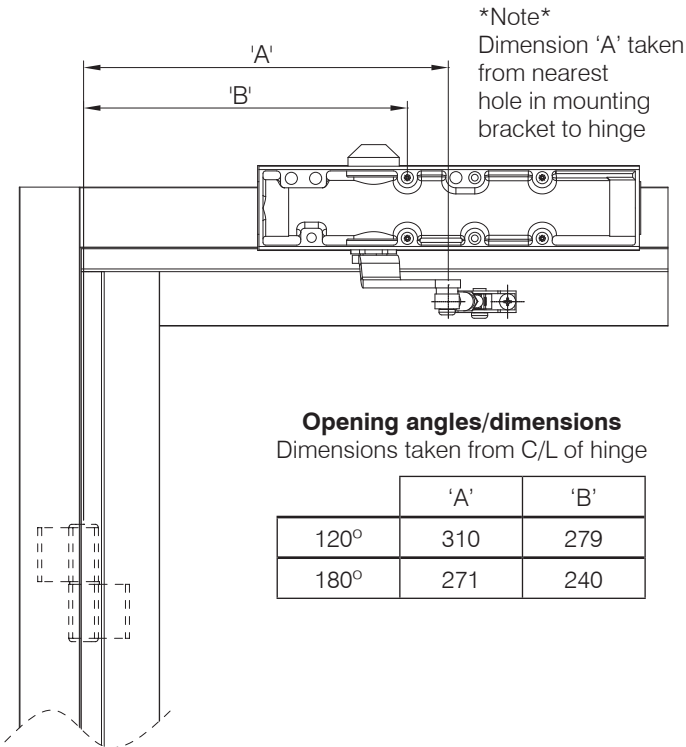

**POSITION OF ARMS AND INDEX SETTINGS**

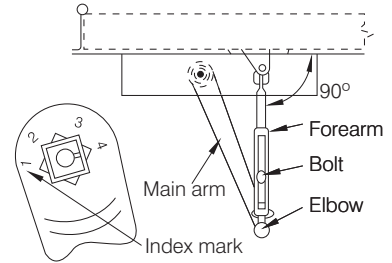

Left hand door. Use index mark 1

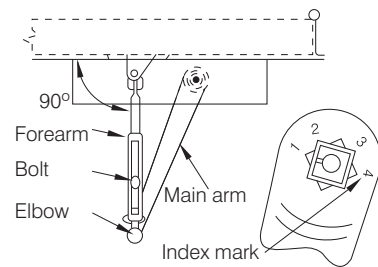

Right hand door. Use index mark 4

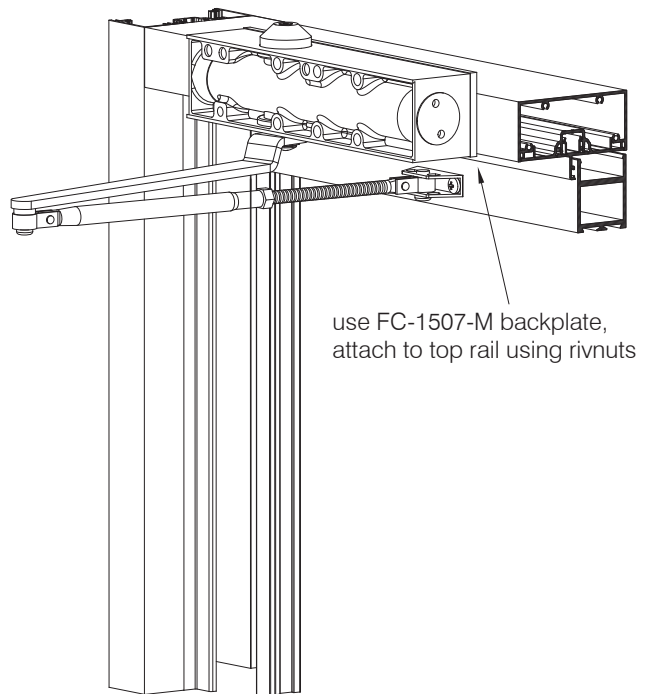
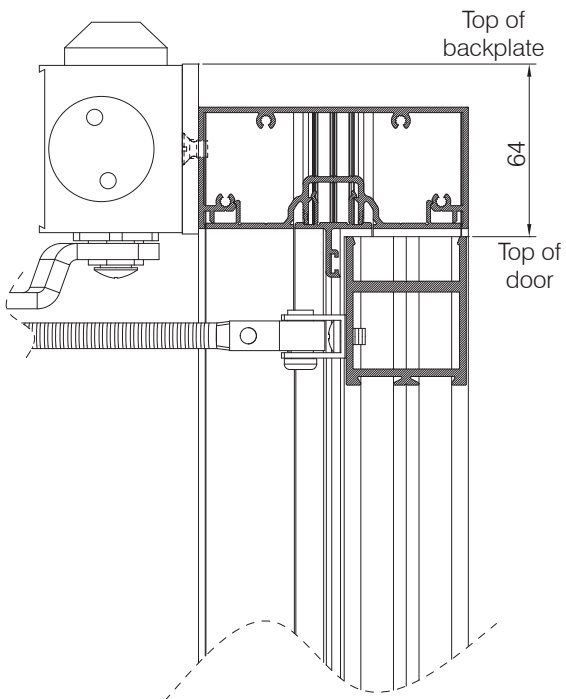

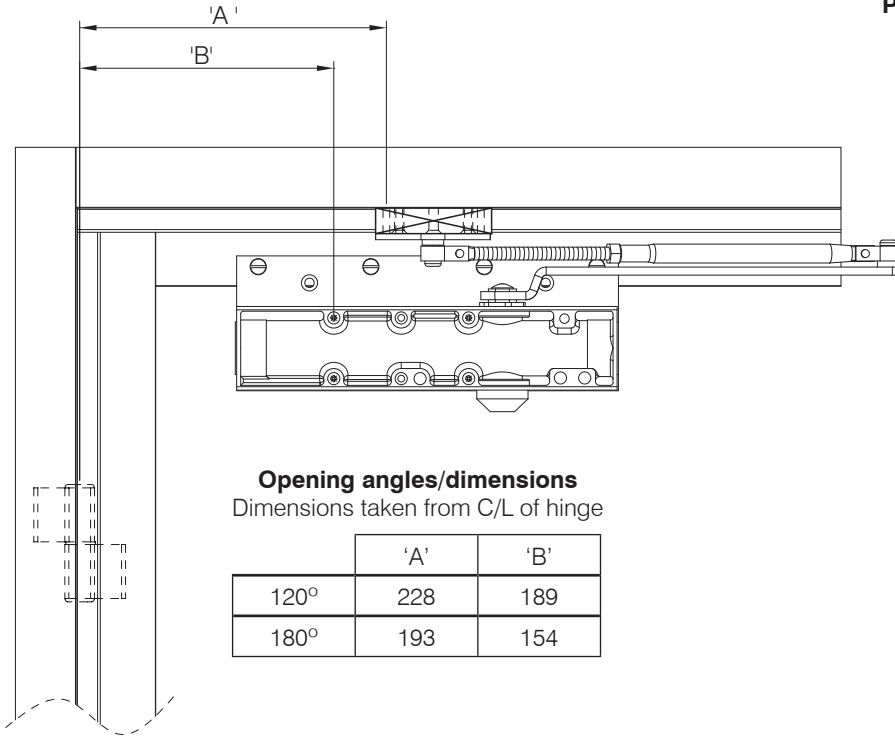

**Opening angles/dimensions**  
Dimensions taken from C/L of hinge

	'A'	'B'
120°	228	189
180°	193	154

**POSITION OF ARMS AND INDEX SETTINGS**

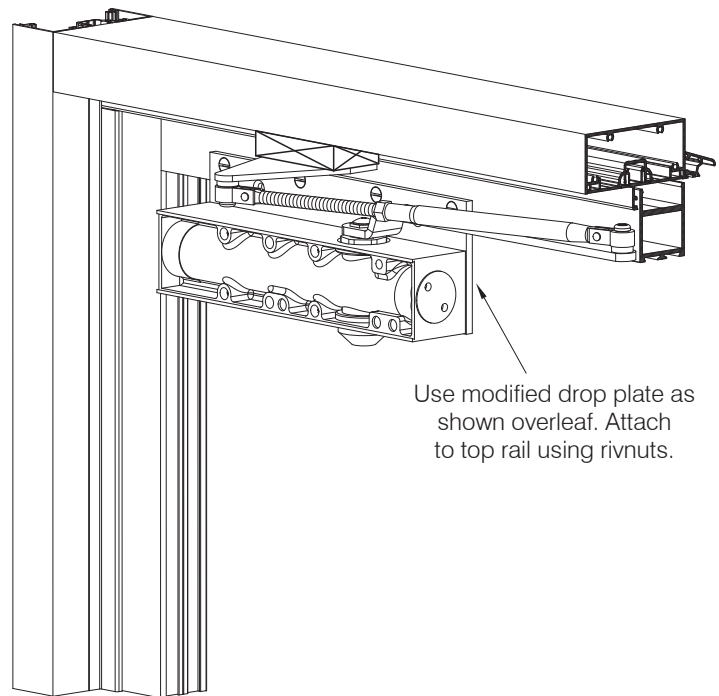
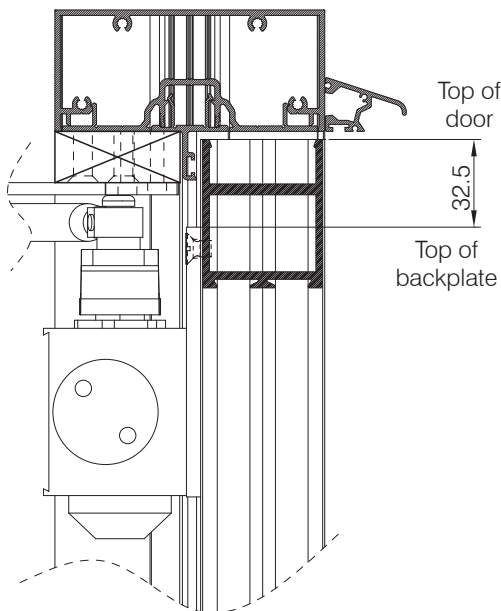
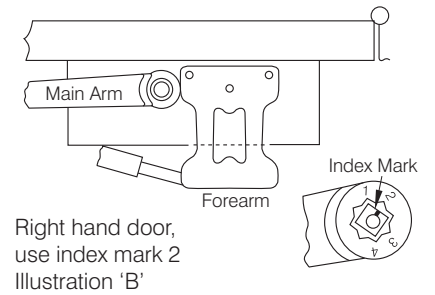
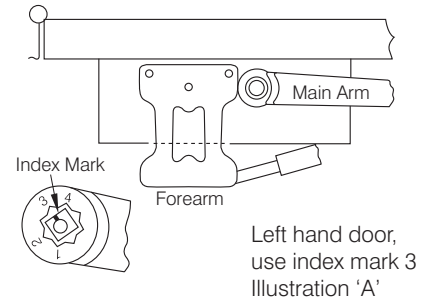

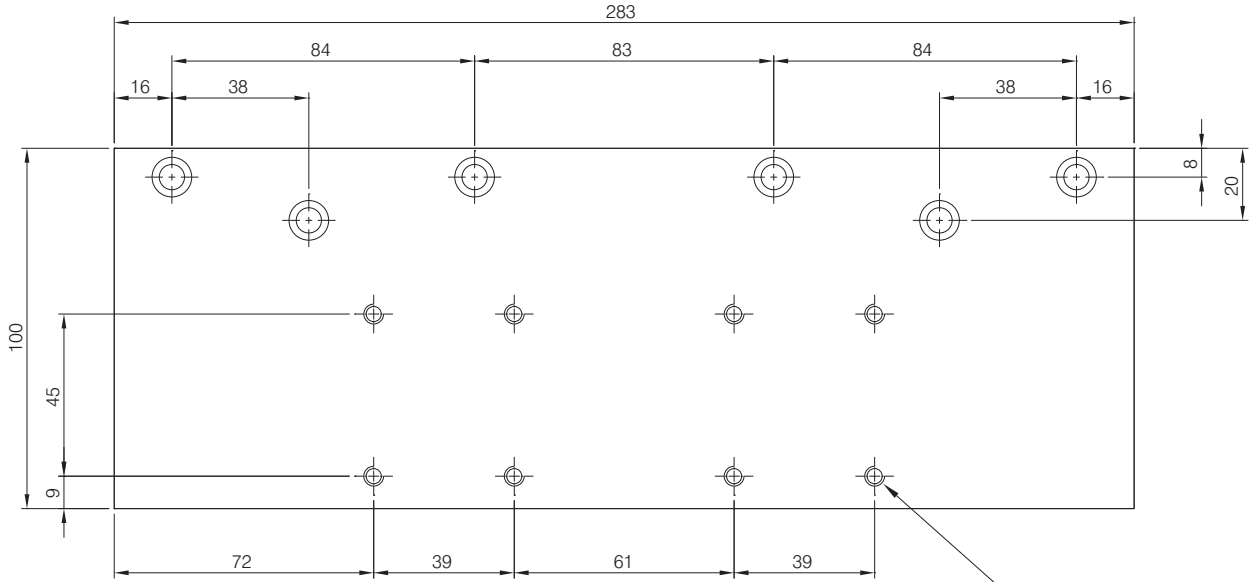

**FC-1507-AL**

Backplate for use with FC1500 series surface closers on parallel arm installation

8 x M5 tapped holes. Typ.

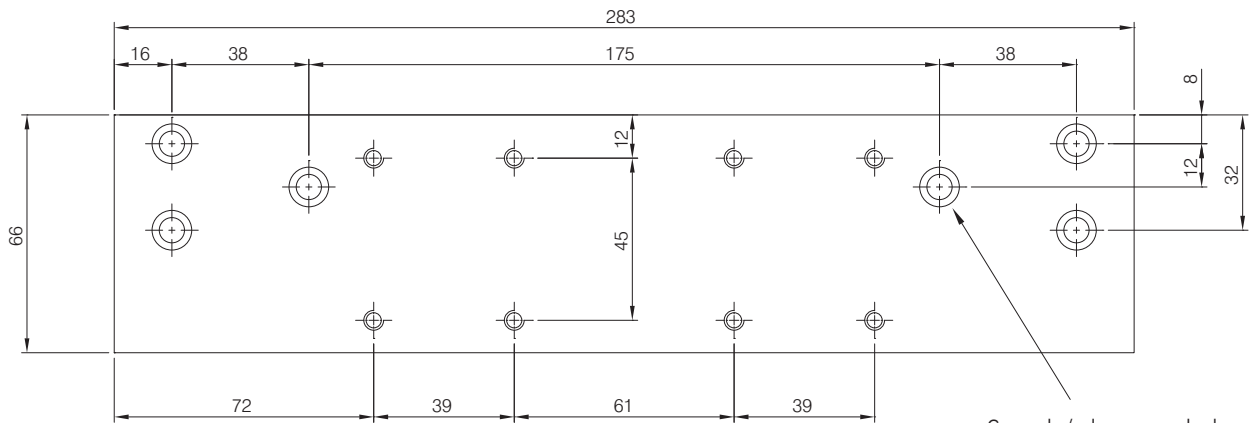

**FC-1507-AL-MOD**

Backplate for use with FC1500 series surface closers on standard and top jamb installation

6 x csk / clearance holes to suit M6 screws. Typ.



The Parkside Group Ltd

The Willow Centre  
17 Willow Lane, Mitcham, Surrey, CR4 4NX  
Tel: 020-8685 9685 Fax: 020-8646 5096  
Email: axim@parksidegroup.co.uk  
Web Site: www.axim.co.uk

SCALE NTS @A4

DATE MARCH 2014

For scaled technical or CAD drawings, please contact AXIM.

ISO view not to scale

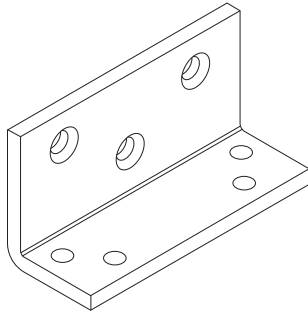

**Material:** Mild steel  
**Finish:** Zinc plating + silver,  
bronze or white PPC

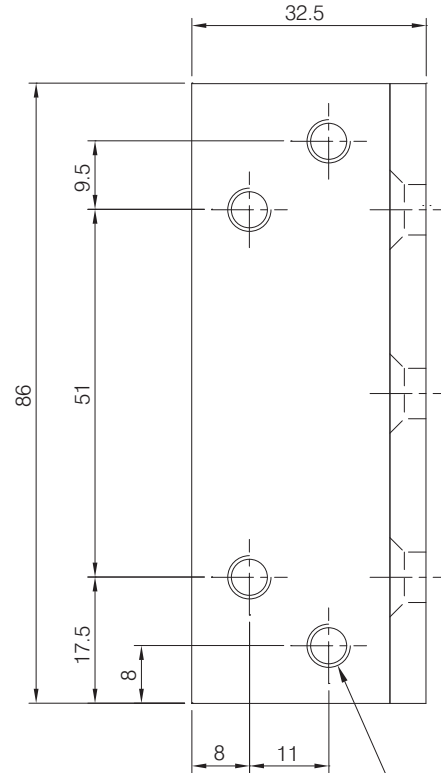

4 x M6 tapped holes

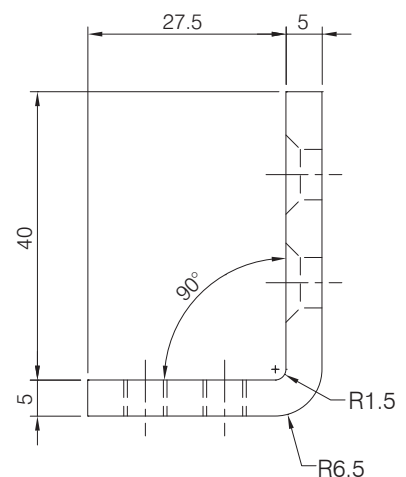
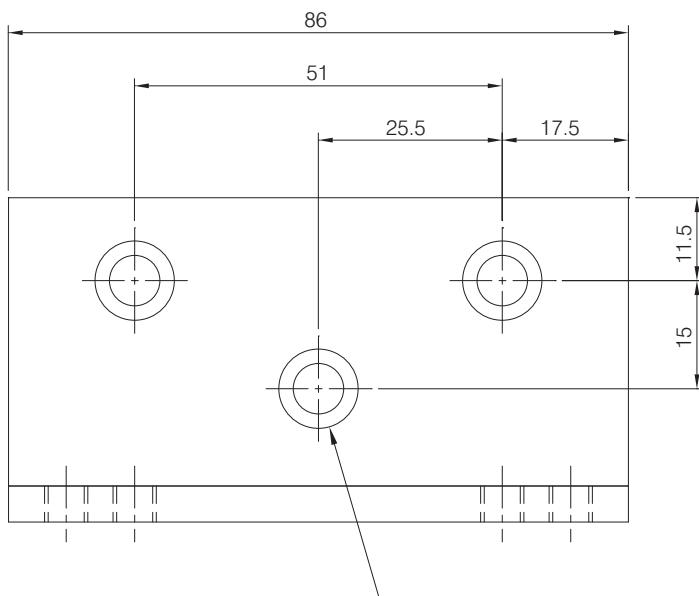

The Parkside Group Ltd

The Willow Centre  
17 Willow Lane, Mitcham, Surrey, CR4 4NX  
Tel: 020-8685 9685 Fax: 020-8646 5096  
Email: axim@parksidegroup.co.uk  
Web Site: www.axim.co.uk

SCALE NTS @A4

DATE MARCH 2014

For scaled technical or CAD drawings,  
please contact AXIM.

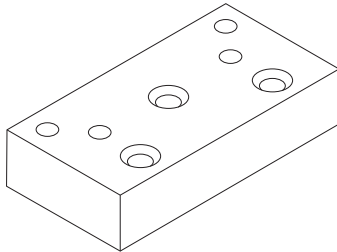

ISO view not to scale

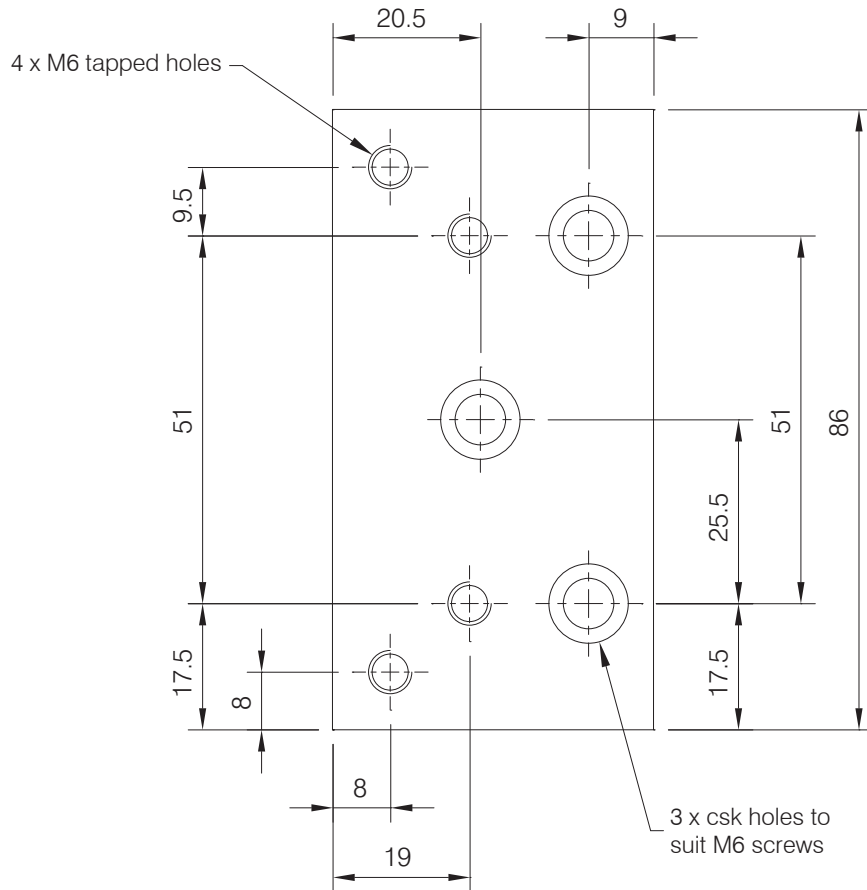
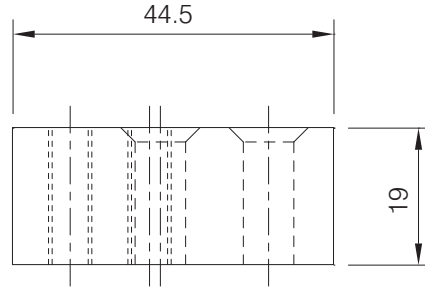

**Material:** Aluminium  
**Finish:** Mill finish



**The Parkside Group Ltd**

The Willow Centre  
17 Willow Lane, Mitcham, Surrey, CR4 4NX  
Tel: 020-8685 9685 Fax: 020-8646 5096  
Email: axim@parksidegroup.co.uk  
Web Site: www.axim.co.uk

SCALE	NTS @A4
DATE	MARCH 2014
For scaled technical or CAD drawings, please contact AXIM.	

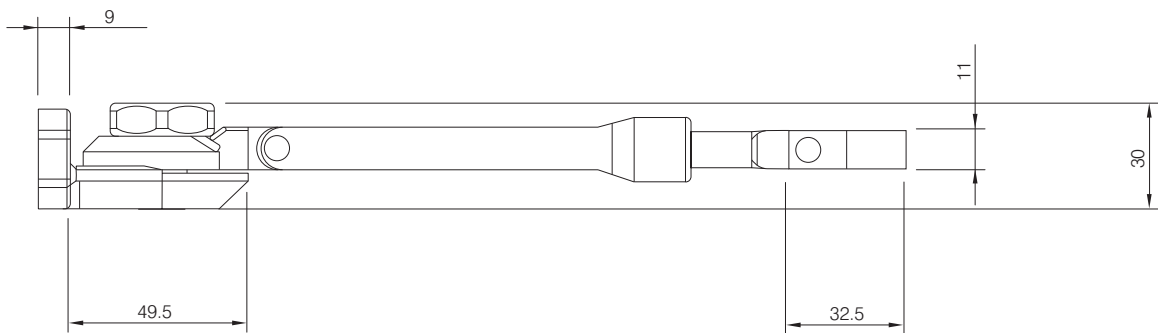
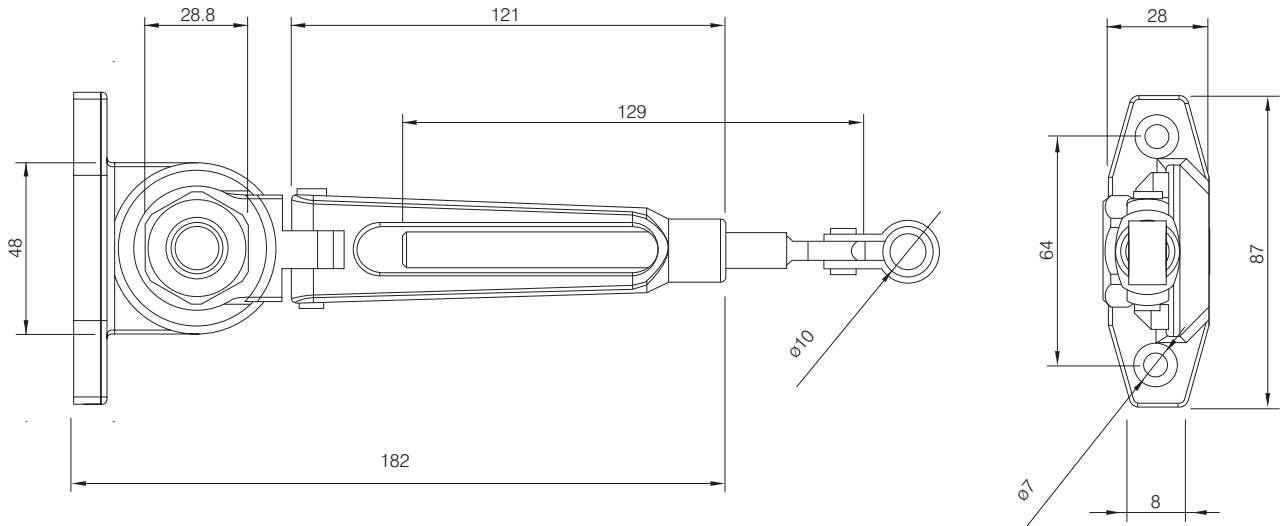

The Parkside Group Ltd

The Willow Centre  
17 Willow Lane, Mitcham, Surrey, CR4 4NX  
Tel: 020-8685 9685 Fax: 020-8646 5096  
Email: [axim@parksidegroup.co.uk](mailto:axim@parksidegroup.co.uk)  
Web Site: [www.axim.co.uk](http://www.axim.co.uk)

SCALE NTS @A4

DATE MARCH 2014

For scaled technical or CAD drawings,  
please contact AXIM.



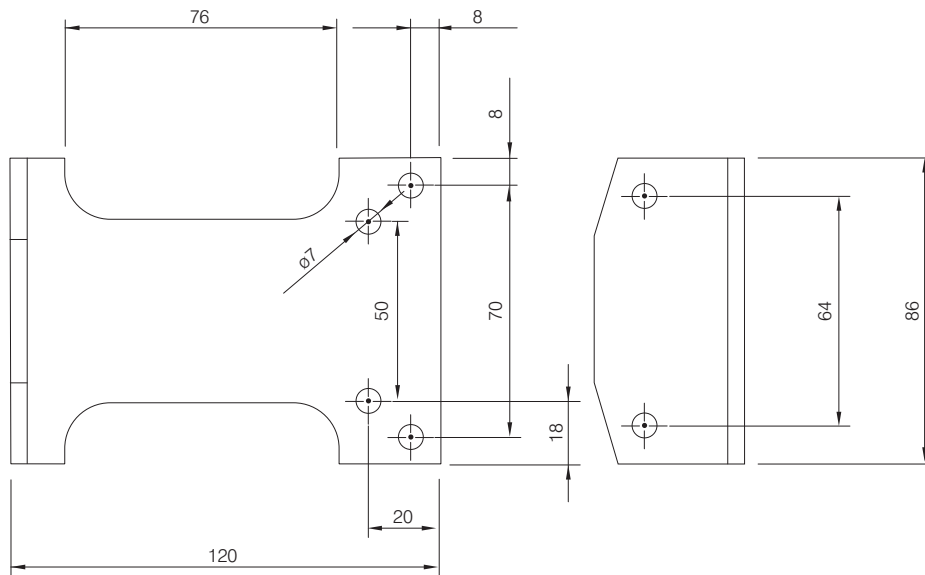
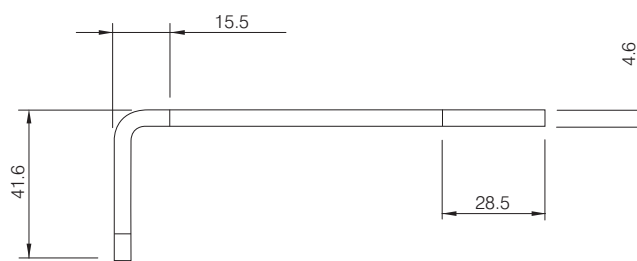
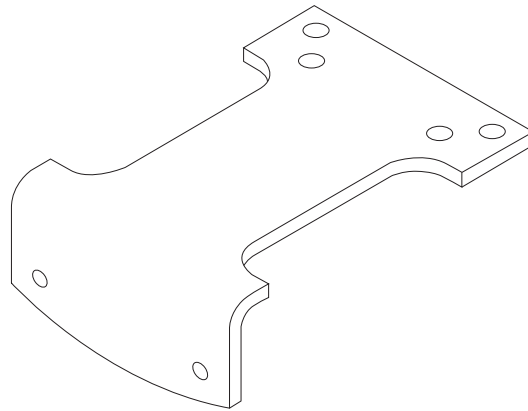

**The Parkside Group Ltd**

The Willow Centre  
 17 Willow Lane, Mitcham, Surrey, CR4 4NX  
 Tel: 020-8685 9685 Fax: 020-8646 5096  
 Email: axim@parksidegroup.co.uk  
 Web Site: www.axim.co.uk

SCALE	NTS @A4
DATE	MARCH 2014
For scaled technical or CAD drawings, please contact AXIM.	

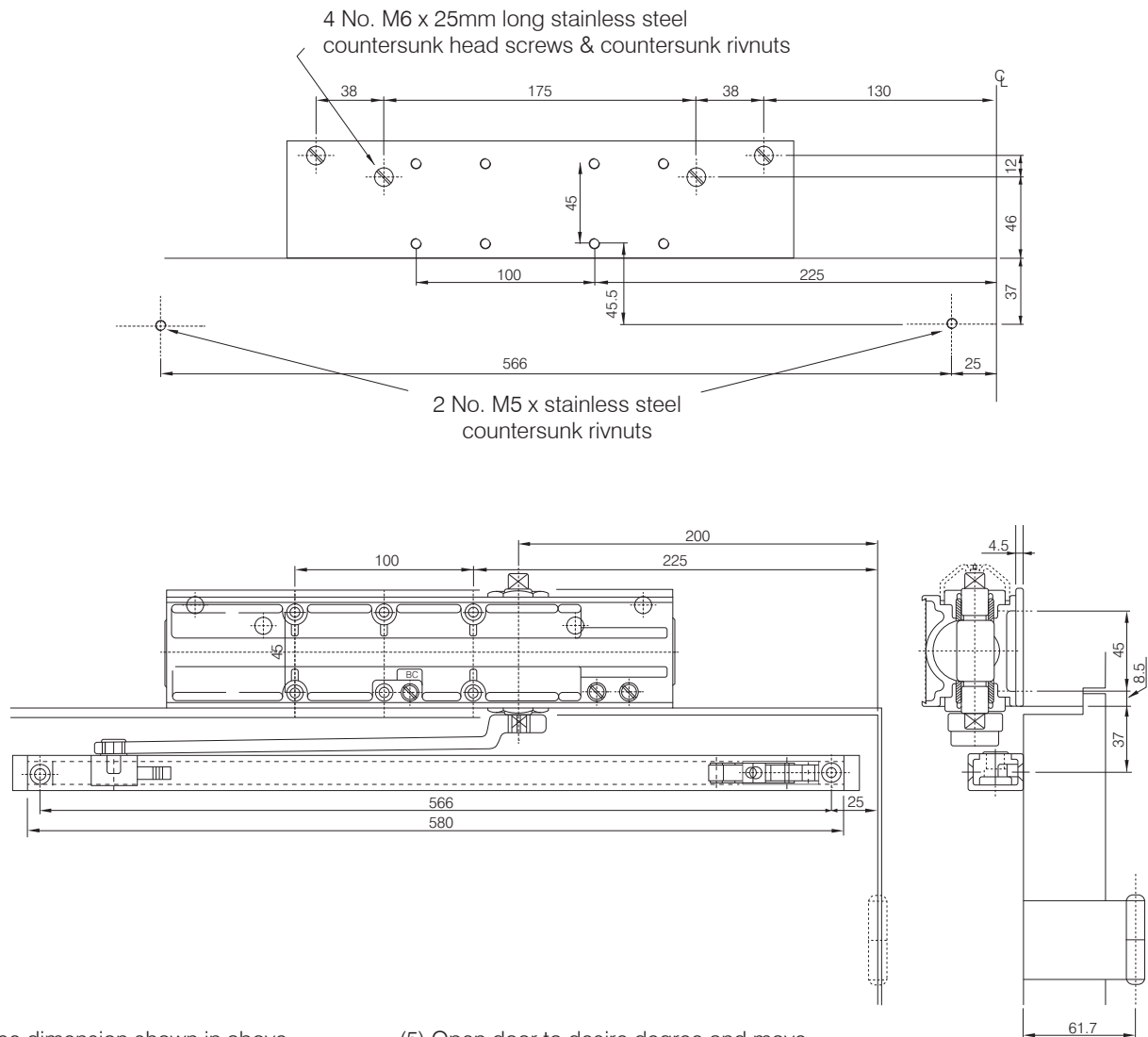

- (1) Use dimension shown in above template to mark six holes on door for door closer and two holes for sliding channel.
- (2) Drill holes in door for 4 - #10 wood screw or drill and tape for 4--M5 x 0.8 (10 x 24) machine screw.
- (3) Drill holes in frame for 2 - #10 wood screw or drill and tape for 2--M5 x 0.8 (10 x 24) machine screw.
- (4) Mount closer and sliding channel, place arm on shaft about 55° from parallel position (as drawing), force arm to parallel position and use ⑤ screw to attached arm & ④ sliding block.

- (5) Open door to desire degree and move the hold open device to be in touch with the sliding block. Tighten the ② adjustment screw.

- (6) For adjusting hold-open force, pls adjust the ③ nut -- clockwise for increasing force & counterclockwise for decreasing. (③ nut can't be adjusted over 2 turns.)

Note: If hold open function is not necessary, please don't install the 'hold open device' into channel.

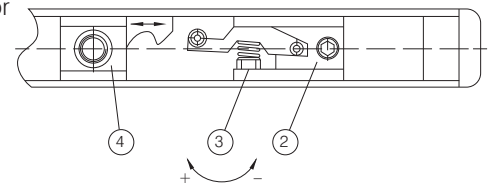

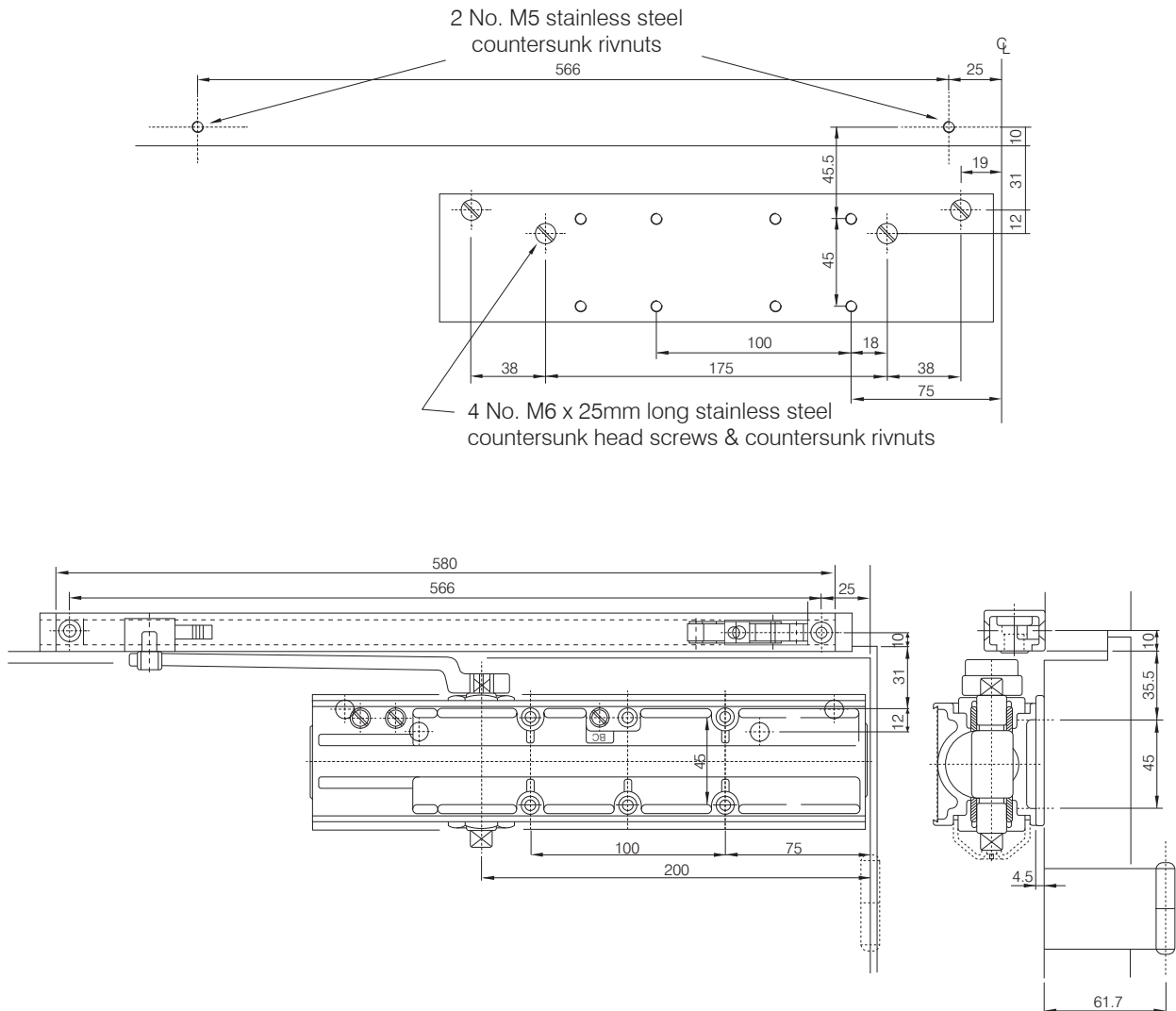

- (1) Use dimension shown in above template to mark six holes on door for door closer and two holes for sliding channel.
- (2) Drill holes in door for 4 - #10 wood screw or drill and tape for 4--M5 x 0.8 (10 x 24) machine screw.
- (3) Drill holes in frame for 2 - #10 wood screw or drill and tape for 2--M5 x 0.8 (10 x 24) machine screw.
- (4) Mount closer and sliding channel, place arm on shaft about 55° from parallel position (as drawing), force arm to parallel position and use ⑤ screw to attached arm & ④ sliding block.

- (5) Open door to desire degree and move the hold open device to be in touch with the sliding block. Tighten the ② adjustment screw.
- (6) For adjusting hold-open force, pls adjust the ③ nut -- clockwise for increasing force & counterclockwise for decreasing. (③ nut can't be adjusted over 2 turns.)

Note: If hold open function is not necessary, please don't install the 'hold open device' into channel.

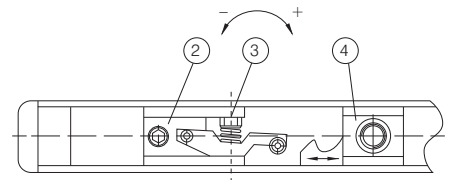

**UNIVERSAL SURFACE MOUNTED DOOR  
CLOSER**

Reversible for left or right hand doors. Die-cast aluminium housing with a hardened steel rack and pinion mechanism. One size unit for two strengths, 2 & 3. For strengths 1, 4 & 5 the compatible 2000 series is recommended.

**ADJUSTMENT**

Two independent valves providing hydraulic control from 180° of closing sweep and 15° of latching. Fully adjustable after installation.

**AVAILABLE IN THREE FINISHES**

Aluminium.  
Dark bronze.  
Gold.  
Other colours available on special request.

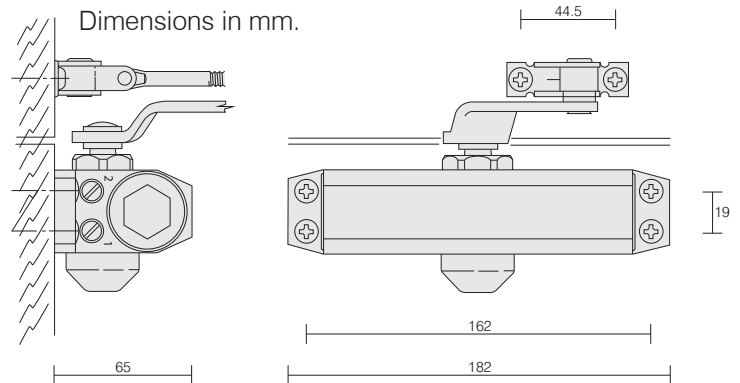

**CLOSING RANGE AND ADJUSTMENT**

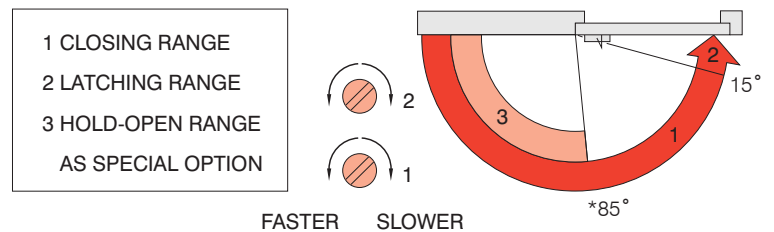

**MODEL SELECTION TABLE (MAXIMUM DOOR WIDTH DIMENSION IN mm)**

SIZE NO.	105° OPENING ANGLE		Closing Force Nm (kgm.f)	185° OPENING ANGLE		Closing Force Nm (kgm.f)
	INTERIOR DOOR	EXTERIOR DOOR		INTERIOR DOOR	EXTERIOR DOOR	
2	900	750	19 (1.9)	750	600	14 (1.4)
3	1050	900	23 (2.3)	900	750	19 (1.9)

**ACCESSORIES**

Flat top bracket for installation on door when direct fixing is not possible. Hold-open arm, friction type, adjustable for any degree of retention.

**FLAT DROP BRACKET 517**

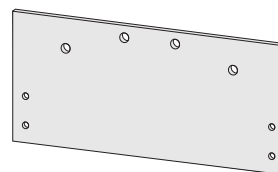

**HOLD-OPEN FOREARM 422**



**SPECIAL ORDER OPTIONS**

\*The Fc30 is available with a 'built-in' hold-open function from 85°.

**GUARANTEE**

AXIM SURFACE MOUNTED CLOSERS AND ACCESSORIES ARE GUARANTEED FOR 30 MONTHS FROM THE DATE OF MANUFACTURE AGAINST DEFECT IN MATERIAL AND WORKMANSHIP. THIS GUARANTEE IS VOID IF THE PRODUCT HAS BEEN INCORRECTLY INSTALLED OR DAMAGED IN USE. CLAIMS FOR DAMAGE INCURRED OR WORK DONE THEREON WILL NOT BE ACCEPTED.

AXIM RESERVE THE RIGHT TO UPDATE ITS PRODUCT SPECIFICATIONS WITHOUT PRIOR NOTICE.



**The Parkside Group Ltd**

The Willow Centre  
17 Willow Lane, Mitcham, Surrey, CR4 4NX  
Tel: 020-8685 9685 Fax: 020-8646 5096  
Email: axim@parksidegroup.co.uk  
Web Site: www.axim.co.uk

SCALE NTS @A4

DATE AUGUST 2017

For scaled technical or CAD drawings, please contact AXIM.

**Standard installation**

Closer mounted on door on pull side

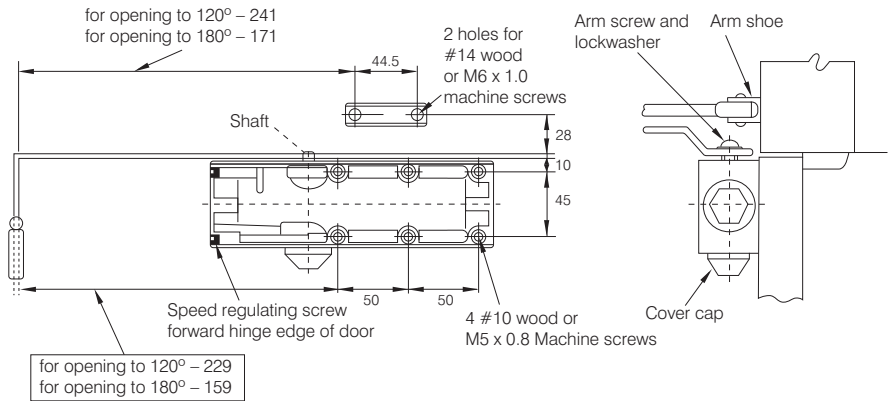
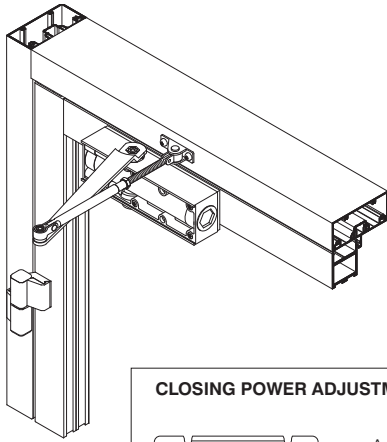

**CLOSING POWER ADJUSTMENT**

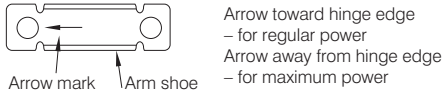

**Right hand door shown**  
Same dimensions apply for left hand door measured from hinge edge

**POSITION OF ARMS AND INDEX SETTINGS**

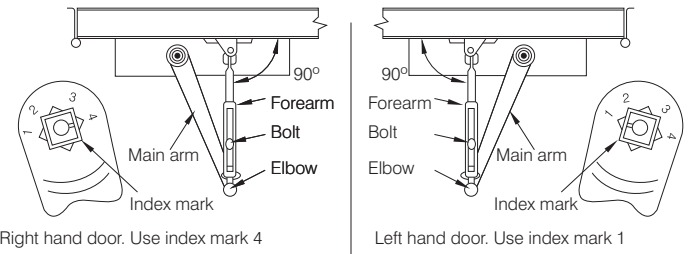

**Top jamb installation**

Closer mounted on top jamb on push side of door.  
Reveals of 70 to 127 requires long top jamb forearms

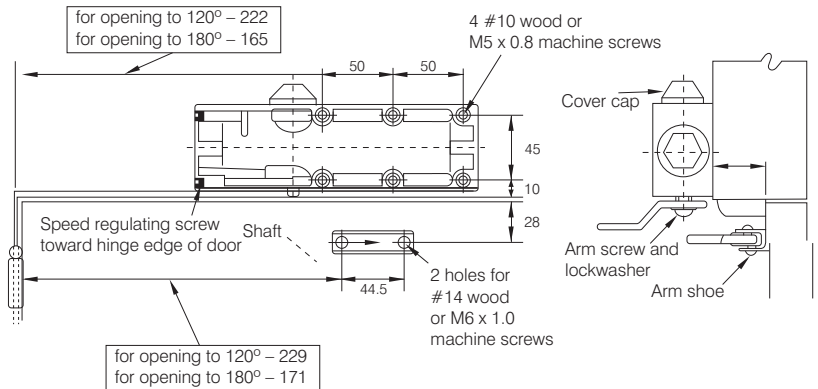
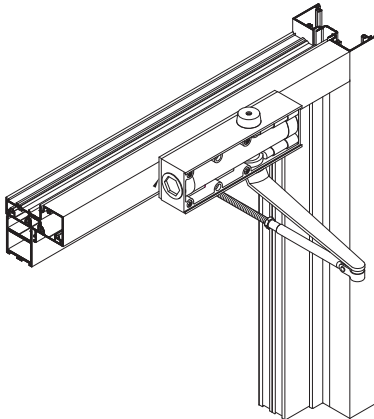

**CLOSING POWER ADJUSTMENT**

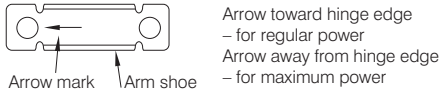

**Left hand door shown**  
Same dimensions apply for right hand door measured from hinge edge

**POSITION OF ARMS AND INDEX SETTINGS**

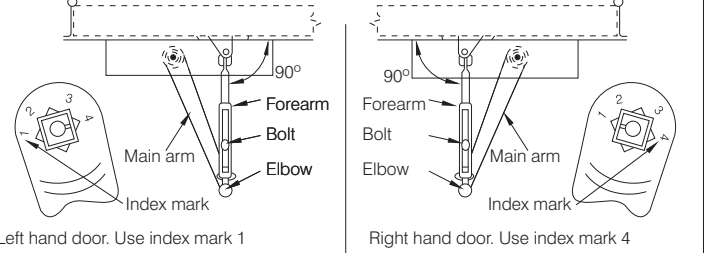

**The Parkside Group Ltd**

The Willow Centre  
17 Willow Lane, Mitcham, Surrey, CR4 4NX  
Tel: 020-8685 9685 Fax: 020-8646 5096  
Email: axim@parksidegroup.co.uk  
Web Site: www.axim.co.uk

SCALE NTS @A4

DATE MARCH 2014

For scaled technical or CAD drawings,  
please contact AXIM.

**Parallel arm installation**

Closer mounted on door on push side

**Left hand door shown**

Same dimensions apply for right hand door measured from hinge edge.

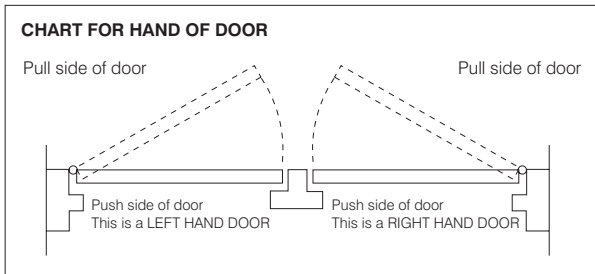
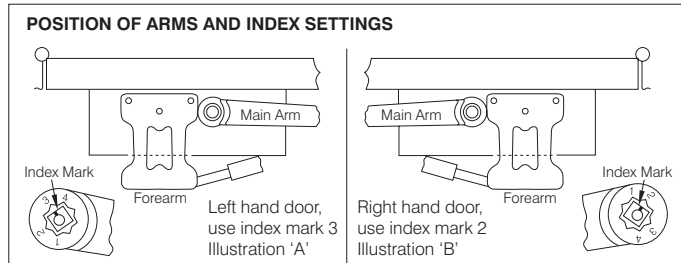
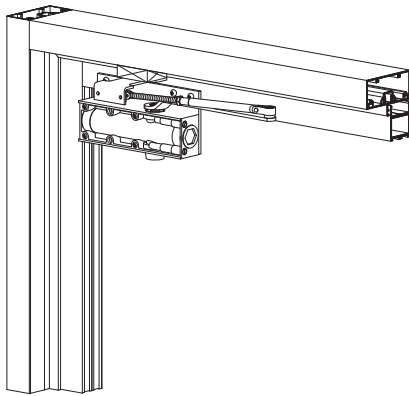
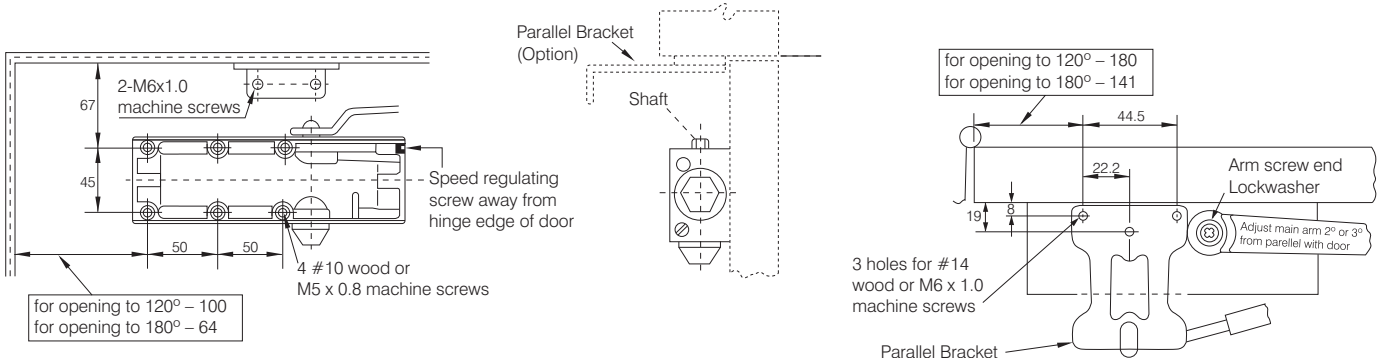

**Instructions**

Step 1

- A. Check hand of door.
- B. Select type of installation.

Step 2

- A. See instructions for installation you have selected.
- B. Follow instructions for correct application and adjustment.

Step 3

- A. Apply closer body and forearm (or parallel bracket and forearm) to door and frame as shown.
- B. Place main arm on shaft at proper index mark as shown and tighten arm screw with lockwasher securely.
- C. Adjust length of forearm as shown and attach to main arm at elbow and tighten locknut bolt.

Step 4

Fixing cover cap on shaft at unused side and insert rubber plug into one of unused fixing hole on body then slide in the Faceplate.

Step 5

Door closing and latching speeds are controlled by #1, #2 speed regulating screw separately.

- A. Clockwise turns slow the Speed.
- B. Counterclockwise turns increase the speed.

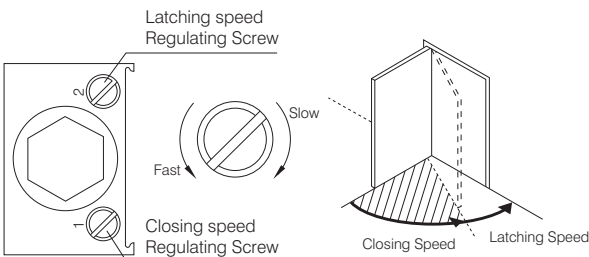

**The Parkside Group Ltd**

The Willow Centre  
17 Willow Lane, Mitcham, Surrey, CR4 4NX  
Tel: 020-8685 9685 Fax: 020-8646 5096  
Email: axim@parksidegroup.co.uk  
Web Site: www.axim.co.uk

SCALE	NTS @A4
DATE	MARCH 2014
For scaled technical or CAD drawings, please contact AXIM.	

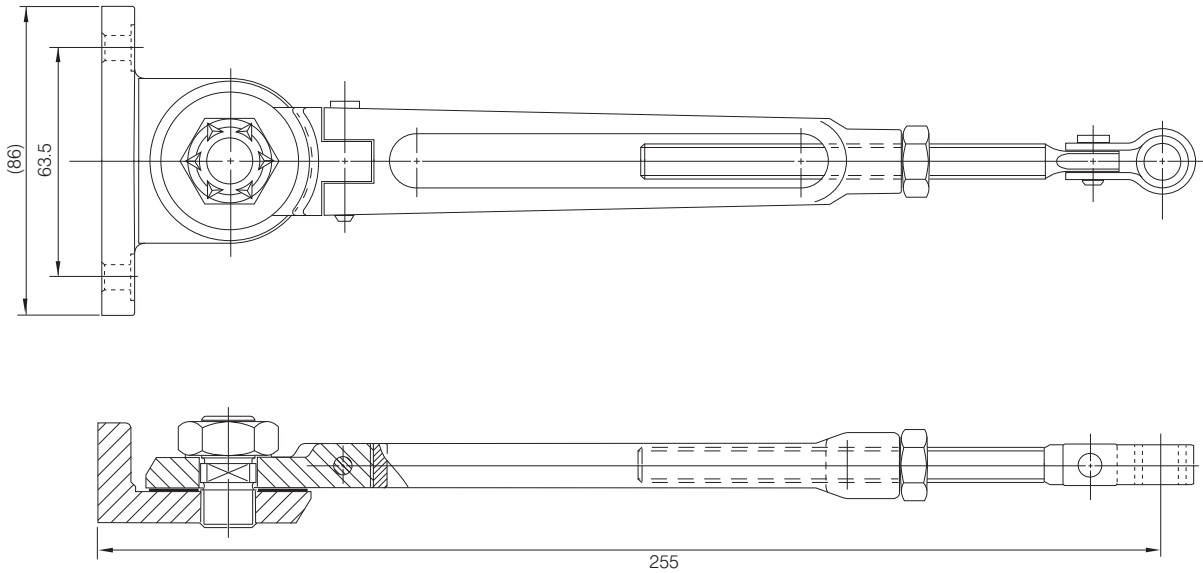

The Parkside Group Ltd

The Willow Centre  
17 Willow Lane, Mitcham, Surrey, CR4 4NX  
Tel: 020-8685 9685 Fax: 020-8646 5096  
Email: axim@parksidegroup.co.uk  
Web Site: www.axim.co.uk

SCALE	NTS @A4
DATE	MARCH 2014

For scaled technical or CAD drawings,  
please contact AXIM.

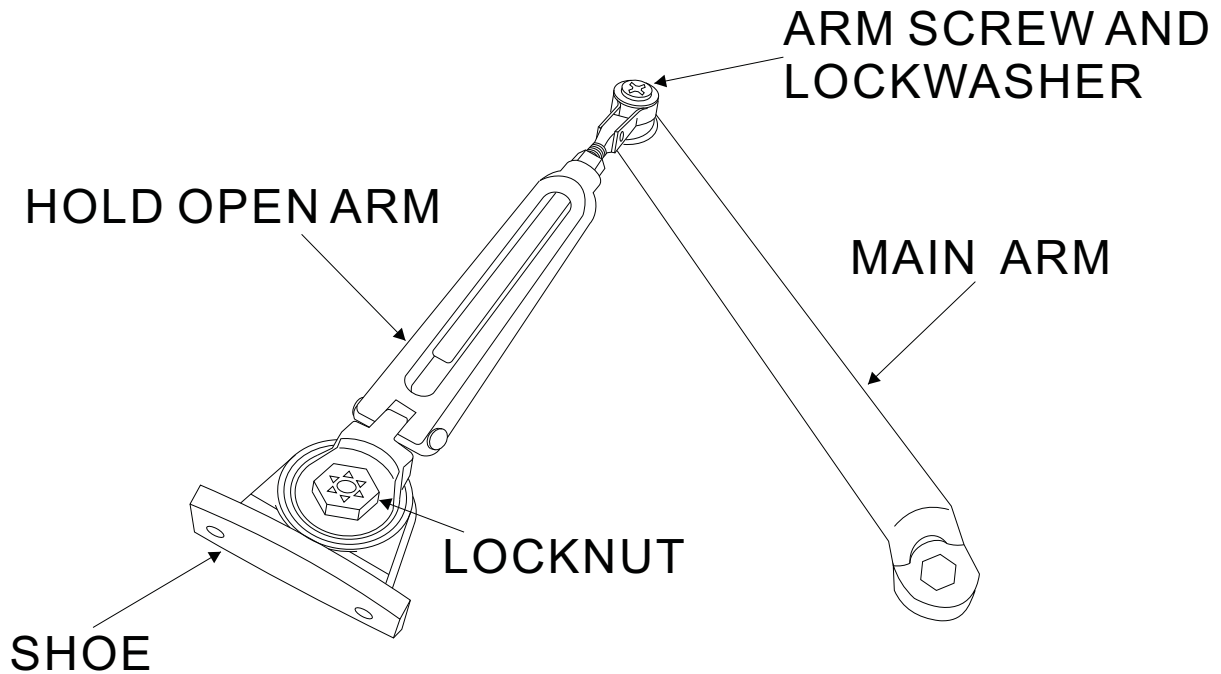

The Parkside Group Ltd

The Willow Centre  
17 Willow Lane, Mitcham, Surrey, CR4 4NX  
Tel: 020-8685 9685 Fax: 020-8646 5096  
Email: axim@parksidegroup.co.uk  
Web Site: www.axim.co.uk

SCALE NTS @A4

DATE MARCH 2014

For scaled technical or CAD drawings,  
please contact AXIM.



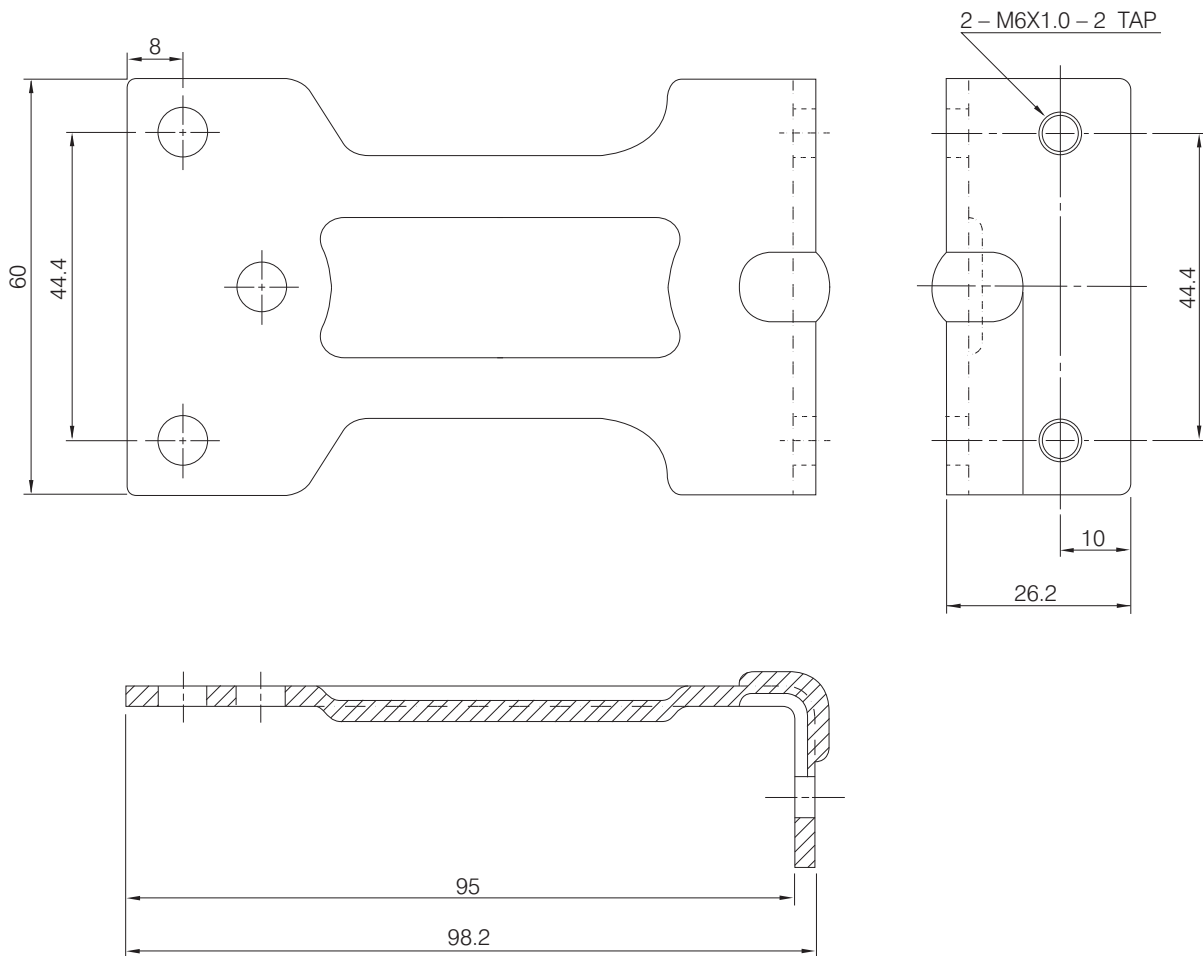

The Parkside Group Ltd

The Willow Centre  
17 Willow Lane, Mitcham, Surrey, CR4 4NX  
Tel: 020-8685 9685 Fax: 020-8646 5096  
Email: [axim@parksidegroup.co.uk](mailto:axim@parksidegroup.co.uk)  
Web Site: [www.axim.co.uk](http://www.axim.co.uk)

SCALE	NTS @A4
DATE	MARCH 2014

For scaled technical or CAD drawings,  
please contact AXIM.

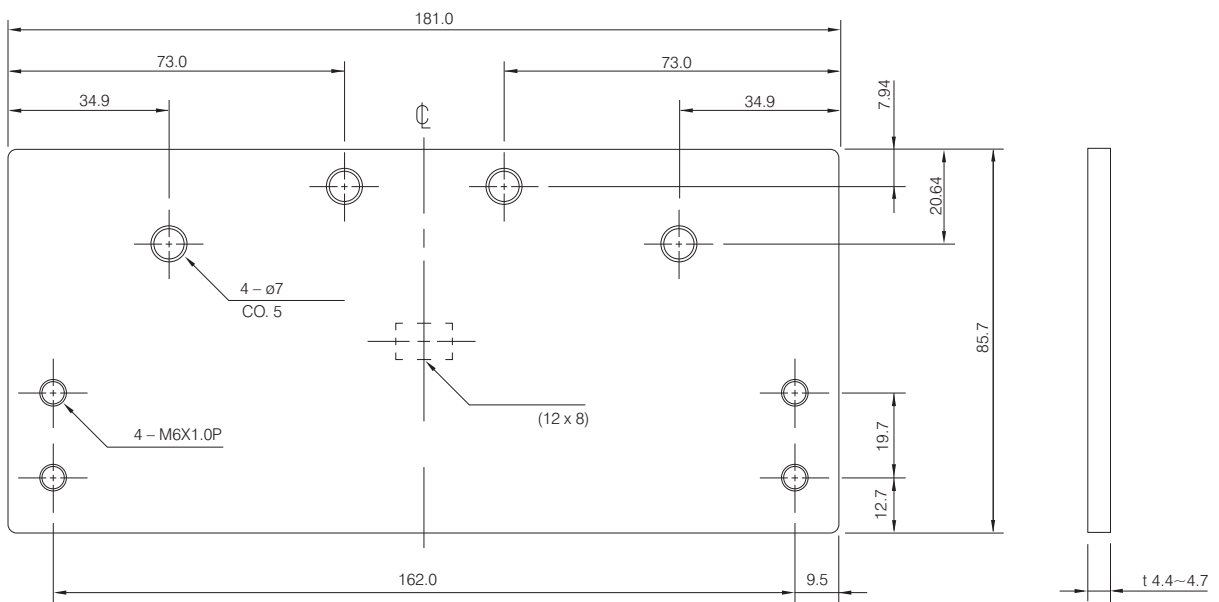

The Parkside Group Ltd

The Willow Centre  
17 Willow Lane, Mitcham, Surrey, CR4 4NX  
Tel: 020-8685 9685 Fax: 020-8646 5096  
Email: [axim@parksidegroup.co.uk](mailto:axim@parksidegroup.co.uk)  
Web Site: [www.axim.co.uk](http://www.axim.co.uk)

SCALE NTS @A4

DATE MARCH 2014

For scaled technical or CAD drawings,  
please contact AXIM.

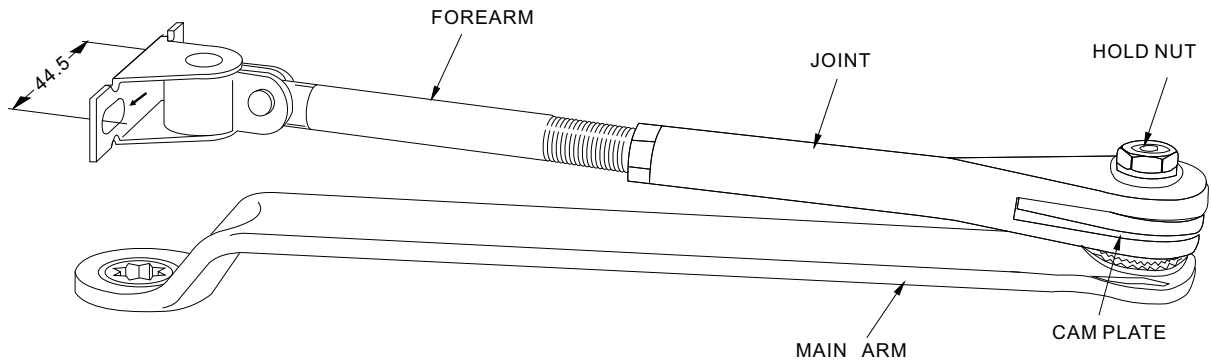

**The Parkside Group Ltd**

The Willow Centre  
 17 Willow Lane, Mitcham, Surrey, CR4 4NX  
 Tel: 020-8685 9685 Fax: 020-8646 5096  
 Email: axim@parksidegroup.co.uk  
 Web Site: www.axim.co.uk

SCALE	NTS @A4
DATE	MARCH 2014

For scaled technical or CAD drawings,  
 please contact AXIM.

**Parallel arm installation**

Closer mounted on door on push side

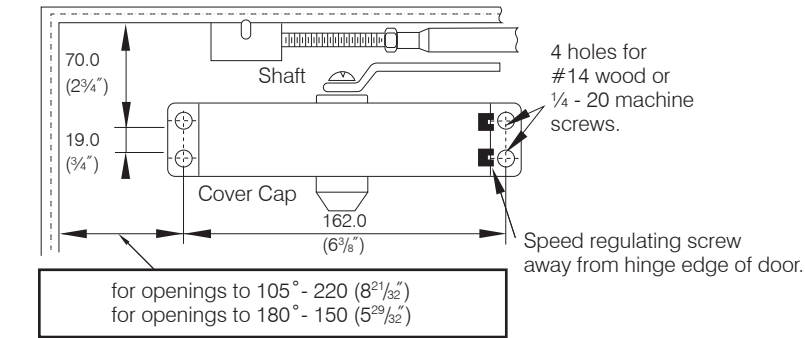

for openings to 105° - 220 (8<sup>21</sup>/<sub>32</sub>)  
for openings to 180° - 150 (5<sup>29</sup>/<sub>32</sub>)

for openings to 105° - 230 (9<sup>1</sup>/<sub>16</sub>)  
for openings to 180° - 160 (6<sup>19</sup>/<sub>64</sub>)

LEFT HAND DOOR shown.  
Same dimensions apply for right hand door  
measured from hinge edge.

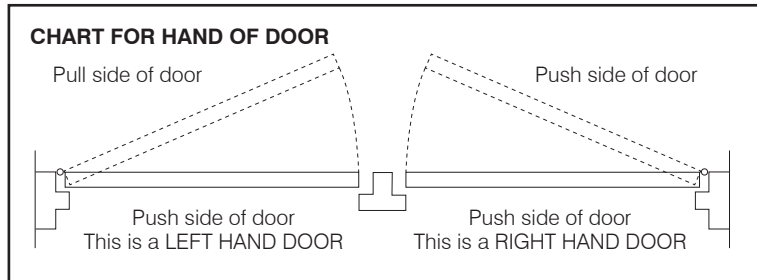
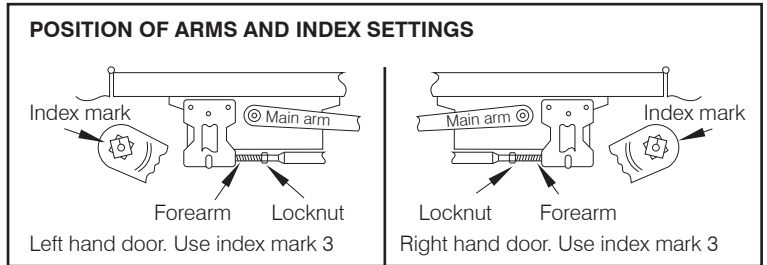
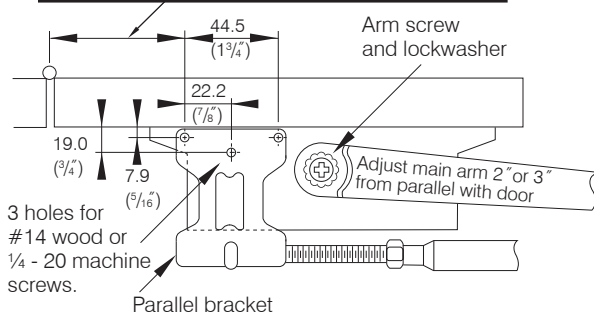
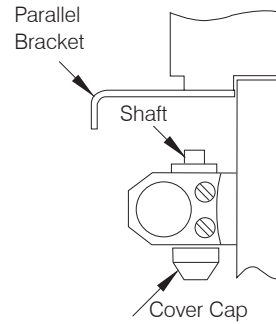

**Instructions**

- Step 1**  
A. Check hand of door.  
B. Select type of installation.
- Step 2**  
A. See instructions for installation you have selected.  
B. Follow instructions for correct application and adjustment.
- Step 3**  
A. Apply closer body and forearm (or parallel bracket and forearm) to door and frame as shown.  
B. Place main arm on shaft at proper index mark as shown and tighten arm screw with lockwasher securely.  
C. Adjust length of forearm as shown and attach to main arm at elbow and tighten locknut.
- Step 4**  
Snap cover cap over shaft at unused side.
- Step 5**  
Door closing and latching speeds are controlled by #1, #2 speed.  
Regulating screw separately.  
A. Clockwise turns slow the speed.  
B. Counterclockwise turns increase the speed.

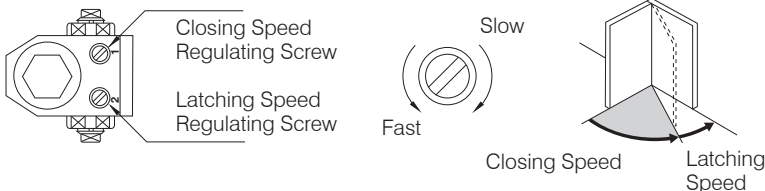

**The Parkside Group Ltd**

The Willow Centre  
17 Willow Lane, Mitcham, Surrey, CR4 4NX  
Tel: 020-8685 9685 Fax: 020-8646 5096  
Email: axim@parksidegroup.co.uk  
Web Site: www.axim.co.uk

SCALE	NTS @A4
DATE	MARCH 2014
For scaled technical or CAD drawings, please contact AXIM.	

**Standard installation**

Closer mounted on door pull side

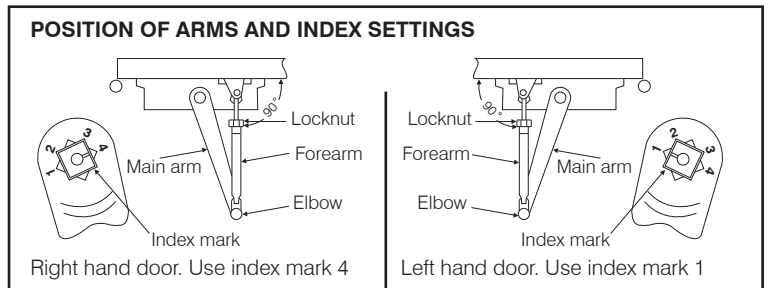
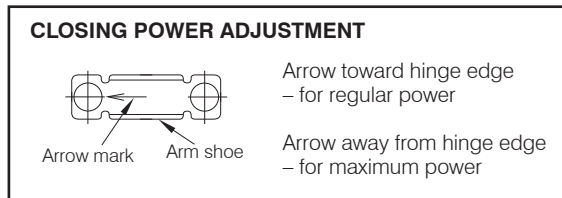
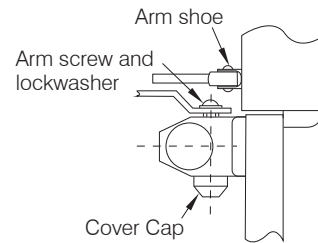
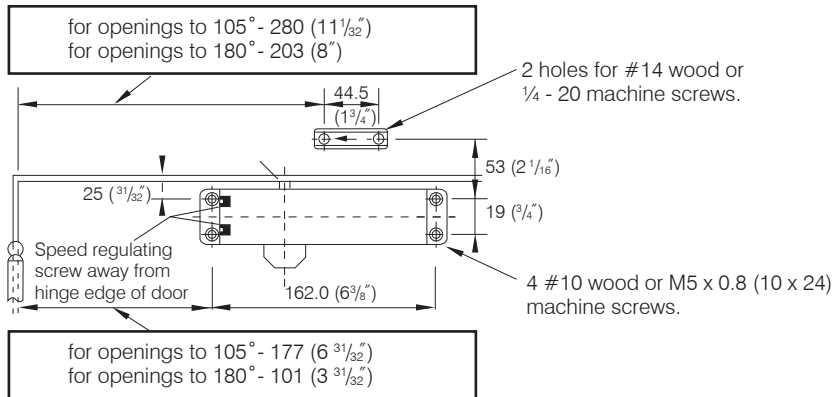

**Right hand door shown**

Same dimensions apply for left hand door measured from hinge edge.

**Top jamb installation**

Closer mounted on top jamb on push side of door.  
Reveals of 70 (2 3/4") to 127 (5") requires long top jamb forearms.

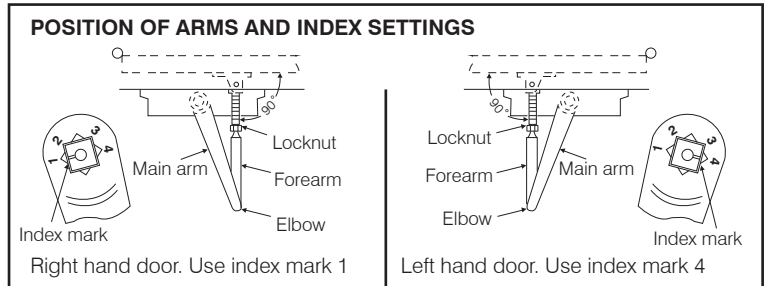
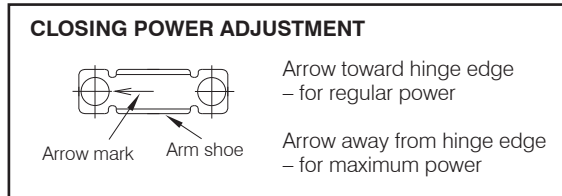
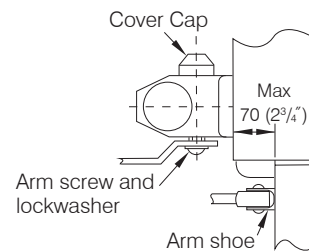
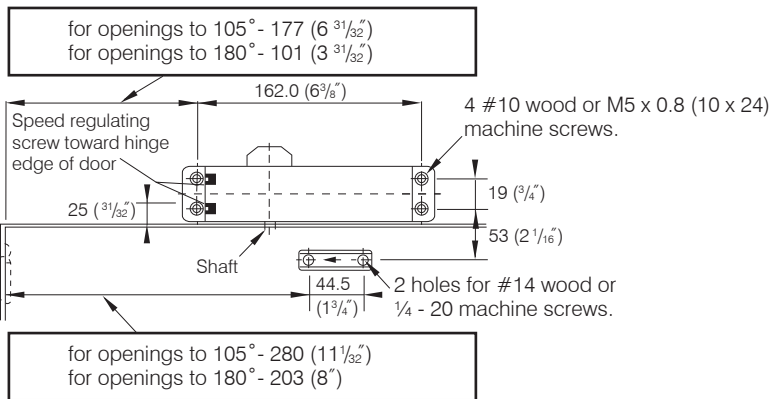

**Left hand door shown**

Same dimensions apply for right hand door measured from hinge edge.



The Parkside Group Ltd

The Willow Centre  
17 Willow Lane, Mitcham, Surrey, CR4 4NX  
Tel: 020-8685 9685 Fax: 020-8646 5096  
Email: axim@parksidegroup.co.uk  
Web Site: www.axim.co.uk

SCALE	NTS @A4
DATE	MARCH 2014
For scaled technical or CAD drawings, please contact AXIM.	



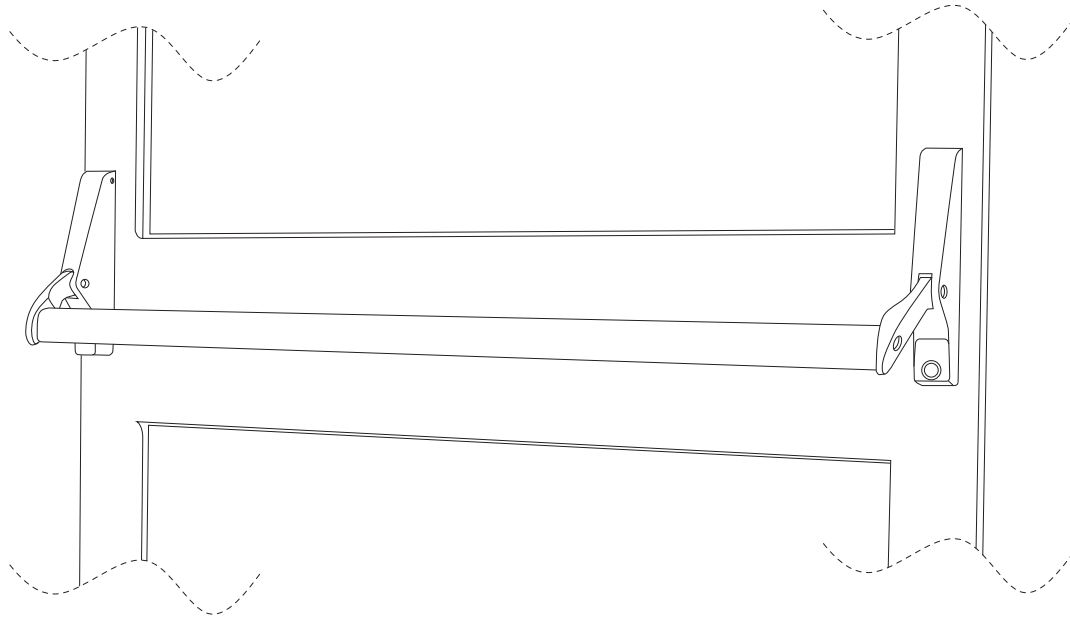

**CONCEALED ROD, PANIC EXIT DEVICE**

Heavy duty lever springs for durable operation of lever arms.  
Internal mechanism manufactured from stainless and plated steel.  
8.5mm Diameter steel operating rods 16mm bolt throw.  
Bolt length adjustable ensuring correct alignment.  
Standard model suitable for doors 2135mm high x 1155mm wide.  
300mm and 600mm coupling rods available for tall doors and 1220mm long crossbars for extra wide doors. Cross bars can be cut to suit exact width requirements.  
Available with standard mortice rim cylinder, handle and mounting pad allowing operation from outside.  
Permanent latch retention by either cylinder key from outside or concealed pins under levers.  
Anodised crossbars in:-  
Silver Satin, Dark Bronze & Black.  
Housings and lever arms stoved, abrasive resistant finish to match anodised finishes.  
Easy to follow instructions and full size templates supplied with every unit.

**SUGGESTED SPECIFICATION**

Concealed vertical rod panic exit devices shall be AXIM Series 7085.  
Door shall be latched at top and bottom except during operation cycle or when held open using key or concealed dogging pin.  
Exit device housings shall not exceed 118 x 186mm projection.  
All mounting screws shall be concealed.  
Heavy duty springs (to raise the crossbar) shall be used on each housing for durability.

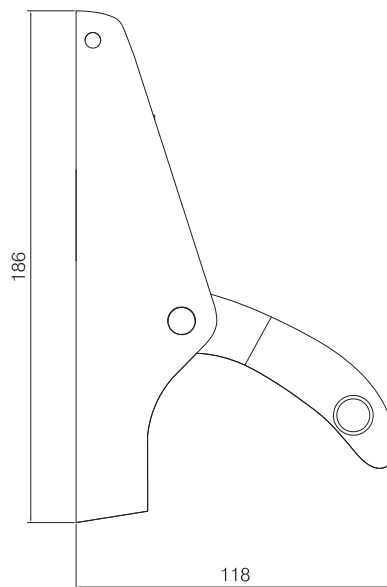

**ACCESSORIES**

Rim cylinder for access from outside. (2 keys.)  
**Product Code:-**  
**RC-785-AL** - 46mm DOOR STILE - Silver  
**RC-785-AL-S** - 46mm DOOR STILE - Silver  
**RC-785-DU** - 46mm DOOR STILE - Dark Bronze  
**RC-785-BK** - 46mm DOOR STILE - Black

Mounting pad for fixing rim cylinder.

**Product codes:-**  
**MP-786-AL** - 46mm DOOR STILE - Silver  
**MP-786-DU** - 46mm DOOR STILE - Dark Bronze  
**MP-786-BK** - 46mm DOOR STILE - Black  
**MP-788-AL** - 49mm DOOR STILE - Silver  
**MP-790-AL** - 54mm DOOR STILE - Silver  
**MP-792-AL** - 67mm DOOR STILE - Silver

Extension rod and coupler for tall doors.

**Product Code:-**  
**RE-712** - 300mm EXTENSION  
**RE-714** - 600mm EXTENSION

Push bar, 1500mm, for wide doors, cut to suit.

**Product codes:-**  
**CB-748-AL** - 1219.2mm - CRASH BAR - Silver  
**CB-760-AL** - 1524mm - CRASH BAR - Silver  
Other finishes available to special order.

Dogging Pin  
**DP-713**

Locking handle  
**LH-725-AL** - 46mm DOOR STILE - Aluminium  
**LH-725-BK** - 46mm DOOR STILE - Black  
**LH-730-AL** - 49mm DOOR STILE - Aluminium  
**LH-740-AL** - 54mm DOOR STILE - Aluminium  
**LH-745-AL** - 67mm DOOR STILE - Aluminium

**GUARANTEE**

AXIM HANDLES ARE GUARANTEED FOR 12 MONTHS AGAINST DEFECT IN MATERIAL AND WORKMANSHIP. THIS GUARANTEE IS VOID IF THE PRODUCT HAS BEEN INCORRECTLY INSTALLED OR DAMAGED IN USE. CLAIMS FOR DAMAGE INCURRED OR WORK DONE THEREON WILL NOT BE ACCEPTED.  
AXIM RESERVE THE RIGHT TO UPDATE ITS PRODUCT SPECIFICATIONS WITHOUT PRIOR NOTICE.



**The Parkside Group Ltd**

The Willow Centre  
17 Willow Lane, Mitcham, Surrey, CR4 4NX  
Tel: 020-8685 9685 Fax: 020-8646 5096  
Email: axim@parksidegroup.co.uk  
Web Site: www.axim.co.uk

SCALE	NTS @A4
DATE	JULY 2017
For scaled technical or CAD drawings, please contact AXIM.	

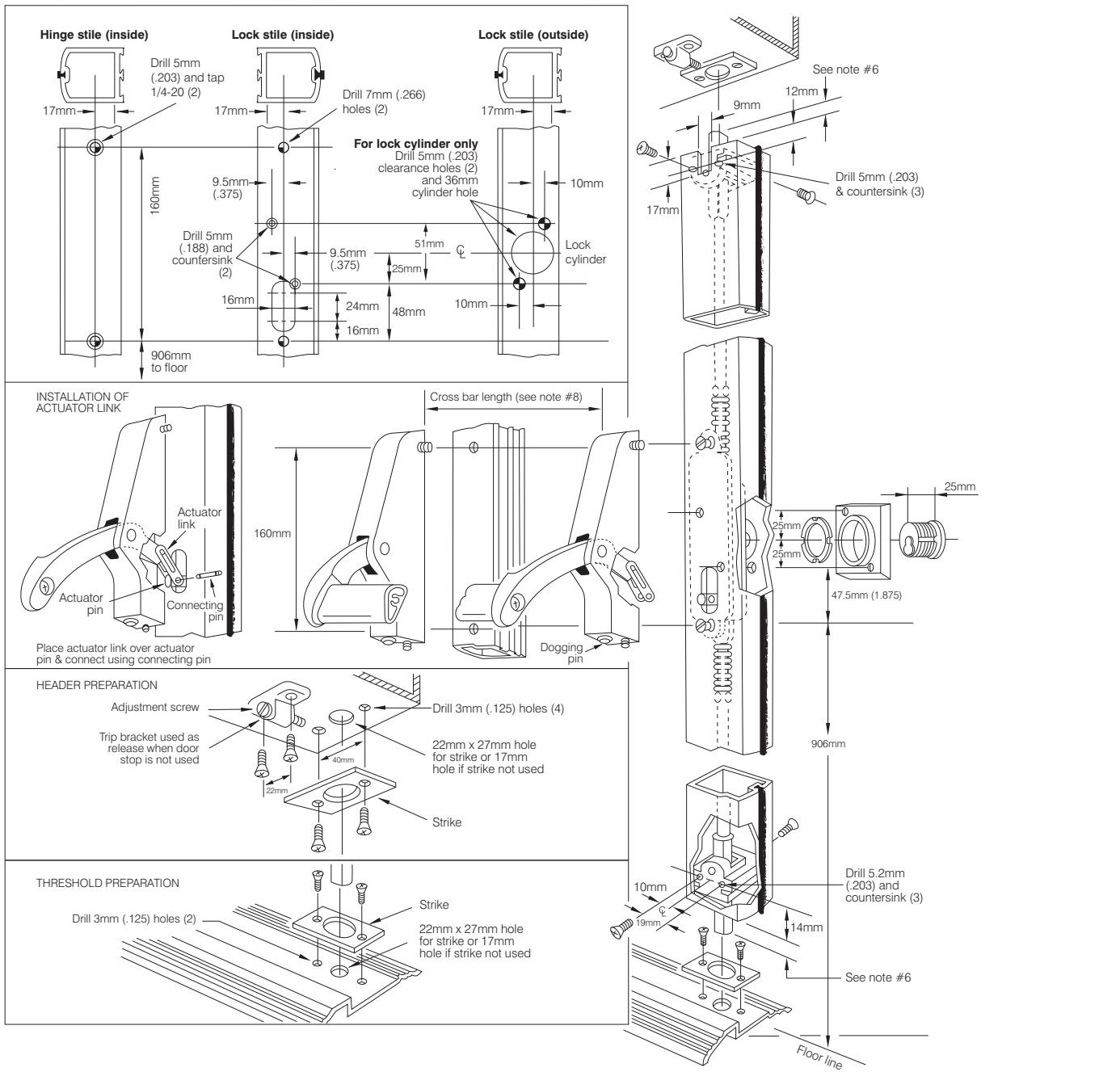

**MOUNTING INSTRUCTIONS**

- Determine hand of door and prepare inside of lock and hinge stiles as show.
- If Cylinder Key Lock is to be used, prepare inside and outside of lock stile as shown.
- Insert Rod and Case Assembly into lock stile and secure with (2) 1/4-20 Shoulder Studs.
- If Key Lock is used, insert Cylinder in Mounting Pad and secure with Locking Ring. Install using (2) #8-32x49mm Flat Head Machine Screws.
- Position Exit Pad over stile and attach Actuator Link to Actuator Pin using Connecting Pin provided. Place on stile over 1/4-20 Shoulder Studs and tighten 3 Socket Head Set Screws to secure in place.
- Adjust length of top and bottom Latch Bolts by turning in or out. When the Panic Arm is fully depressed, the Latch Bolts

should be slightly recessed from flush with the top and bottom of the door. NOTE: Flat notch side of Bolt **must** face the outside of the door. Install top and bottom Latch Bolt Guides using (6) #10x13mm Flat Head Self-threading Screws.

- Install (2) 1/4-20 Shoulder Studs on hinge stile. Place other Exit Pad over Studs and tighten 3 Socket Head Set Screws to secure in place.
- Measure distance from inside edge to inside edge of Exit pads for proper Cross Bar length. Cut Cross Bar. CAUTION: Cross Bar length must be within  $\pm 1$ mm for unit to function properly.
- Loosen 3 Set Screws on hinge stile Exit Pad and install Cross Bar using (2) 1/4-20x25mm Oval Head Self-threading Screws. Tighten 3 Set Screws to secure in place.
- Prepare header and threshold as shown. If Header and Threshold Strikes are required, install using (4) #8x25mm Flat Head All-purpose Screws.

**DOGGING EXIT DEVICE USING DOGGING PIN:**

Fully depress Cross Bar and hold, push up Dogging Pin with screwdriver and rotate 90° in either direction.

**TO RELEASE EXIT DEVICE:**

Hold Cross Bar down and rotate Dogging Pin with screwdriver in either direction until Dogging Pin releases.

**DOGGING EXIT DEVICE USING CYLINDER KEY:**

Fully depress Cross Bar and hold, turn Key clockwise approximately 60°, return Key to centre and remove.

**TO RELEASE EXIT DEVICE:**

Turn key counterclockwise 90°, return Key to centre and remove.



The Parkside Group Ltd

The Willow Centre  
17 Willow Lane, Mitcham, Surrey, CR4 4NX  
Tel: 020-8685 9685 Fax: 020-8646 5096  
Email: axim@parksidegroup.co.uk  
Web Site: www.axim.co.uk

SCALE	NTS @A4
DATE	MARCH 2014
For scaled technical or CAD drawings, please contact AXIM.	



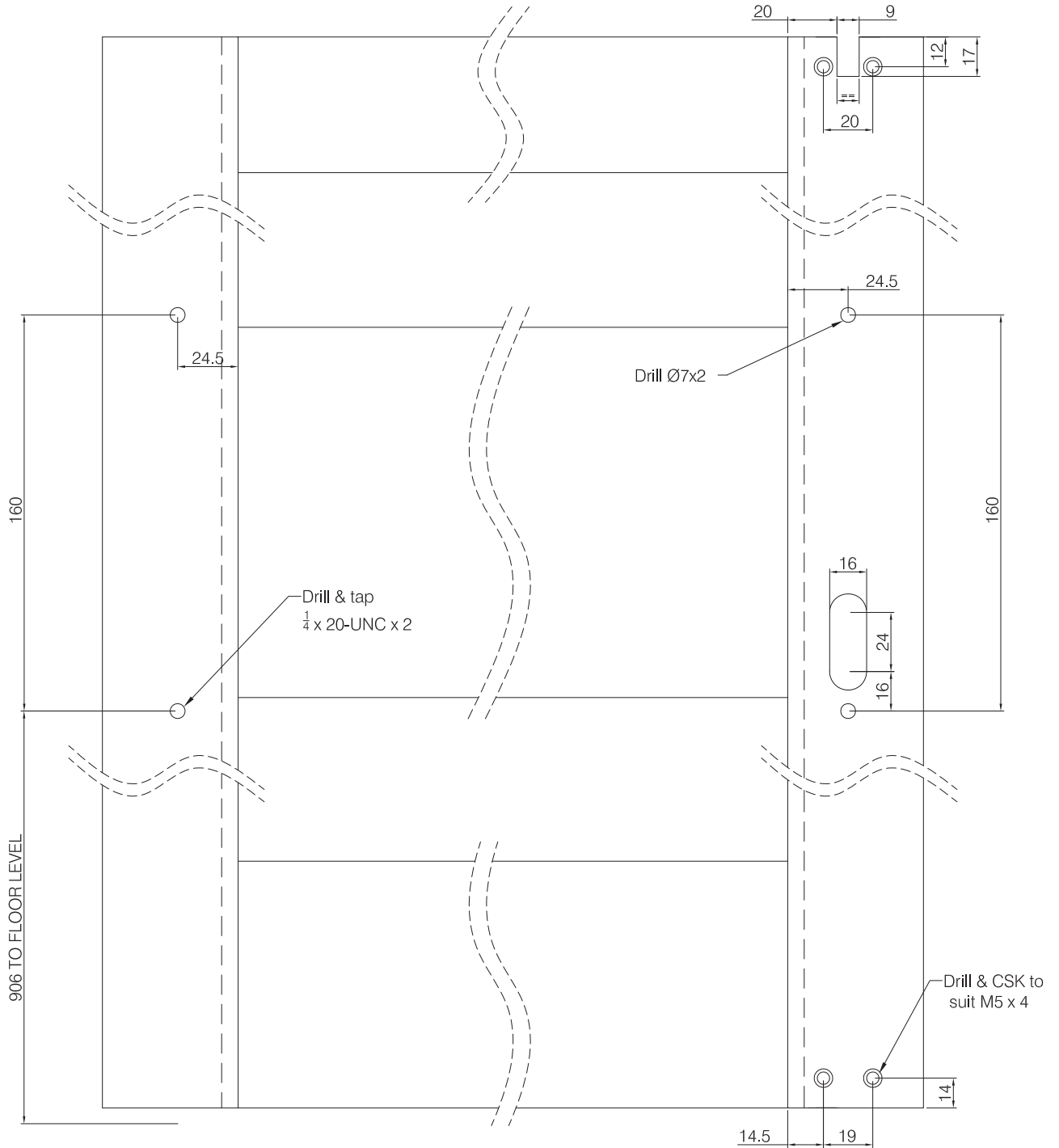
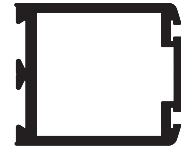
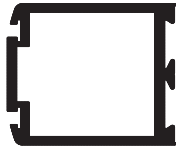

The Parkside Group Ltd

The Willow Centre  
17 Willow Lane, Mitcham, Surrey, CR4 4NX  
Tel: 020-8685 9685 Fax: 020-8646 5096  
Email: axim@parksidegroup.co.uk  
Web Site: www.axim.co.uk

SCALE	NTS @A4
DATE	JULY 2017

For scaled technical or CAD drawings,  
please contact AXIM.

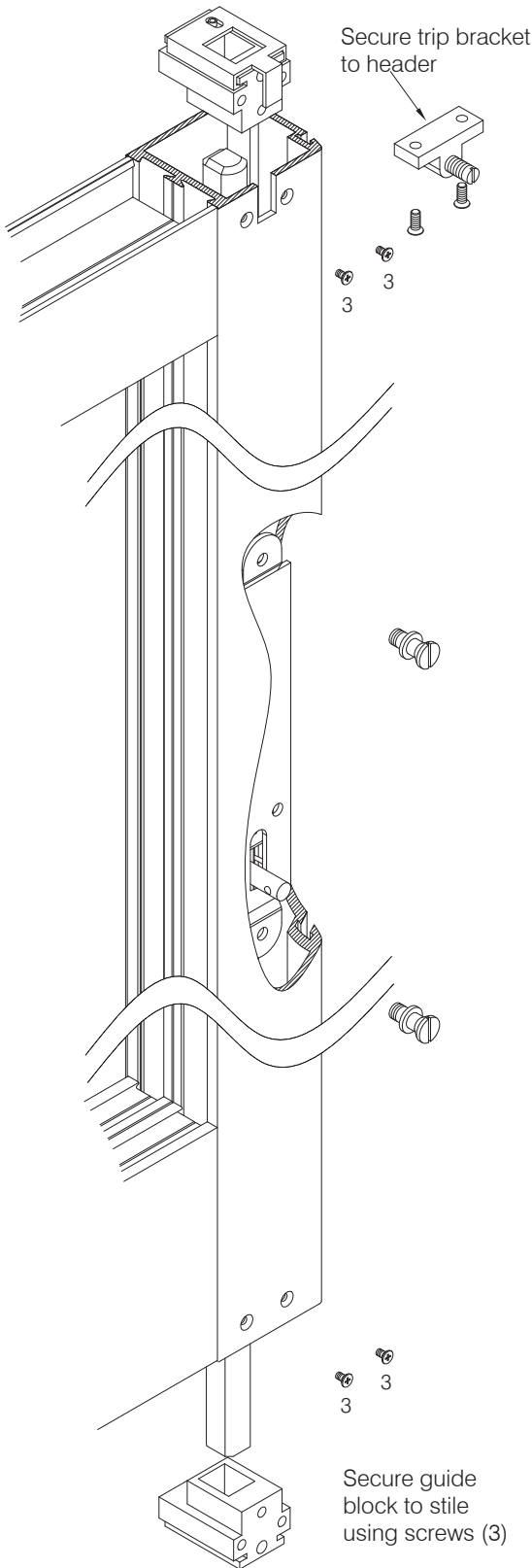

Secure fixing screws (1) thru stile into lock mechanism, and screws (2) into tapped holes in opposite stile.

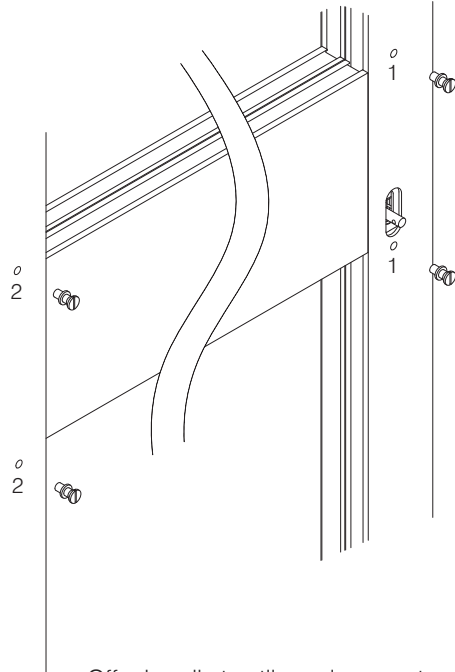

Offer handle to stile and connect actuator link to actuator pin using connecting pin (A) provided. Position handle onto fixing screws (B) and secure using grub screws (C).

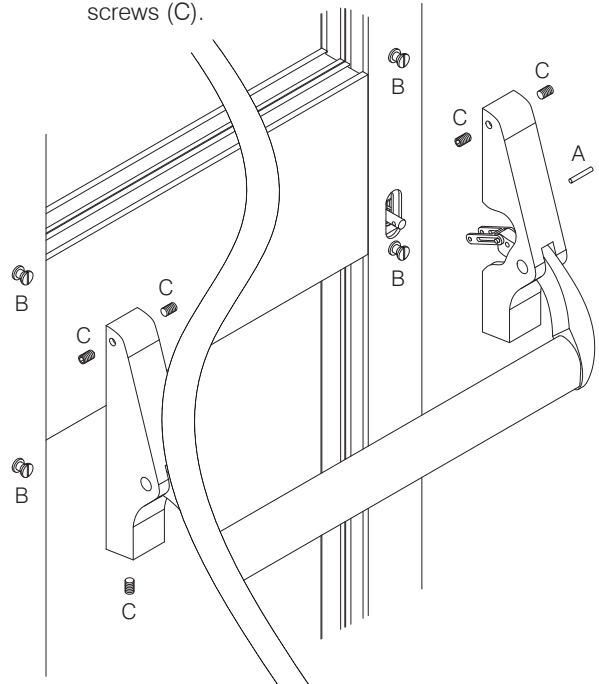

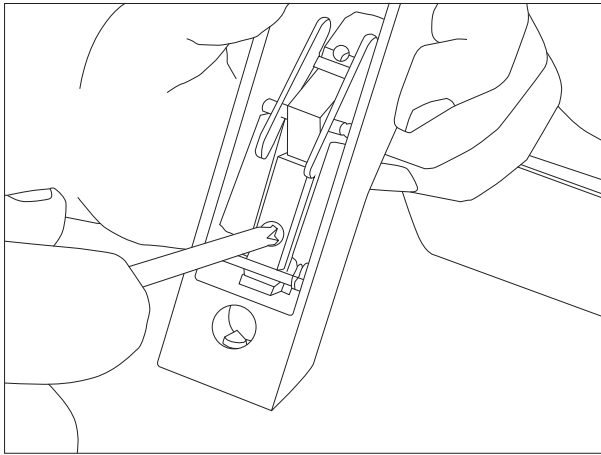

1) Remove securing screw in back of handle unit

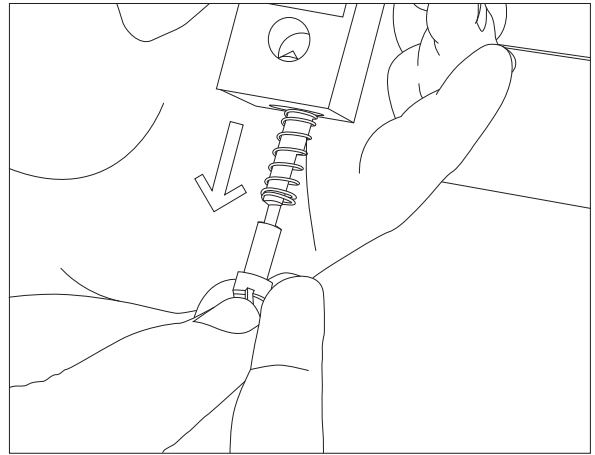

2) Once securing screw is removed existing pin should be ejected by internal spring

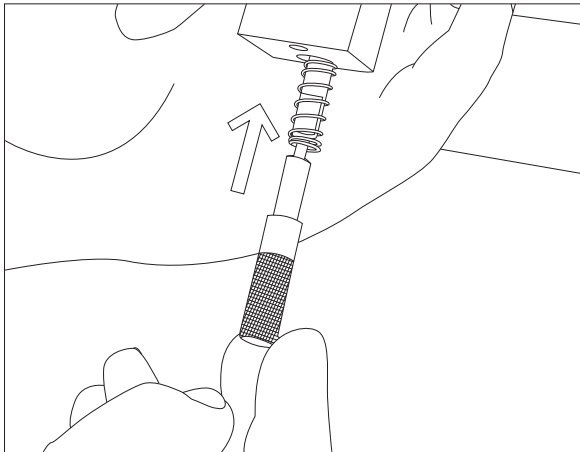

3) Replace existing pin with knurled pin (retaining original spring)

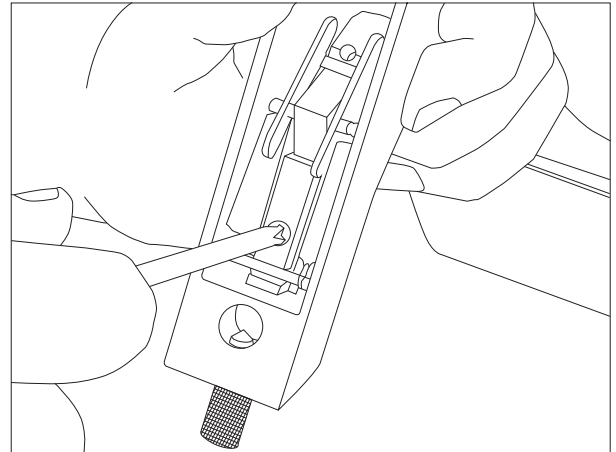

4) Replace securing screw holding knurled pin in far enough that notch on dogging pin can locate on securing screw

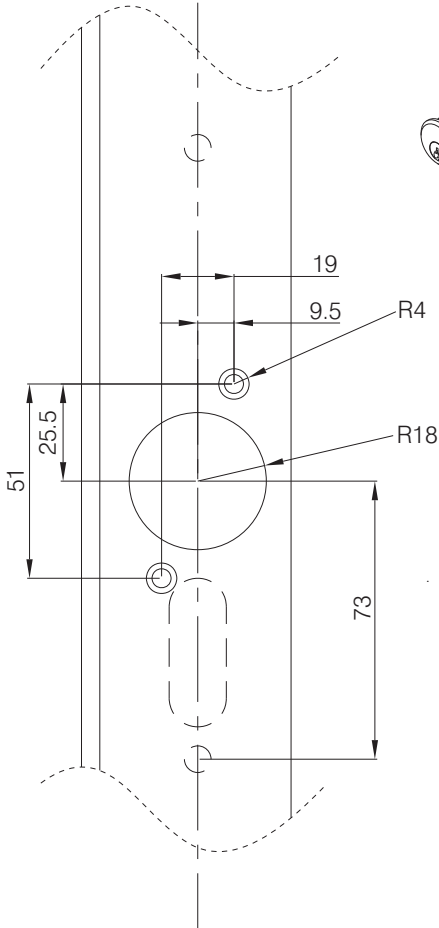
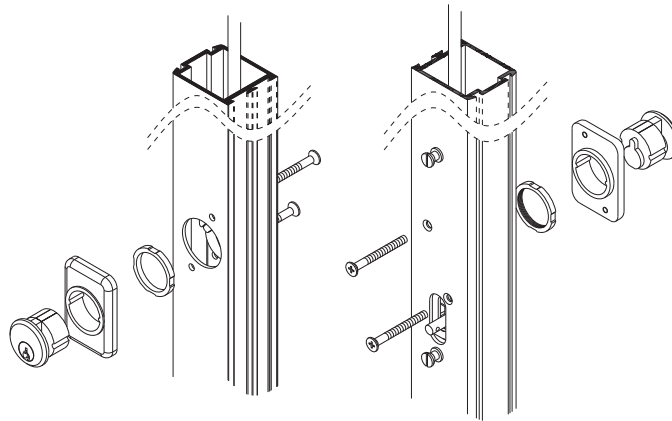
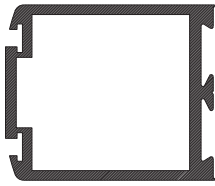

RC-785-AL Rim cylinder & mounting pad for use with 7085/7100 panic exit devices

Rim Cylinder table details		Mounting Pads	Screw Length
RC - 785			
A = 29.5	46mm Door Stile	MP786	S = 57 mm
B = 25.0			
C = 7.0			
D = 12.0			
E = 6.0			
RC - 787		MP790	S = 65 mm
A = 32.5	49mm Door Stile		
B = 28.6			
C = 5.0			
D = 13.0			
E = 10.0			
RC - 789		MP790	S = 65 mm
A = 37.5	54mm Door Stile		
B = 33.6			
C = 7.0			
D = 21.0			
E = 5.0			
RC - 791		MP792	S = 90 mm
A = 53.5	67mm Door Stile		
B = 49.0			
C = 5.0			
D = 14.0			
E = 27.0			



The Parkside Group Ltd

The Willow Centre  
17 Willow Lane, Mitcham, Surrey, CR4 4NX  
Tel: 020-8685 9685 Fax: 020-8646 5096  
Email: axim@parksidegroup.co.uk  
Web Site: www.axim.co.uk

SCALE	NTS @A4
DATE	JULY 2017

For scaled technical or CAD drawings, please contact AXIM.

**LH-725 Locking handle**

Key Controlled Outside trim for use with PR7085, PR7085P, and PR7100 concealed rod Panic Devices.

Uses Axim screw in Mortice cylinder with MS type CAM.

Not handed. (Field reversible).

All Axim Panic Exit Hardware is supplied with comprehensive instructions and full size templates for ease of installation.

Handle rotation 45° anti-clockwise from centre.

OR

Handle rotation 45° clockwise from centre.

See 4:08 for lock fitment.

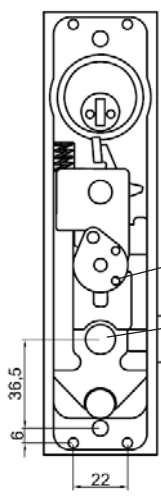
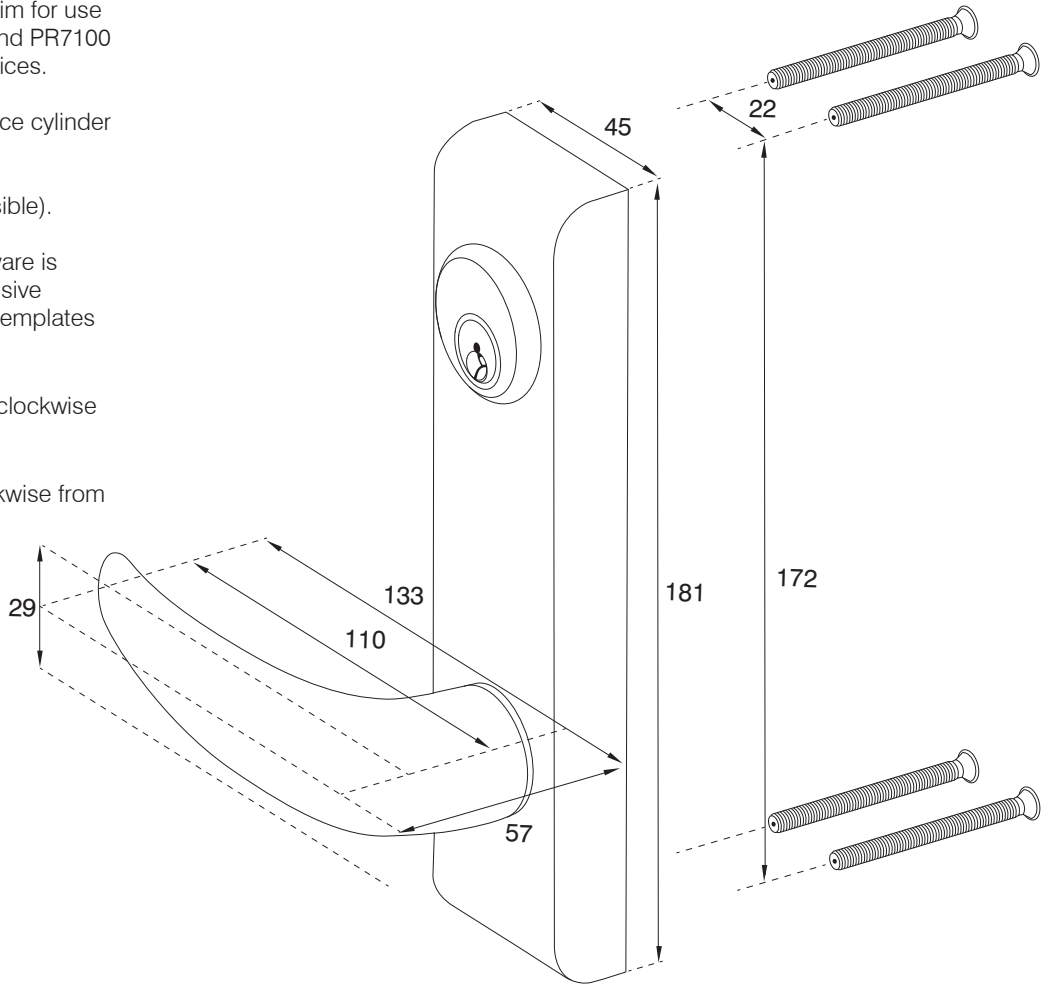

Ensure operating dowel is engaged in slot.

To change the hand of the trim, remove screw and reverse lever. Keep the black side of star washer facing upwards. Ensure screw is locked tight.

Ensure the cylinder and cam operate the lock arm prior to installation.

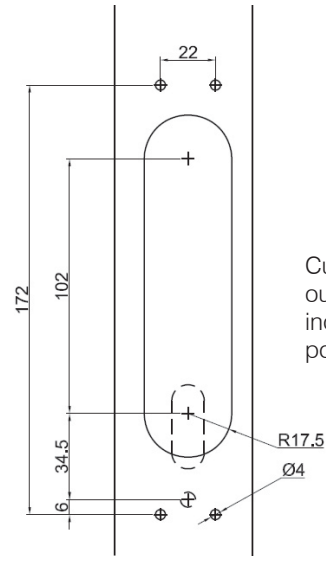

Cutting Prep to fit to outer face. Dashed lines indicate panic exit position (34.5 & 6).



**The Parkside Group Ltd**

The Willow Centre  
17 Willow Lane, Mitcham, Surrey, CR4 4NX  
Tel: 020-8685 9685 Fax: 020-8646 5096  
Email: axim@parksidegroup.co.uk  
Web Site: www.axim.co.uk

SCALE	NTS @A4
DATE	JULY 2017

For scaled technical or CAD drawings, please contact AXIM.

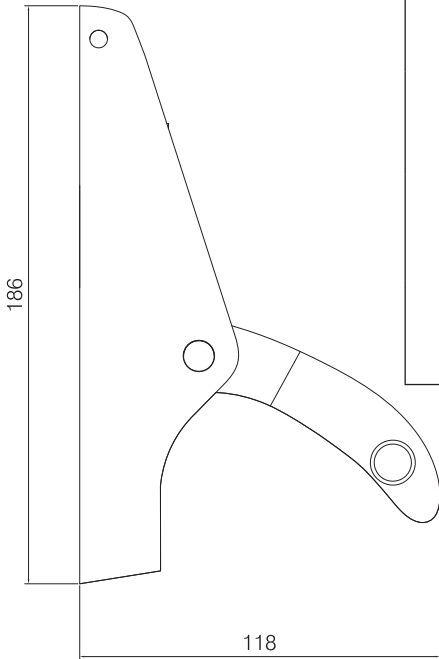

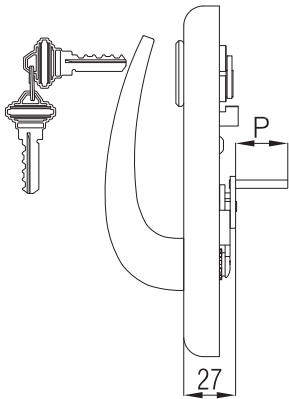
	Locking Handle	Pin Length	Door Stile
	LH-725	P = 6 mm	46mm
LH-730	P = 9 mm	49mm	
LH-740	P = 14 mm	54mm	
LH-745	P = 27 mm	67mm	

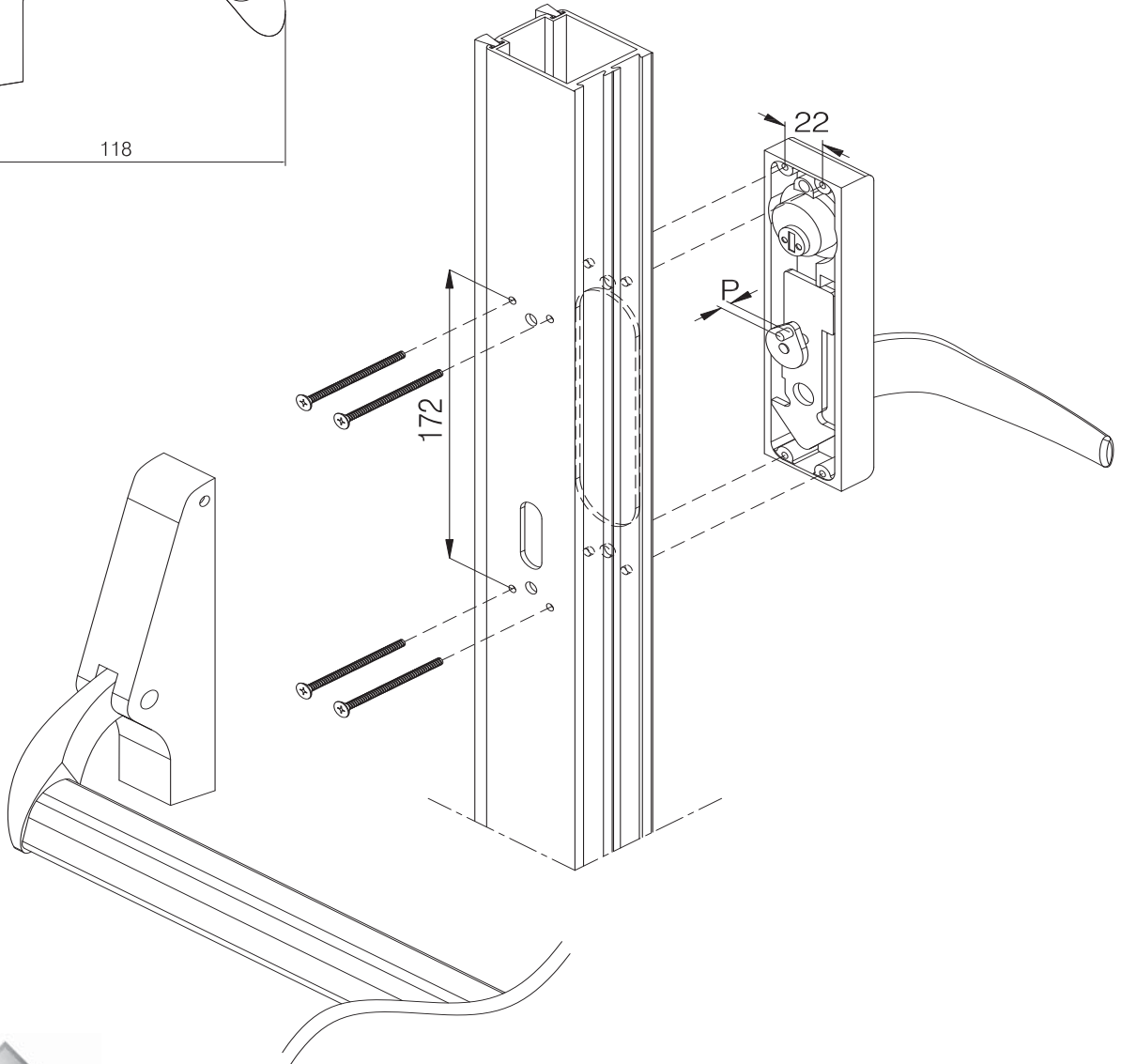

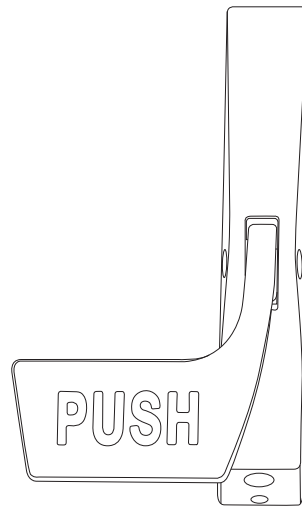

**CONCEALED ROD, PANIC EXIT DEVICE**

Heavy duty lever springs and internal mechanism for durable operation of lever and arm.

Plated steel and stainless steel components.

8.5mm diameter, steel locking rods with 16mm bolt throw.

Bolt length adjustable ensuring correct alignment.

Standard model suitable for all widths of doors and 2135mm high. 300mm and 600mm coupling rods are available for taller doors.

Available with standard mortice rim cylinder, handle and mounting pad allowing external access.

Permanent bolt retention for easy access can be achieved with cylinder key or dogging pin to the underside of the operating lever.

All Axim panic exit hardware is supplied with comprehensive instructions and full size templates for ease of installation.

**MATERIAL FINISH**

Lever Handles are satin chrome finish to complement most door colours and are clearly marked 'PUSH'.

**GUARANTEE**

AXIM HANDLES ARE GUARANTEED FOR 12 MONTHS AGAINST DEFECT IN MATERIAL AND WORKMANSHIP. THIS GUARANTEE IS VOID IF THE PRODUCT HAS BEEN INCORRECTLY INSTALLED OR DAMAGED IN USE. CLAIMS FOR DAMAGE INCURRED OR WORK DONE THEREON WILL NOT BE ACCEPTED. AXIM RESERVE THE RIGHT TO UPDATE ITS PRODUCT SPECIFICATIONS WITHOUT PRIOR NOTICE.

**SUGGESTED SPECIFICATION**

Concealed vertical rod panic exit devices with paddle handle fitted to inside face of door. Exit device to secure top and bottom of the door except during operation cycle or when rods are retracted with key or dogging pin.

Operating paddle handle and lever not to exceed 118mm x 186mm projection. All mounting screws to be concealed.

Handles and mechanisms will be fitted with heavy duty springs for durability. Ref; AXIM PR-7085P (hand as specified)

**ACCESSORIES**

Extension rod with coupling for doors over 2135mm high (plated steel)

**Ref: RE-712** - 300mm Extension Rod

**RE-714** - 600mm Extension Rod

Rim cylinder for access from outside

**RC-795-AL** - 46mm TO 54mm DOOR STILE - Silver

**RC-795-AL-S** - 46mm TO 54mm DOOR STILE - Silver

**RC-785-DU** - 46mm DOOR STILE - Bronze

**RC-785-BK** - 46mm DOOR STILE - Black

**RC-787-AL** - 46mm DOOR STILE - Silver

**RC-789-AL** - 54mm DOOR STILE - Silver

**RC-791-AL** - 67mm DOOR STILE - Silver

Cylinder mounting pad for above including fixings

**MP-786-AL** - 46mm DOOR STILE - Silver

**MP-786-DU** - 46mm DOOR STILE - Bronze

**MP-786-BK** - 46mm DOOR STILE - Black

Paddle handle housing unit

**PH-785-AL-LH** - LEFT HAND - Silver

**PH-785-AL-RH** - RIGHT HAND - Silver

Dogging pin

**DP-713**

Locking handles

**LH-725-AL** - 46mm - Silver

**LH-725-BK** - 46mm - Black

**LH-730-AL** - 49mm - Silver

**LH-740-AL** - 54mm - Silver

**LH-745-AL** - 67mm - Silver

**HAND OF DOOR**

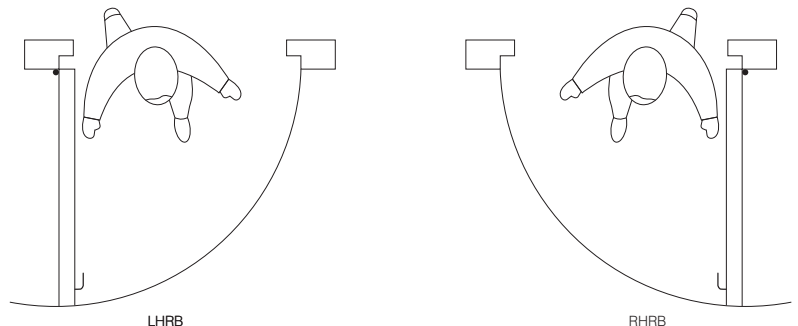

**The Parkside Group Ltd**

The Willow Centre  
17 Willow Lane, Mitcham, Surrey, CR4 4NX  
Tel: 020-8685 9685 Fax: 020-8646 5096  
Email: axim@parksidegroup.co.uk  
Web Site: www.axim.co.uk

SCALE	NTS @A4
DATE	DECEMBER 2017

For scaled technical or CAD drawings, please contact AXIM.

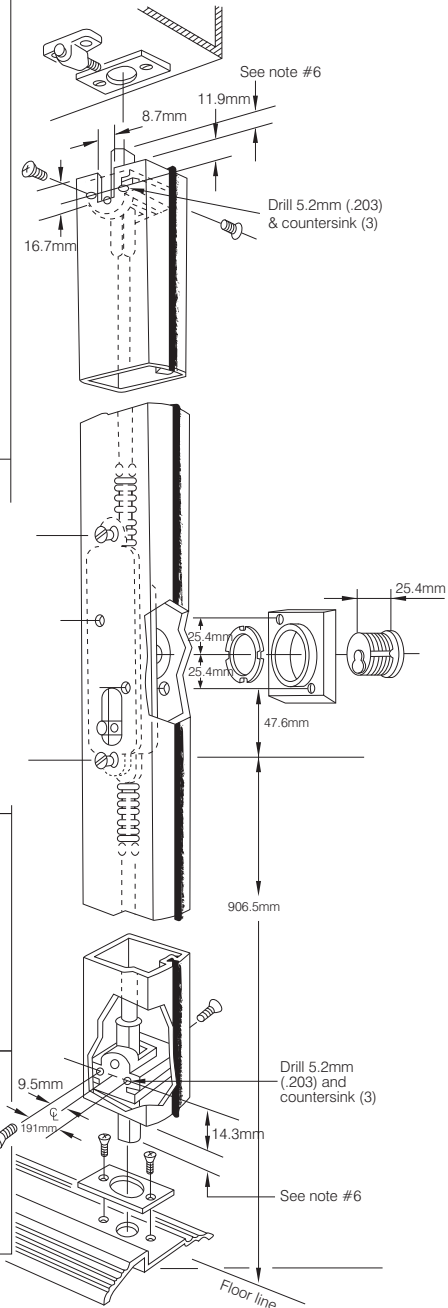
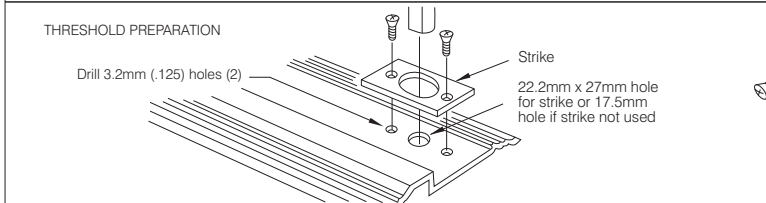
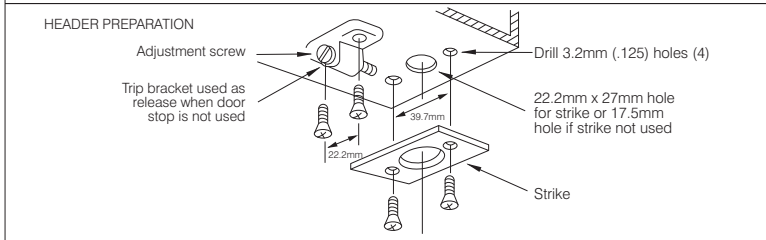
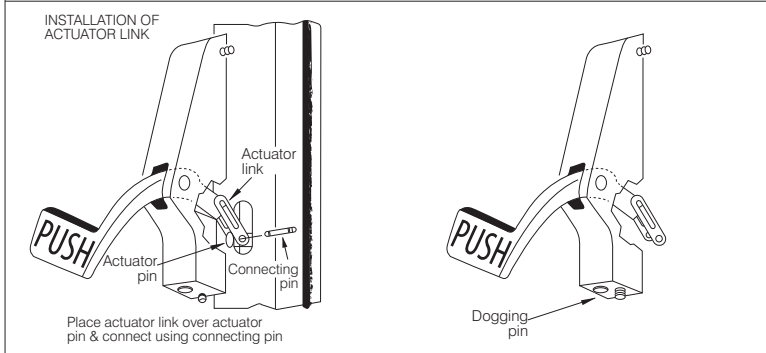
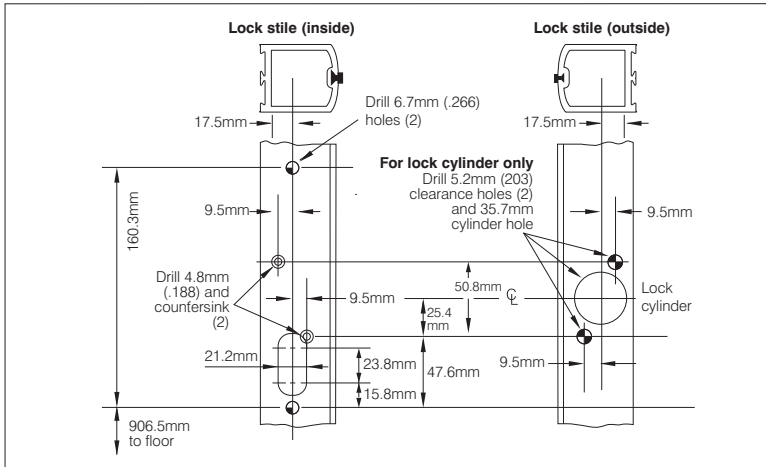

**MOUNTING INSTRUCTIONS**

- Determine hand of door and prepare inside of lock and hinge stiles as show.
- If Cylinder Key Lock is to be used, prepare inside and outside of lock stile as shown.
- Insert Rod and Case Assembly into lock stile and secure with (2) 1/4-20 Shoulder Studs.
- If Key Lock is used, insert Cylinder in Mounting Pad and secure with Locking Ring. Install using (2) #8-32x1-23.8mm Flat Head Machine Screws.
- Position Exit Pad over stile and attach Actuator Link to Actuator Pin using Connecting Pin provided. Place on stile over 1/4-20 Shoulder Studs and tighten 3 Socket Head Set Screws to secure in place.

- Adjust length of top and bottom Latch Bolts by turning in or out. When the Panic Arm is fully depressed, the Latch Bolts should be slightly recessed from flush with the top and bottom of the door. NOTE: Flat notch side of Bolt **must** face the outside of the door. Install top and bottom Latch Bolt Guides using (6) #10x12.7mm Flat Head Self-threading Screws.
- Install (2) 1/4-20 Shoulder Studs on hinge stile. Place other Exit Pad over Studs and tighten 3 Socket Head Set Screws to secure in place.
- Prepare header and threshold as shown. If Header and Threshold Strikes are required, install using (4) #8x9.5mm Flat Head Self-threading Screws or (4) #8x25.4mm Flat Head All-purpose screws.

**DOGGING EXIT DEVICE USING DOGGING PIN:**  
Fully depress push paddle and hold, push up Dogging Pin with screwdriver and rotate 90° in either direction.

**TO RELEASE EXIT DEVICE:**  
Hold push paddle down and rotate Dogging Pin with screwdriver in either direction until Dogging Pin releases.

**DOGGING EXIT DEVICE USING CYLINDER KEY:**  
Fully depress push paddle and hold, turn Key clockwise approximately 60°, return Key to centre and remove.

**TO RELEASE EXIT DEVICE:**  
Turn key counterclockwise 90°, return Key to centre and remove.



The Parkside Group Ltd

The Willow Centre  
17 Willow Lane, Mitcham, Surrey, CR4 4NX  
Tel: 020-8685 9685 Fax: 020-8646 5096  
Email: axim@parksidegroup.co.uk  
Web Site: www.axim.co.uk

SCALE	NTS @A4
DATE	MARCH 2014
For scaled technical or CAD drawings, please contact AXIM.	



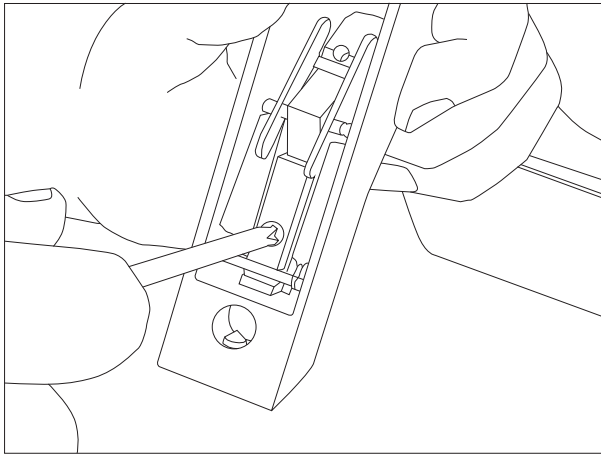

1) Remove securing screw in back of handle unit

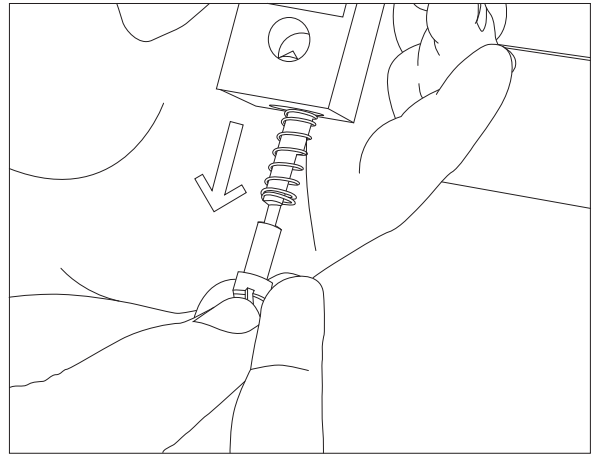

2) Once securing screw is removed existing pin should be ejected by internal spring

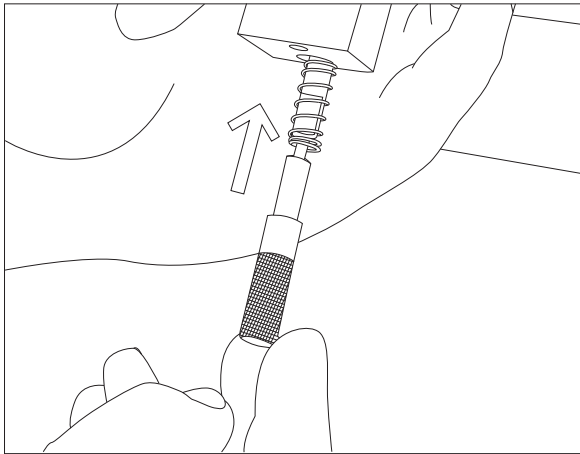

3) Replace existing pin with knurled pin (retaining original spring)

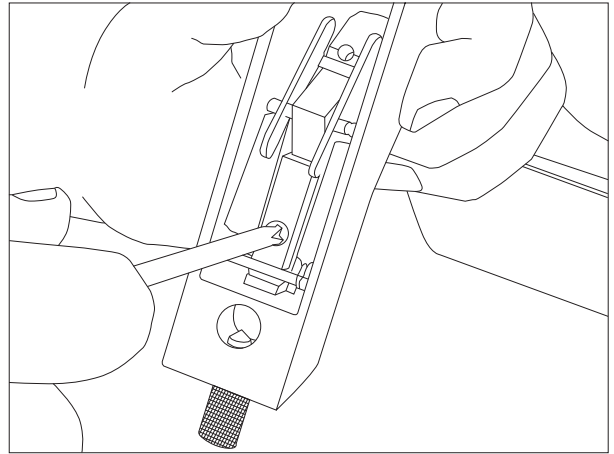

4) Replace securing screw holding knurled pin in far enough that notch on dogging pin can locate on securing screw

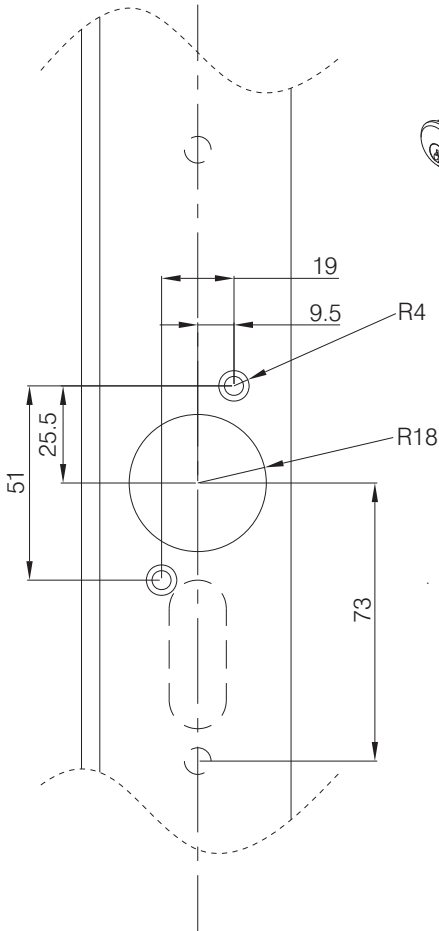
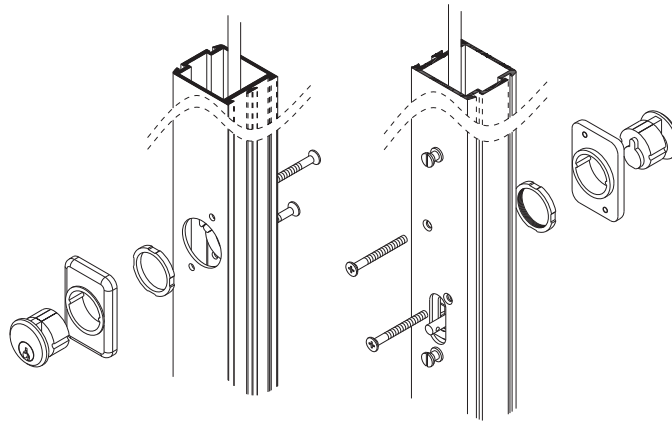
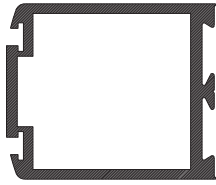

RC-785-AL Rim cylinder & mounting pad for use with 7085/7100 panic exit devices

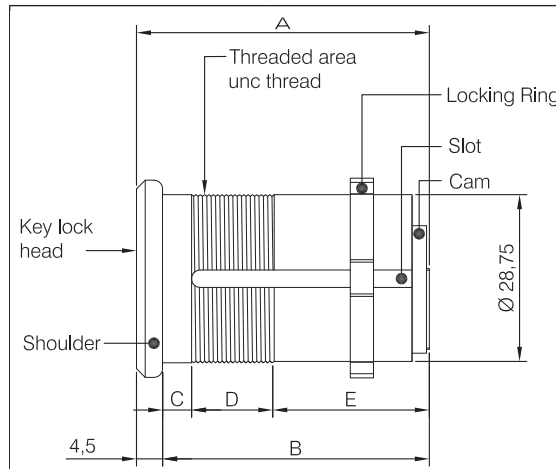
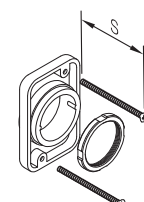
			
Rim Cylinder table details		Mounting Pads	Screw Length
RC - 785			
A = 29.5	46mm Door Stile	MP786	S = 57 mm
B = 25.0			
C = 7.0			
D = 12.0			
E = 6.0			
RC - 787		MP790	S = 65 mm
A = 32.5	49mm Door Stile		
B = 28.6			
C = 5.0			
D = 13.0			
E = 10.0			
RC - 789		MP790	S = 65 mm
A = 37.5	54mm Door Stile		
B = 33.6			
C = 7.0			
D = 21.0			
E = 5.0			
RC - 791		MP792	S = 90 mm
A = 53.5	67mm Door Stile		
B = 49.0			
C = 5.0			
D = 14.0			
E = 27.0			



The Parkside Group Ltd

The Willow Centre  
17 Willow Lane, Mitcham, Surrey, CR4 4NX  
Tel: 020-8685 9685 Fax: 020-8646 5096  
Email: axim@parksidegroup.co.uk  
Web Site: www.axim.co.uk

SCALE	NTS @A4
DATE	JULY 2017

For scaled technical or CAD drawings, please contact AXIM.

**LH-725 Locking handle**

Key Controlled Outside trim for use with PR7085, PR7085P, and PR7100 concealed rod Panic Devices.

Uses Axim screw in Mortice cylinder with MS type CAM.

Not handed. (Field reversible).

All Axim Panic Exit Hardware is supplied with comprehensive instructions and full size templates for ease of installation.

Handle rotation 45° anti-clockwise from centre.

OR

Handle rotation 45° clockwise from centre.

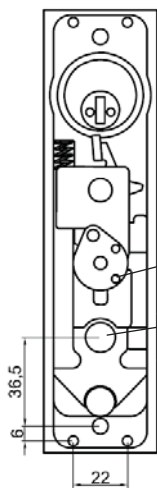
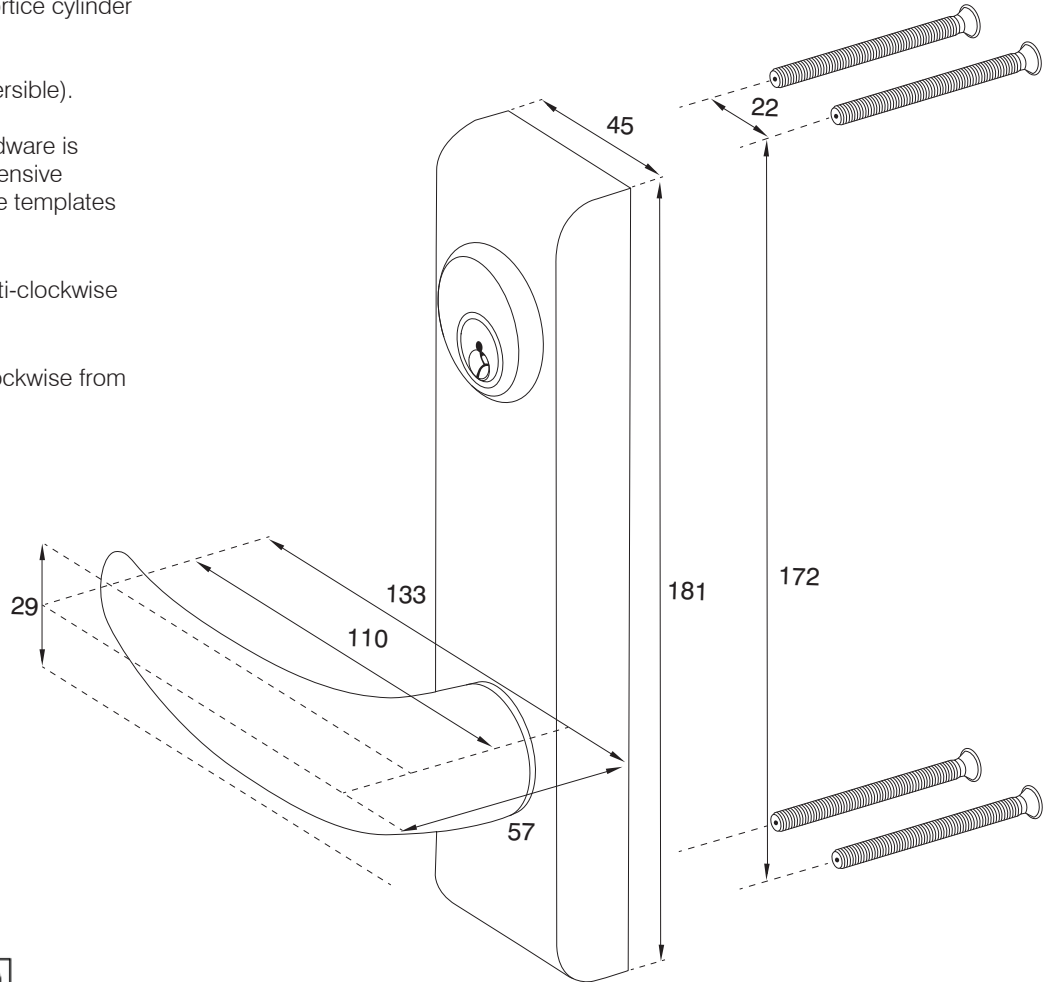

Ensure operating dowel is engaged in slot.

To change the hand of the trim, remove screw and reverse lever. Keep the black side of star washer facing upwards. Ensure screw is locked tight.

Ensure the cylinder and cam operate the lock arm prior to installation.

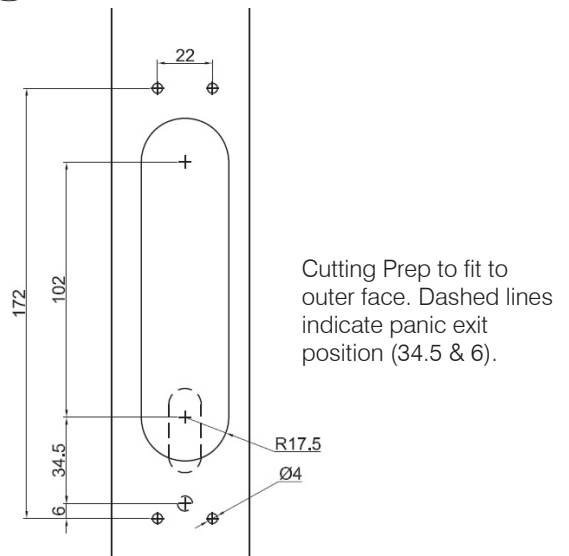

**The Parkside Group Ltd**

The Willow Centre  
17 Willow Lane, Mitcham, Surrey, CR4 4NX  
Tel: 020-8685 9685 Fax: 020-8646 5096  
Email: axim@parksidegroup.co.uk  
Web Site: www.axim.co.uk

SCALE	NTS @A4
DATE	JULY 2017
For scaled technical or CAD drawings, please contact AXIM.	

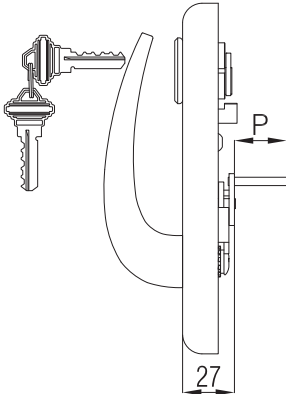

Locking Handle	Pin Length	Door Stile
LH-725	P = 6 mm	46mm
LH-730	P = 9 mm	49mm
LH-740	P = 14 mm	54mm
LH-745	P = 27 mm	67mm

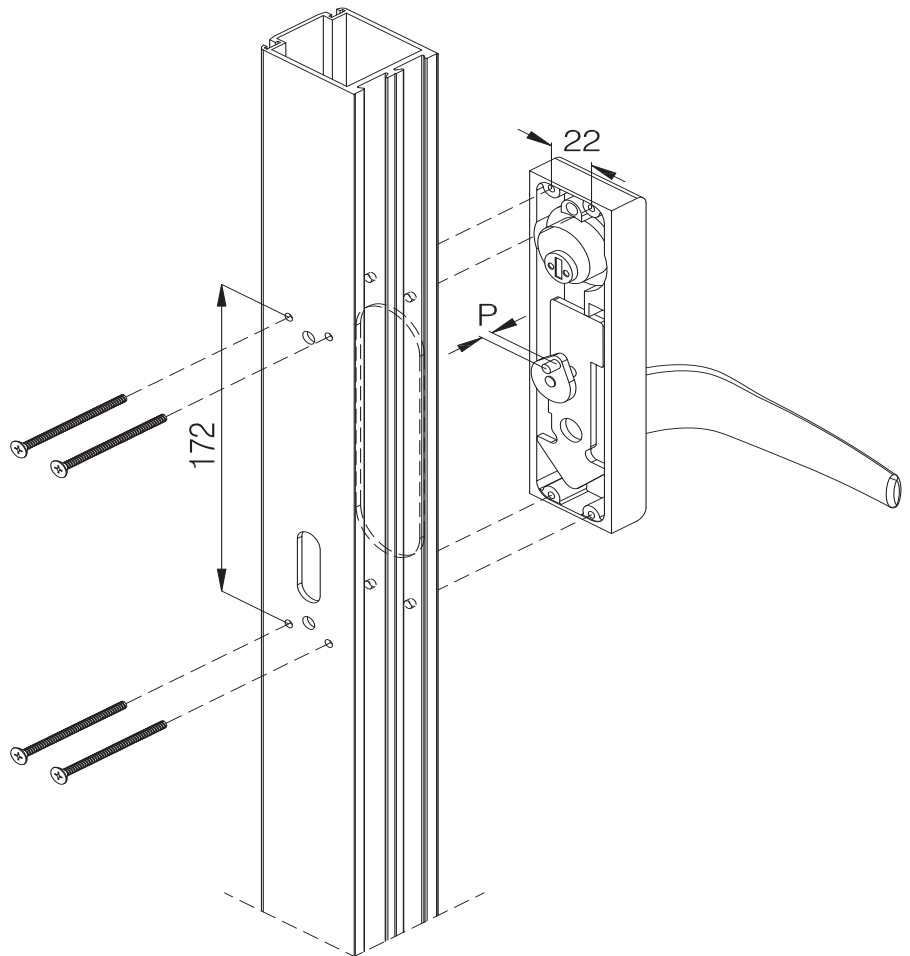
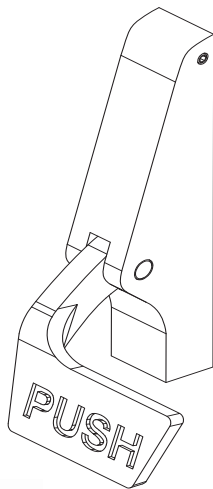
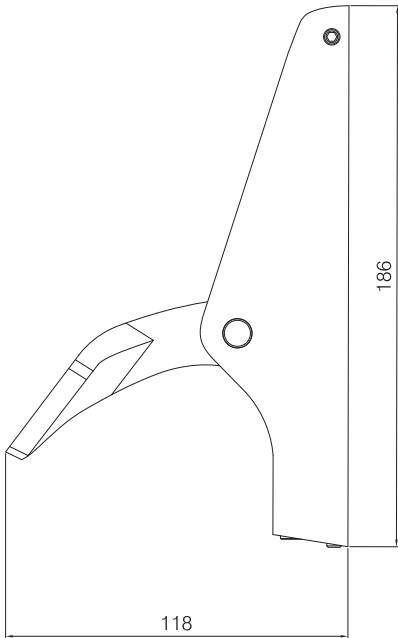

**The Parkside Group Ltd**

The Willow Centre  
17 Willow Lane, Mitcham, Surrey, CR4 4NX  
Tel: 020-8685 9685 Fax: 020-8646 5096  
Email: axim@parksidegroup.co.uk  
Web Site: www.axim.co.uk

SCALE NTS @A4

DATE JULY 2017

For scaled technical or CAD drawings,  
please contact AXIM.

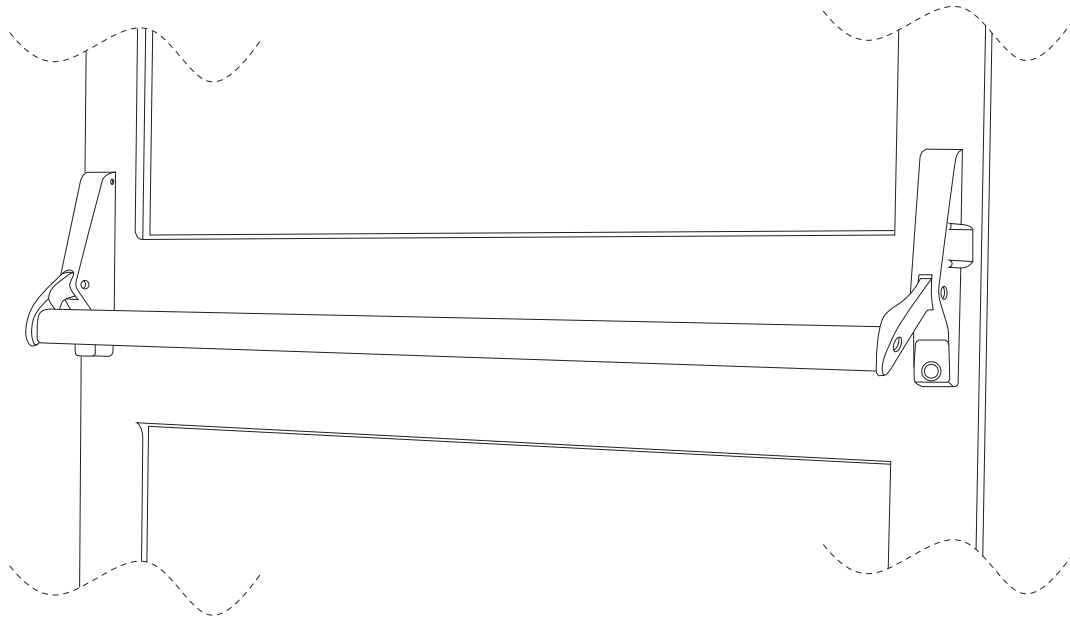

**HAND OF DOOR**

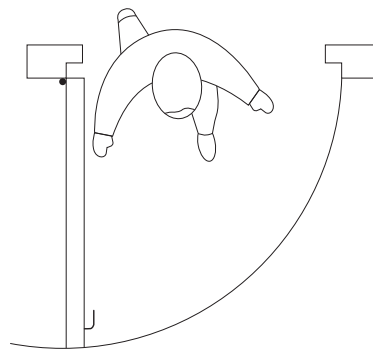

LHRB

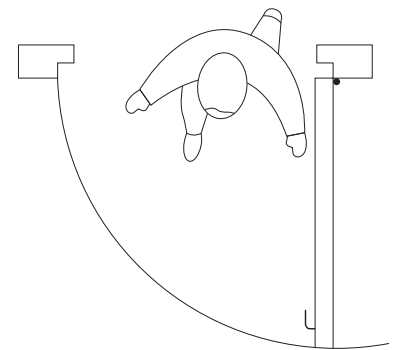

RHRB

**RIM MOUNTED, PANIC EXIT DEVICE**

Matching active and in-active housings to present a balanced appearance. Housings assembled to be right or left handed. Please check handing and specify when ordering.  
Heavy duty lever springs for durable operation of lever arms.  
Hardened latch bolt for added security.  
Narrow width, surface mounted strike supplied, adjustable after installation.  
Standard model suitable for doors of up to 1155mm wide.  
1500mm long crossbars available for extra wide doors. Cross bars can be cut to suit exact requirement.  
Available with standard rim cylinder that can be fitted directly to the door allowing operation from the outside.  
Permanent latch retention by either cylinder key from outside or concealed pins under levers.  
Anodised crossbars in:-  
Silver Satin, Dark Bronze & Black.  
Housings and lever arms stoved, abrasive resistant finish to match anodised finishes.  
Easy to follow instructions and full size templates supplied with every unit.

**ACCESSORIES**

Rim cylinder for access from outside. (2 keys.)  
**RC-795-AL** - 46mm to 54mm DOOR STILE - Silver  
**RC-795-DU** - 46mm to 54mm DOOR STILE - Bronze  
**RC-795-BK** - 46mm to 54mm DOOR STILE - Black  
**RC-795-AL-S** - 46mm to 54mm DOOR STILE - Silver  
**RC-797-AL** - 46mm to 67mm DOOR STILE - Silver  
**RC-797-AL-S** - 46mm to 67mm DOOR STILE - Silver

Push bar, 1500mm. For wide doors cut to suit.  
**CB-742-AL** - 1066.8mm - CRASH BAR - Silver  
**CB-748-AL** - 1219.2mm - CRASH BAR - Silver  
**CB-760-AL** - 1524mm - CRASH BAR - Silver  
Other finishes available to special order.

**Paddle handle**

**PR-7095-AL-L** - Left hand - Silver  
**PR-7095-AL-R** - Right hand - Silver  
**PR-7095-P-AL-LH** - Left hand - Silver  
**PR-7095-P-AL-RH** - Right hand - Silver  
Other finishes available to special order.

**GUARANTEE**

AXIM HANDLES ARE GUARANTEED FOR 12 MONTHS AGAINST DEFECT IN MATERIAL AND WORKMANSHIP. THIS GUARANTEE IS VOID IF THE PRODUCT HAS BEEN INCORRECTLY INSTALLED OR DAMAGED IN USE. CLAIMS FOR DAMAGE INCURRED OR WORK DONE THEREON WILL NOT BE ACCEPTED.  
AXIM RESERVE THE RIGHT TO UPDATE ITS PRODUCT SPECIFICATIONS WITHOUT PRIOR NOTICE.



**The Parkside Group Ltd**

The Willow Centre  
17 Willow Lane, Mitcham, Surrey, CR4 4NX  
Tel: 020-8685 9685 Fax: 020-8646 5096  
Email: axim@parksidegroup.co.uk  
Web Site: www.axim.co.uk

SCALE	NTS @A4
DATE	JULY 2017
For scaled technical or CAD drawings, please contact AXIM.	

L.H.R.B. Door shown

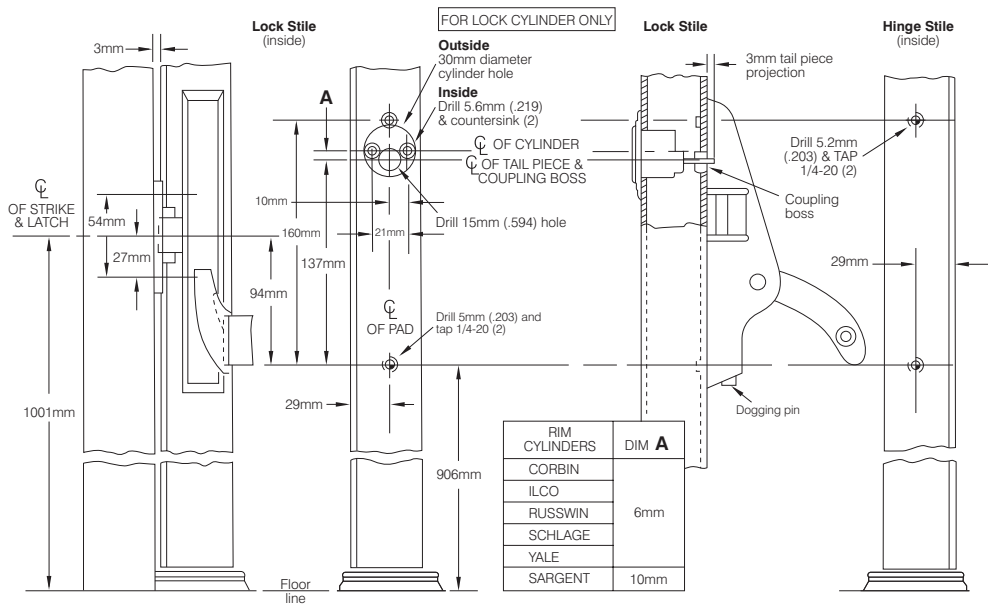
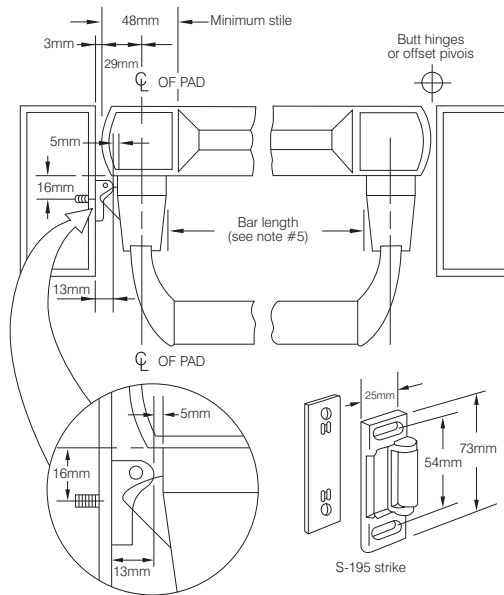

**Preparation**

- Determine hand of door and prepare inside of lock and hinge stiles as shown.
- If cylinder Key Lock is to be used, prepare inside and outside of lock stile as shown.
  - A Cut Spindle of Rim Cylinder to project thru the door 3mm. Install Rim Cylinder and secure with (2) 12-24x29mm Machine Screws. NOTE: Screw heads must be flush.
  - B Determine Function of Key Cylinder:
    - (1) STANDARD: Key removable in either locked or unlocked position. With Latch fully released, rotate Coupling Boss so index mark is up.
    - (2) NIGHT LATCH: Key removable in locked position only. With latch fully released, rotate Coupling Boss 90° towards hinge side.

- Install (2) 1/4-20 Shoulder Studs on lock stile and position Exit Latch Pad over Studs and insert Cylinder Spindle into Coupling Boss. Place Pad over Studs and tighten 3 Socket Head Set Screws to secure in place.
- Install (2) 1/4-20 Shoulder Studs on hinge stile and place other Exit Pad over Studs and tighten 3 Socket Head Set Screws to secure in place.
- Measure distance from inside edge to inside edge of Exit Pads for proper Cross Bar length. Cut Cross Bar. CAUTION: Cross Bar length must be within ± 1mm for unit to function properly.
- Loosen 3 Set Screws on hinge stile Exit Pad and install Cross Bar using (2) 1/4-20 x25mm Oval Head Self-threading Screws. Tighten 3 Set Screws to secure in place.
- Prepare lock jamb for Strike as shown and install using (2) #10 x 13mm Flat Head Self-threading Screws or #10 x 32mm All-purpose Screws.

**DOGGING EXIT DEVICE USING DOGGING PIN:**  
Fully depress Cross Bar and hold, push up Dogging Pin with screwdriver and rotate 90° in either direction.

**TO RELEASE EXIT DEVICE:**  
Hold Cross Bar down and rotate Dogging Pin with screwdriver in either direction until Dogging Pin releases.

**DOGGING EXIT DEVICE USING CYLINDER KEY:**  
Turn Key toward hinge side approximately 360°.

**TO RELEASE EXIT DEVICE:**  
Turn Key toward latch side approximately 360°.



The Parkside Group Ltd

The Willow Centre  
17 Willow Lane, Mitcham, Surrey, CR4 4NX  
Tel: 020-8685 9685 Fax: 020-8646 5096  
Email: axim@parksidegroup.co.uk  
Web Site: www.axim.co.uk

SCALE	NTS @A4
DATE	MARCH 2014
For scaled technical or CAD drawings, please contact AXIM.	

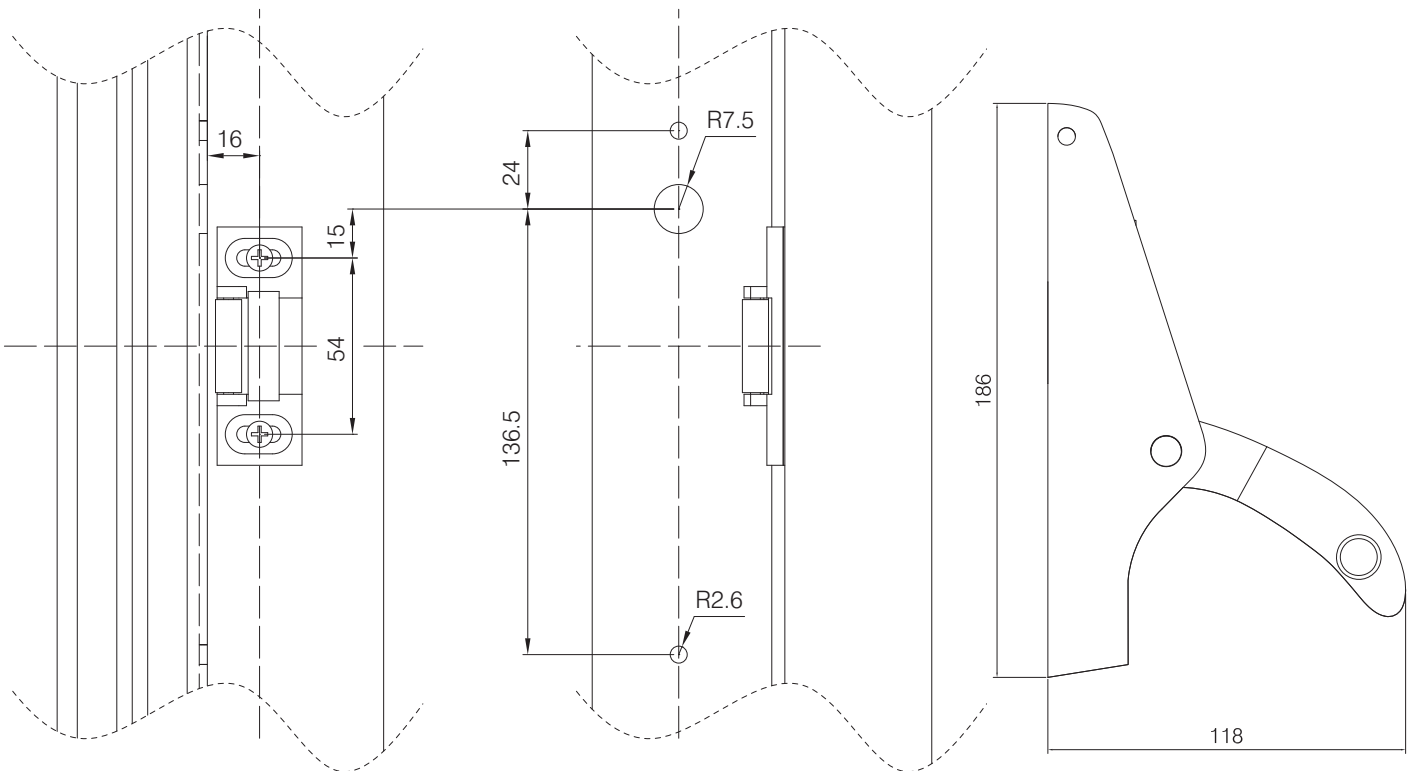
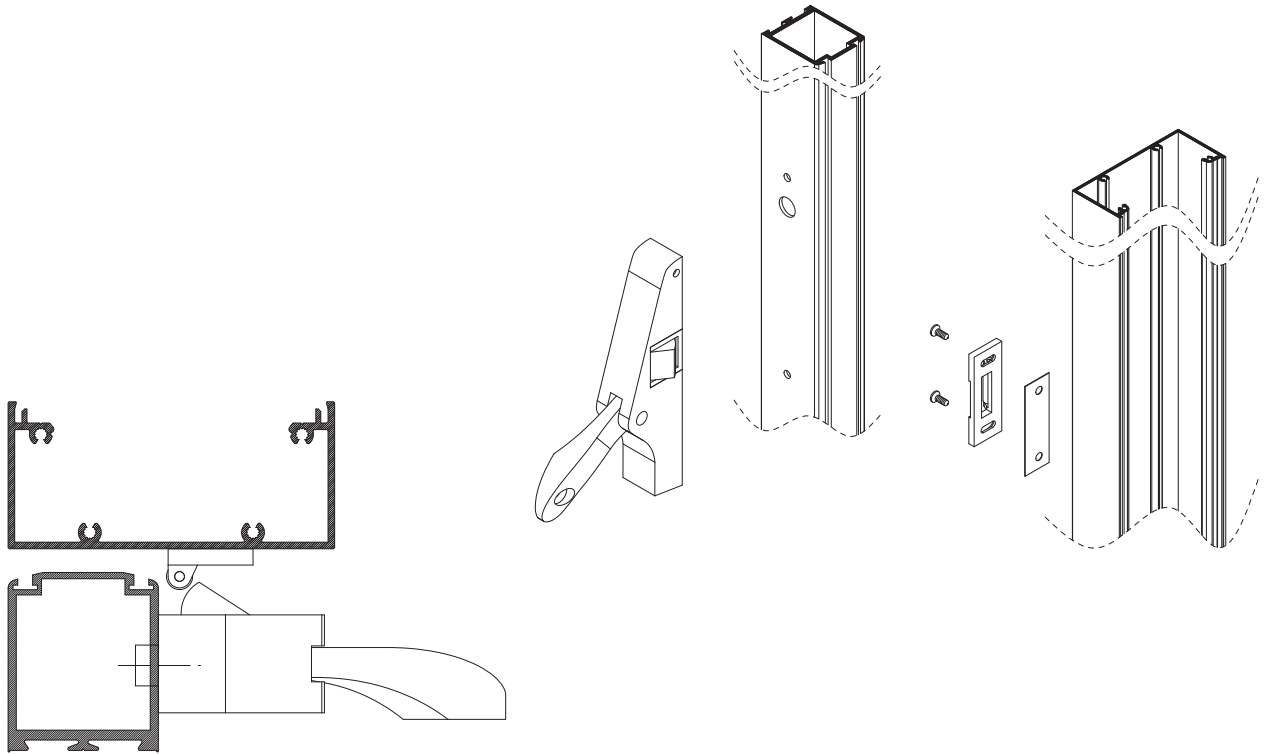

**The Parkside Group Ltd**

The Willow Centre  
17 Willow Lane, Mitcham, Surrey, CR4 4NX  
Tel: 020-8685 9685 Fax: 020-8646 5096  
Email: axim@parksidegroup.co.uk  
Web Site: www.axim.co.uk

SCALE	NTS @A4
DATE	JULY 2017

For scaled technical or CAD drawings,  
please contact AXIM.

RC-795-AL Rim cylinder & mounting pad for use with 7095 panic exit devices

RC 795 AL Rim cylinder for use with 7095 panic exit device

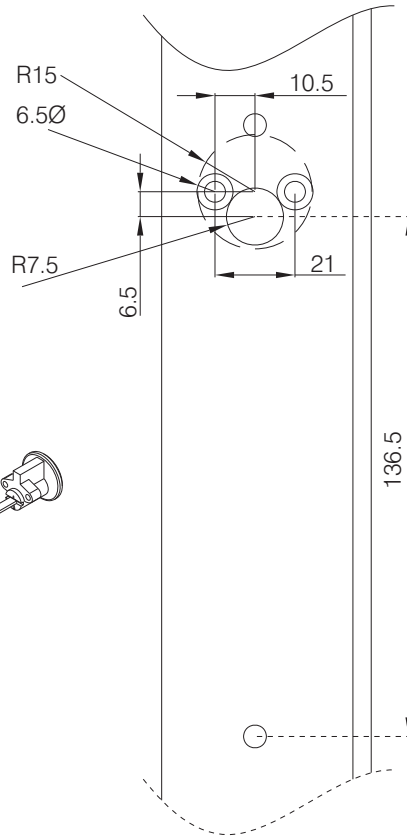
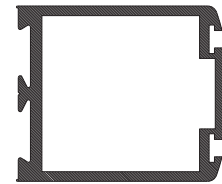
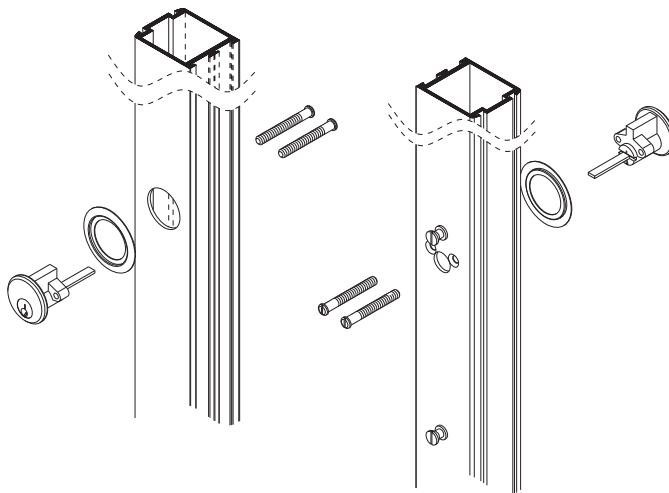

The Parkside Group Ltd

The Willow Centre  
17 Willow Lane, Mitcham, Surrey, CR4 4NX  
Tel: 020-8685 9685 Fax: 020-8646 5096  
Email: axim@parksidegroup.co.uk  
Web Site: www.axim.co.uk

SCALE	NTS @A4
DATE	JULY 2017

For scaled technical or CAD drawings, please contact AXIM.



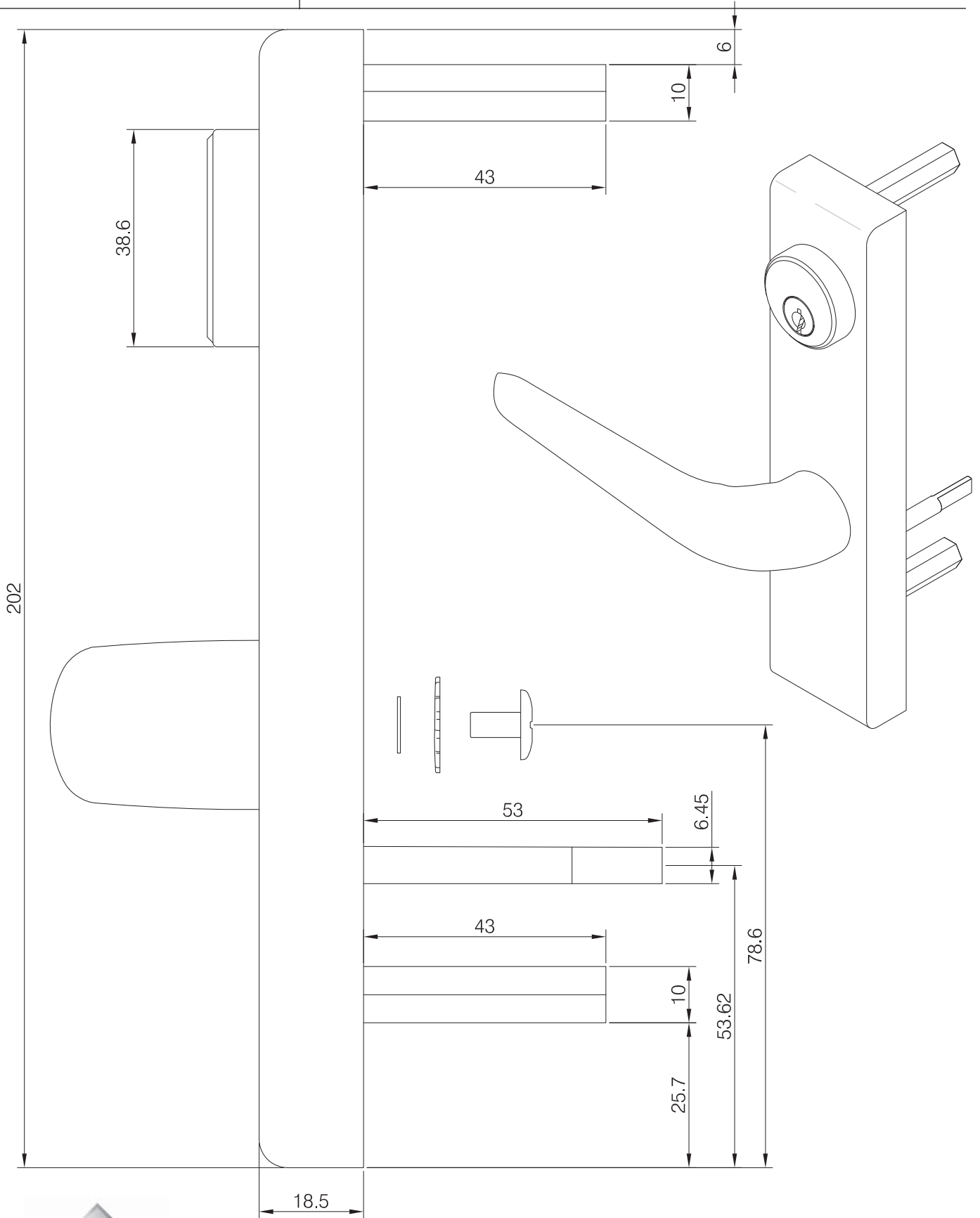

**The Parkside Group Ltd**

The Willow Centre  
17 Willow Lane, Mitcham, Surrey, CR4 4NX  
Tel: 020-8685 9685 Fax: 020-8646 5096  
Email: [axim@parksidegroup.co.uk](mailto:axim@parksidegroup.co.uk)  
Web Site: [www.axim.co.uk](http://www.axim.co.uk)

SCALE	NTS @A4
DATE	JULY 2017

For scaled technical or CAD drawings,  
please contact AXIM.

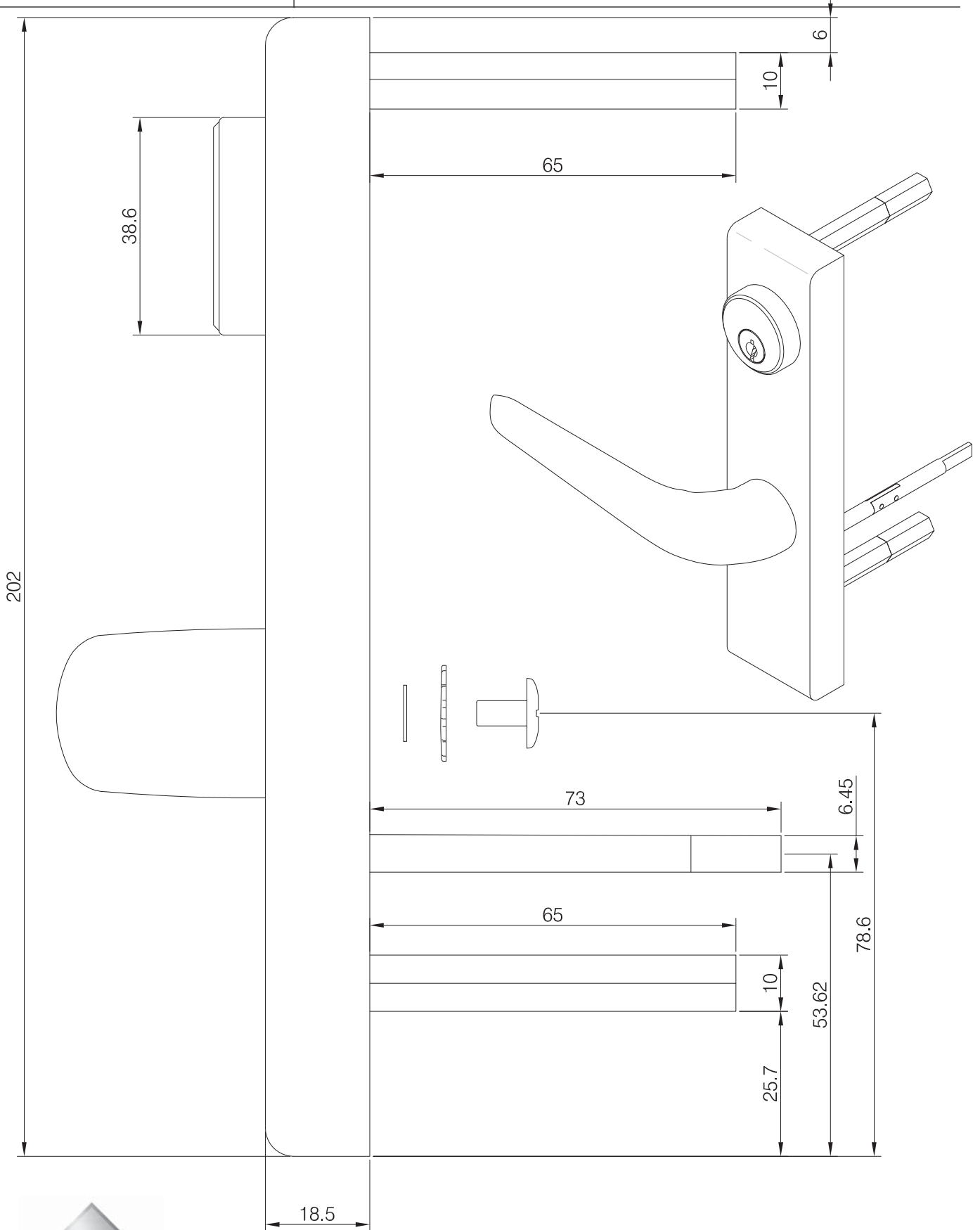

**The Parkside Group Ltd**

The Willow Centre  
17 Willow Lane, Mitcham, Surrey, CR4 4NX  
Tel: 020-8685 9685 Fax: 020-8646 5096  
Email: axim@parksidegroup.co.uk  
Web Site: www.axim.co.uk

SCALE	NTS @A4
DATE	JULY 2017

For scaled technical or CAD drawings,  
please contact AXIM.

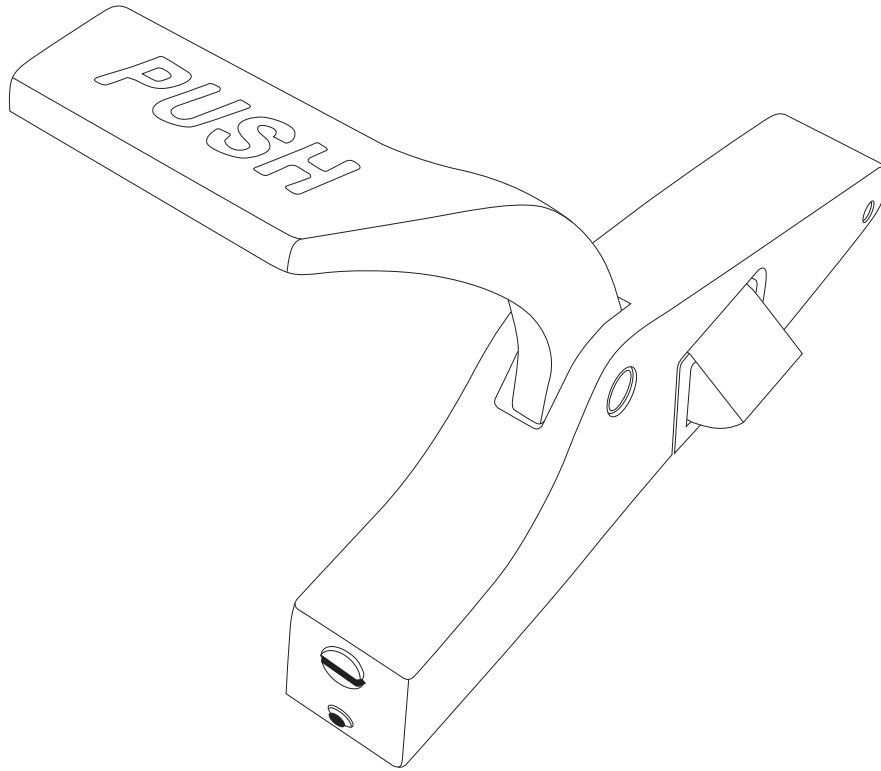

**RIM MOUNTED, PANIC EXIT DEVICE**

Available with standard mortice rim cylinder and lever allowing external access.

**MATERIAL FINISH**

Lever Handles are satin chrome finish to complement most door colours and are clearly marked 'PUSH'.

All Axim Panic Exit Hardware is supplied with comprehensive instructions and full size templates for ease of installation.

**ACCESSORIES**

Rim cylinder for access from outside

**Product codes:-**

- RC-795-AL** - 46 to 54mm - DOOR STILE - Silver
- RC-795-DU** - 46 to 54mm - DOOR STILE - Bronze
- RC-795-BK** - 46 to 54mm - DOOR STILE - Black
- RC-795-AL-S** - 46 to 54mm - DOOR STILE - Silver
- RC-797-AL** - 46 to 67mm - DOOR STILE - Silver
- RC-797-AL-S** - 46 to 67mm - DOOR STILE - Silver

**HAND OF DOOR**

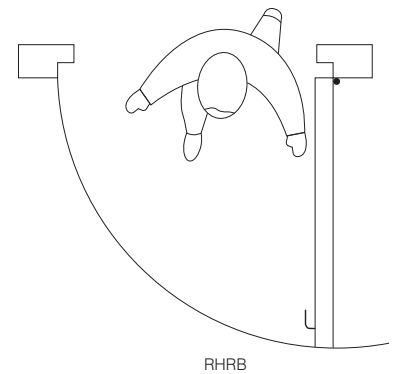
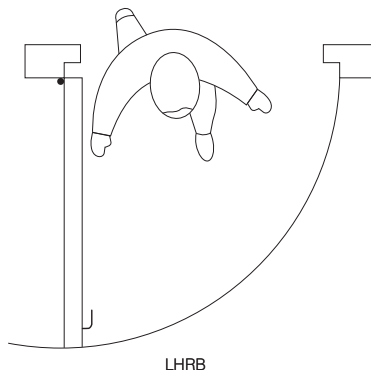

**GUARANTEE**

AXIM HANDLES ARE GUARANTEED FOR 12 MONTHS AGAINST DEFECT IN MATERIAL AND WORKMANSHIP. THIS GUARANTEE IS VOID IF THE PRODUCT HAS BEEN INCORRECTLY INSTALLED OR DAMAGED IN USE. CLAIMS FOR DAMAGE INCURRED OR WORK DONE THEREON WILL NOT BE ACCEPTED.

AXIM RESERVE THE RIGHT TO UPDATE ITS PRODUCT SPECIFICATIONS WITHOUT PRIOR NOTICE.



**The Parkside Group Ltd**

The Willow Centre  
17 Willow Lane, Mitcham, Surrey, CR4 4NX  
Tel: 020-8685 9685 Fax: 020-8646 5096  
Email: axim@parksidegroup.co.uk  
Web Site: www.axim.co.uk

SCALE	NTS @A4
DATE	JULY 2017
For scaled technical or CAD drawings, please contact AXIM.	

**L.H.R.B. Door shown**

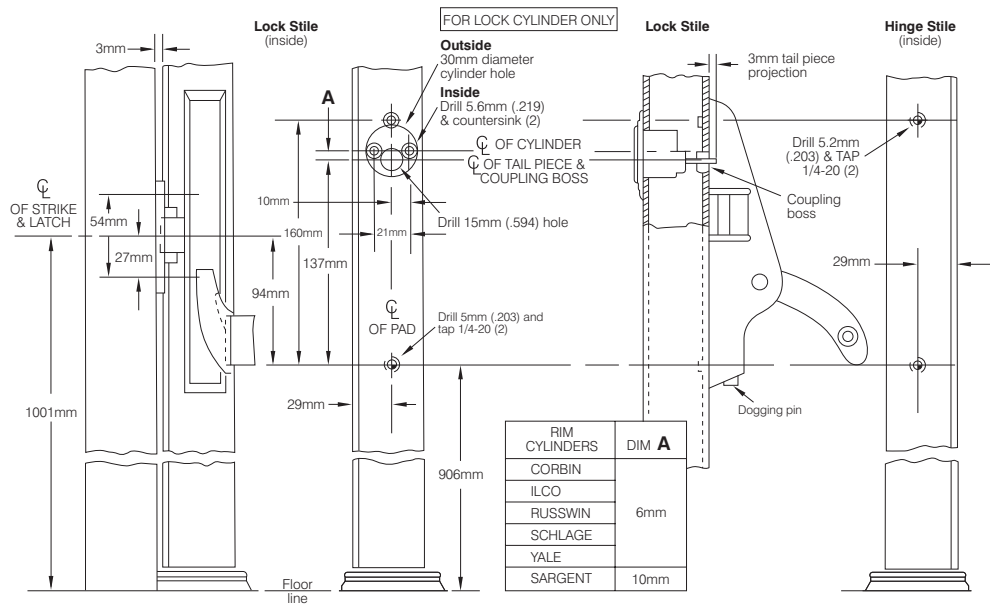
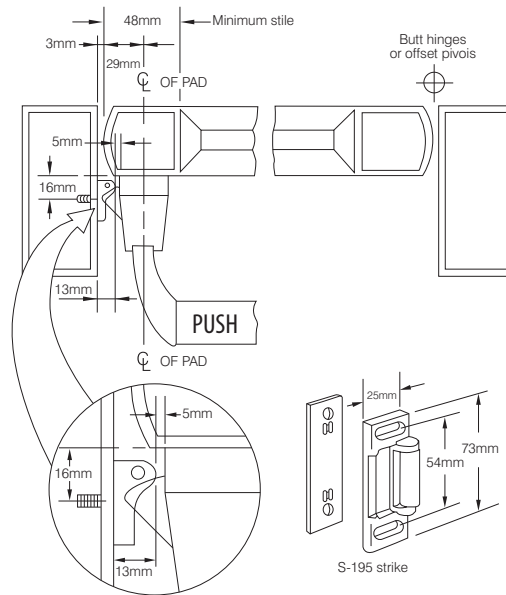

**Preparation**

1. Determine hand of door and prepare inside of lock and hinge stiles as shown.
2. If cylinder Key Lock is to be used, prepare inside and outside of lock stile as shown.
  - A Cut Spindle of Rim Cylinder to project thru the door 3mm Install Rim Cylinder and secure with (2) 12-24x29mm Machine Screws NOTE: Screw heads must be flush.
  - B Determine Function of Key Cylinder:
    - (1) STANDARD: Key removable in either locked or unlocked position. With Latch fully released, rotate Coupling Boss so index mark is up.
    - (2) NIGHT LATCH: Key removable in locked position only. With latch fully released, rotate Coupling Boss 90° towards hinge side.

3. Install (2) 1/4-20 Shoulder Studs on lock stile and position Exit Latch Pad over Studs and insert Cylinder Spindle into Coupling Boss. Place Pad over Studs and tighten 3 Socket Head Set Screws to secure in place.
4. Prepare lock jamb for Strike as shown and install using (2) #10 x 13mm Flat Head Self-threading Screws or #10 x 32mm All-purpose Screws.

**DOGGING EXIT DEVICE USING DOGGING PIN:**  
Fully depress Cross Bar and hold, push up Dogging Pin with screwdriver and rotate 90° in either direction.

**TO RELEASE EXIT DEVICE:**  
Hold Cross Bar down and rotate Dogging Pin with screwdriver in either direction until Dogging Pin releases.

**DOGGING EXIT DEVICE USING CYLINDER KEY:**  
Turn Key toward hinge side approximately 360°.

**TO RELEASE EXIT DEVICE:**  
Turn Key toward latch side approximately 360°.



**The Parkside Group Ltd**

The Willow Centre  
17 Willow Lane, Mitcham, Surrey, CR4 4NX  
Tel: 020-8685 9685 Fax: 020-8646 5096  
Email: axim@parksidegroup.co.uk  
Web Site: www.axim.co.uk

SCALE	NTS @A4
DATE	MARCH 2014
For scaled technical or CAD drawings, please contact AXIM.	

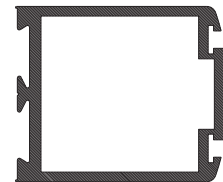

RC-795-AL Rim cylinder for use with 7095P panic exit device

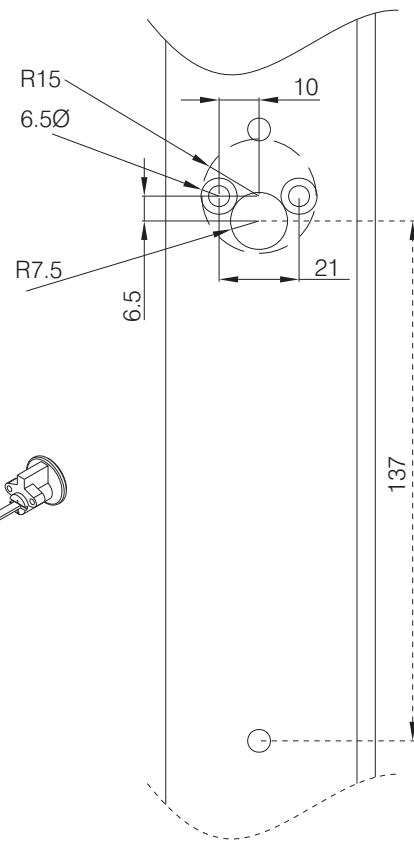
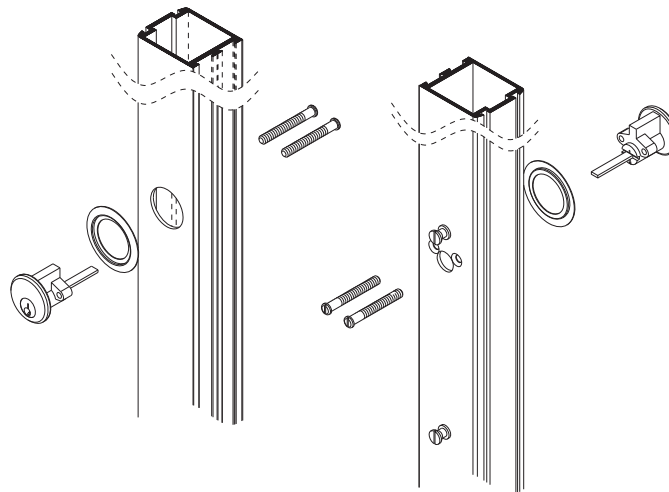

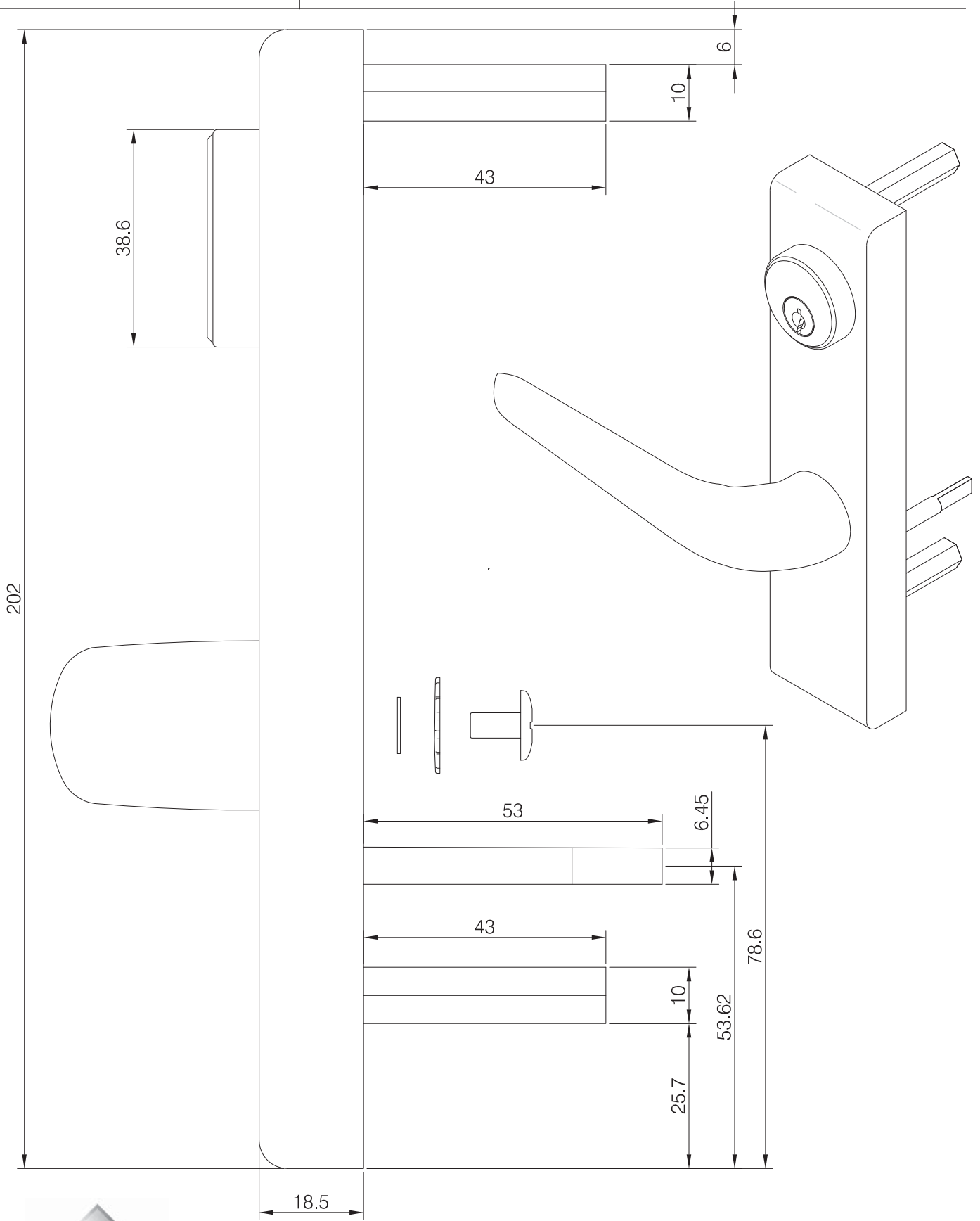

**The Parkside Group Ltd**

The Willow Centre  
17 Willow Lane, Mitcham, Surrey, CR4 4NX  
Tel: 020-8685 9685 Fax: 020-8646 5096  
Email: axim@parksidegroup.co.uk  
Web Site: www.axim.co.uk

SCALE	NTS @A4
DATE	JULY 2017
For scaled technical or CAD drawings, please contact AXIM.	

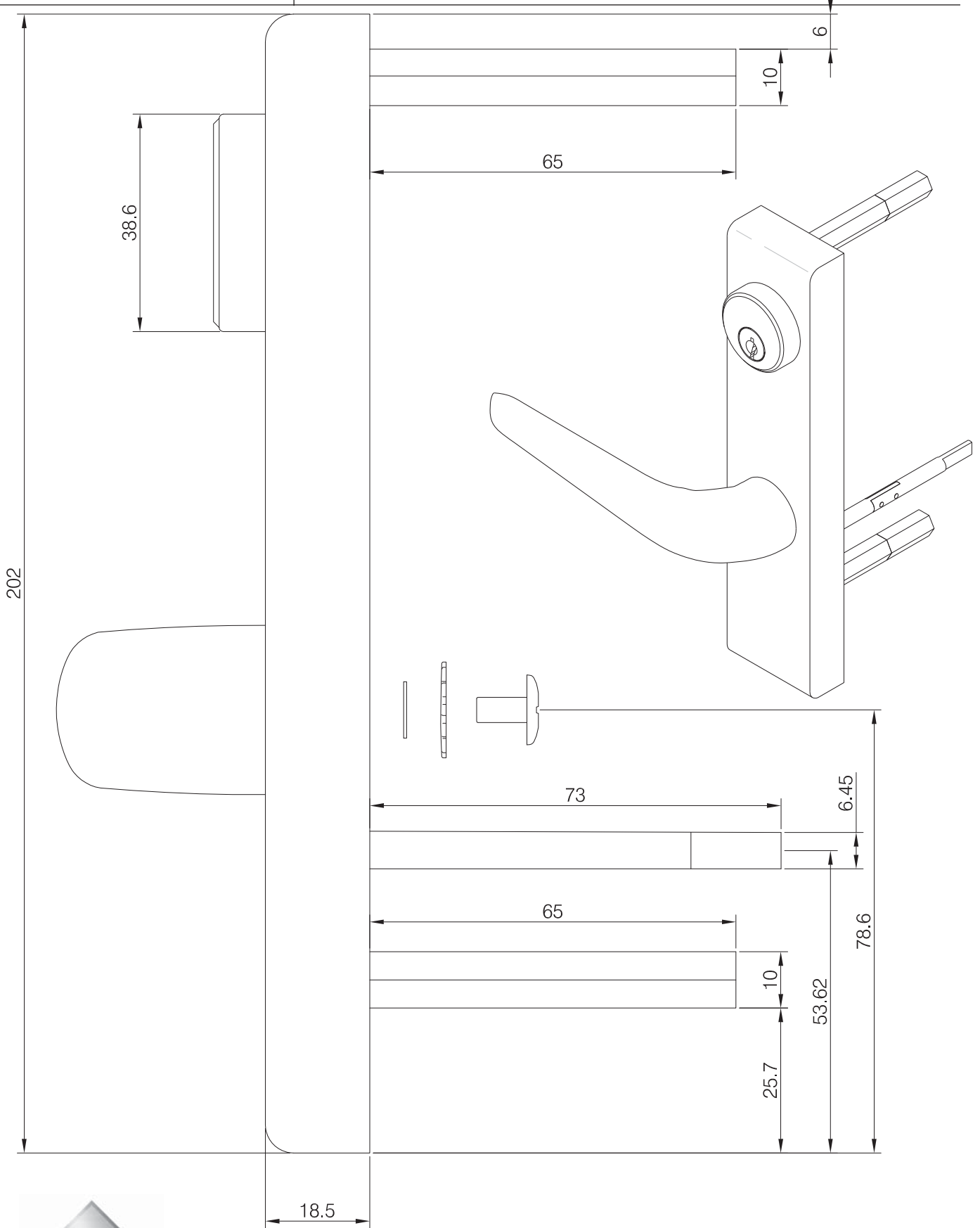

**The Parkside Group Ltd**

The Willow Centre  
17 Willow Lane, Mitcham, Surrey, CR4 4NX  
Tel: 020-8685 9685 Fax: 020-8646 5096  
Email: [axim@parksidegroup.co.uk](mailto:axim@parksidegroup.co.uk)  
Web Site: [www.axim.co.uk](http://www.axim.co.uk)

SCALE	NTS @A4
DATE	JULY 2017

For scaled technical or CAD drawings,  
please contact AXIM.

CONCEALED ROD, PANIC EXIT DEVICE

Heavy duty lever springs and internal mechanism for durable, smooth operation.  
Plated steel and stainless steel internal components.  
8.5mm diameter, steel locking rods with 16mm bolt throw.  
Bolt length adjustable ensuring correct alignment.  
Standard model suitable for door widths as narrow as 700mm and 2135 high. 300mm & 600mm coupling rods are available for taller doors.

Available with standard mortice rim cylinder and mounting pad allowing external access.  
Permanent bolt retention for easy access can be achieved with cylinder key from outside or hexagon key in the touch bar.  
Extruded aluminium touch bar, anodised finish with coloured alloy end caps to match.

All Axim panic exit hardware is supplied with comprehensive instructions and full size templates for ease of installation.

MODEL SELECTION

Determine the hand of the door using the diagram above and enter the correct designation after the series number.

Example:

**PR-7100-AL-LHRB**

**NOTE: Units are stocked in both right and left hand but are easily field reversible.**

ACCESSORIES

Extension rod with coupling for doors over 2135mm high (plated steel)

**REF: RE-712** - 300mm Extension rod

**RE-714** - 600mm Extension rod

Dogging pin

**DP-713** - Silver

Locking handles

**LH-725-AL** - 46mm DOOR STILE - Silver

**LH725-BK** - 46mm DOOR STILE - Black

**LH-730-AL** - 49mm DOOR STILE - Silver

**LH-740-AL** - 54mm DOOR STILE - Silver

**LH-745-AL** - 67mm DOOR STILE - Silver

Rim cylinder for access from outside

Product codes;

**RC-785-AL** - 46mm DOOR STILE - Silver

**RC-785-DU** - 46mm DOOR STILE - Bronze

**RC-785-BK** - 46mm DOOR STILE - Black

**RC-785-AL-S** - 46mm DOOR STILE - Silver

**RC-787-AL** - 49mm DOOR STILE - Silver

**RC-789-AL** - 54mm DOOR STILE - Silver

**RC-789-AL-S** - 54mm DOOR STILE - Silver

**RC-791-AL** - 67mm DOOR STILE - Silver

**RC-791-AL-S** - 67mm DOOR STILE - Silver

Cylinder mounting pad for above including fixings

Product codes;

**MP-786-AL** - 49mm DOOR STILE - Silver

**MP-786-DU** - 49mm DOOR STILE - Bronze

**MP-786-BK** - 49mm DOOR STILE - Black

**MP-780-AL** - 49mm DOOR STILE - Silver

**MP-790-AL** - 54mm DOOR STILE - Silver

**MP-792-AL** - 67mm DOOR STILE - Silver

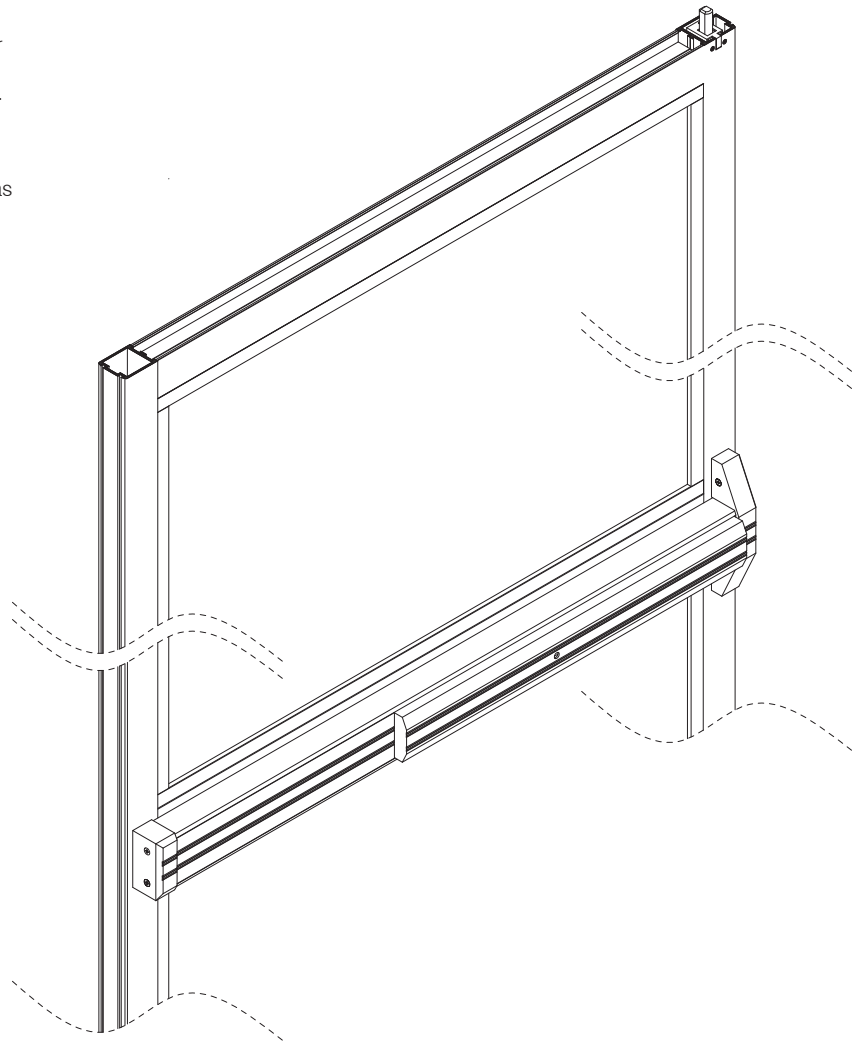

HAND OF DOOR

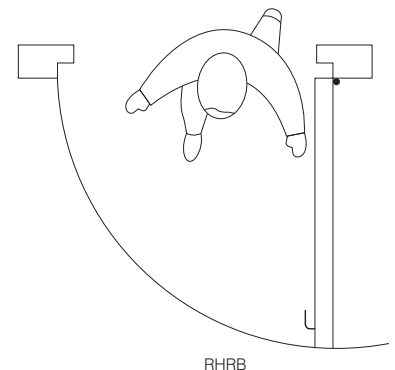
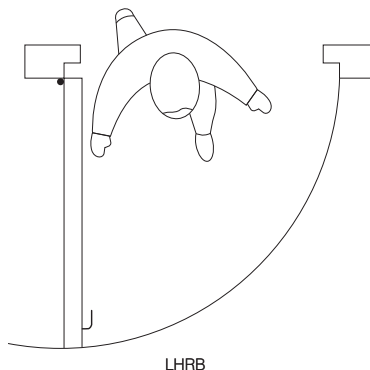

The Parkside Group Ltd

The Willow Centre  
17 Willow Lane, Mitcham, Surrey, CR4 4NX  
Tel: 020-8685 9685 Fax: 020-8646 5096  
Email: axim@parksidegroup.co.uk  
Web Site: www.axim.co.uk

SCALE NTS @A4

DATE AUGUST 2017

For scaled technical or CAD drawings, please contact AXIM.



TITLE	<b>CONCEALED ROD SOFT TOUCH BAR PR-7100 SERIES</b>	SHEET No. <b>4:27</b>
SUB TITLE	<b>CONCEALED ROD TOUCH BAR PANIC EXIT DEVICE PR-7100</b>	

Panic exit device,  
concealed vertical rod,  
42" flat touch bar

Aluminium PR-7100-AL  
Bronze PR-7100-DU  
Black PR-7100-BK

Extension rod with coupler  
(300mm extension) RE-712

Rim cylinder lock (supplied with 2 keys)  
Aluminium RC-785-AL  
Bronze RC-785-DU  
Black RC-785-BK

Rim cylinder lock keyed alike  
Aluminium RC-785-AL KA

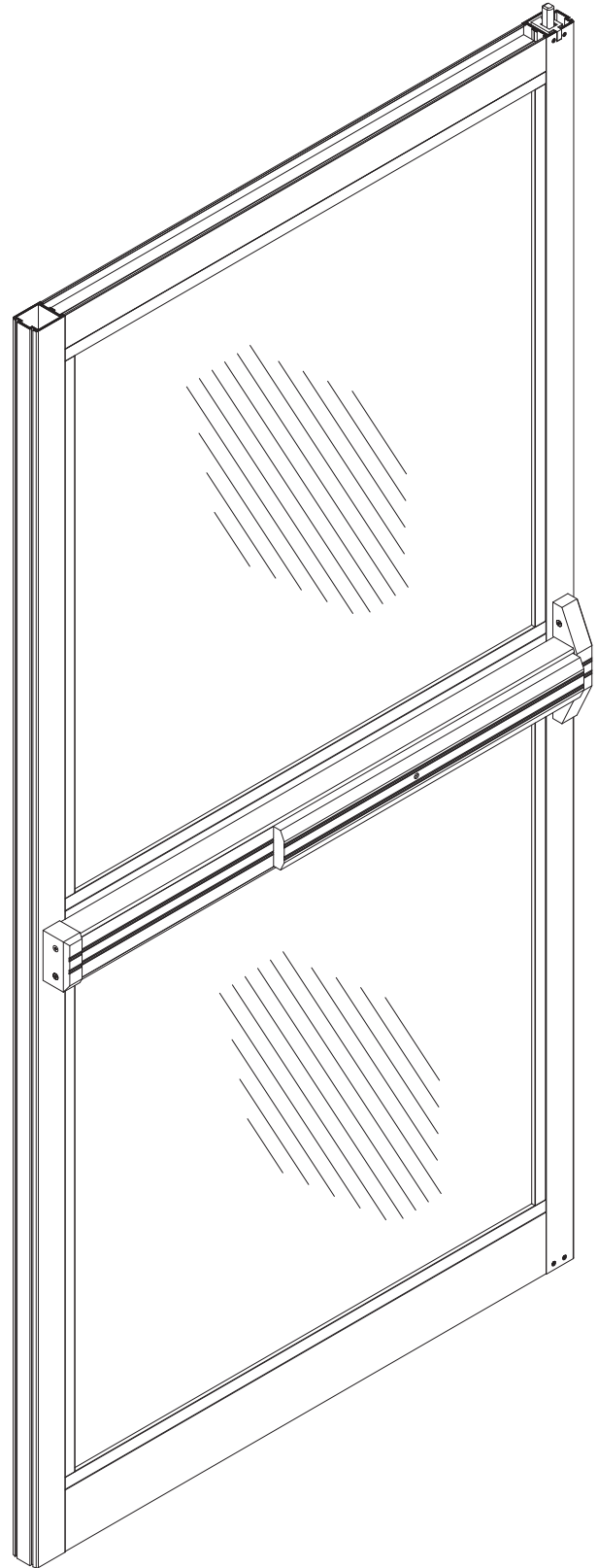

**The Parkside Group Ltd**

The Willow Centre  
17 Willow Lane, Mitcham, Surrey, CR4 4NX  
Tel: 020-8685 9685 Fax: 020-8646 5096  
Email: axim@parksidegroup.co.uk  
Web Site: www.axim.co.uk

SCALE	NTS @A4
DATE	MARCH 2014

For scaled technical or CAD drawings,  
please contact AXIM.

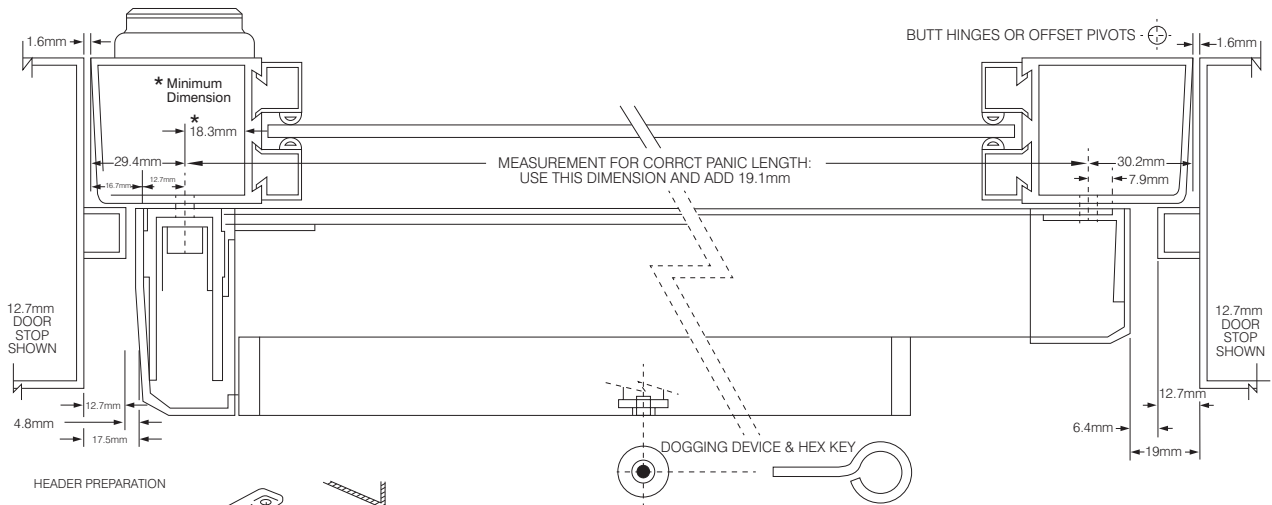

HEADER PREPARATION

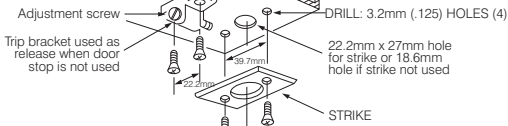

INSTALLATION INSTRUCTIONS

- Determine hand of door and prepare inside face of Lock and Hinge Stile as shown.
- NOTE: For Key Cylinder Only**  
If key cylinder is to be used, prepare inside and outside face of Lock Stile as shown.
- Insert Concealed Vertical Rod into Lock Stile and secure Centre Case Assembly with (2) 1/4-20 Hex Mounting Studs (short end for standard doors and long end for monumental door).
- NOTE: For Key Cylinder Only**  
If key cylinder is used, insert Cylinder in Mounting Pad and secure with Locking Ring. Remove Key, loosen (2) 1/4-20 Hex Mounting Studs, and secure Mounting pad with cylinder using (2) 8-32\* 49.2mm Flat Head Machine Screws. Re-tighten Hex Mounting Studs.
- Adjust length of top and bottom Actuating Bolts by turning in or out. When the Push Bar is fully depressed and Dogged, the Actuating Bolts should be slightly recessed from flush with the top and bottom of the door. Install top and bottom Bolt Guide with (6)#10\*12.7mm Flat head Self-Threading screws.  
**NOTE: Large Bevel** of Actuating Bolts must be inside and outside of stile.
- Measure for correct Panic Length. Measure distance from centreline of mounting holes on Lock and stiles of door as indicated AND ADD 19.1mm. Mark the measurement on back of the Panic form Latch End towards the Hinge End to be cut. Stuff a rag in the end of the Back Channel prior to cutting off excess length so that metal chips will not get into the mechanism. Protect the area to be cut and then cut to correct length.
- Drill (2) clearance holes for 12-24 machine screws in Hinge End of Back Channel as indicated. Attach Hinge End of Panic and Hinge End Mounting Bracket **LOOSELY** on Hinge Stile with (2) 12-24\*25.4mm Pan Head Thread Cutting Machine Screws and Lock Washers or (2) #12\*31.8mm Pan Head All-Purpose Screws and Lock Washers.
- Position Latch End of Panic over Hex Mounting Studs, Secure Latch End of Panic with (2) 1/4-20 Hex Nuts and Lock Washers, Tighten the (2) screws on the Hinge End Mounting Bracket, put crank into Latch End Housing, making sure that Link fits over end pin, insert screw into crank and tighten.
- Attach Latch End Cover and Hinge End Cover with (4) 8-32\*12.7mm Flat Head Thread Cutting Machine Screws.
- Prepare Header and Threshold Strikes as shown. If Header and Threshold Strikes are required, install using (4)#8\*9.5mm Flat Head Self-threading Screws or (4)#6\*25.4mm Flat Head All-purpose Screws.

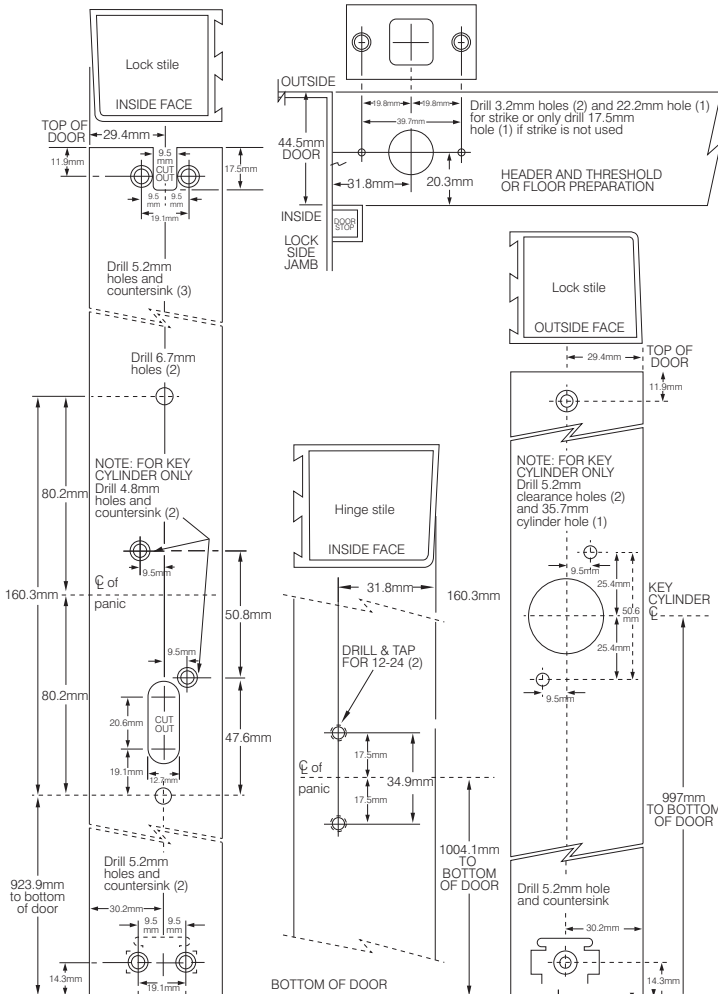

OPERATING INSTRUCTIONS

TO UNLOCK DOOR USING CYLINDER KEY:

Turn key approximately 1/4 turn **counterclockwise** and open the door, return key to centre and remove.

DOGGING USING CYLINDER KEY:

Open the door, fully depress Push Bar and hold, turn the key **clockwise** approximately 45°, return key to center and remove.

TO RELEASE CYLINDER KEY DOGGING:

Turn key **counterclockwise** approximately 45°, return key to centre and remove.

DOGGING USING DOGGING KEY:

Fully depress Push Bar and hold. Using Hex Dogging Key **push in** dogging device and turn **clockwise** approximately 1/2 turn.

TO RELEASE DOGGING KEY DOGGING:

Hold Touch Bar down. Using Hex Dogging Key **push in** Dogging Device and Turn **counterclockwise** approximately 1/2 turn. Dogging will be released.



The Parkside Group Ltd

The Willow Centre  
17 Willow Lane, Mitcham, Surrey, CR4 4NX  
Tel: 020-8685 9685 Fax: 020-8646 5096  
Email: axim@parksidegroup.co.uk  
Web Site: www.axim.co.uk

SCALE	NTS @A4
DATE	MARCH 2014

For scaled technical or CAD drawings, please contact AXIM.

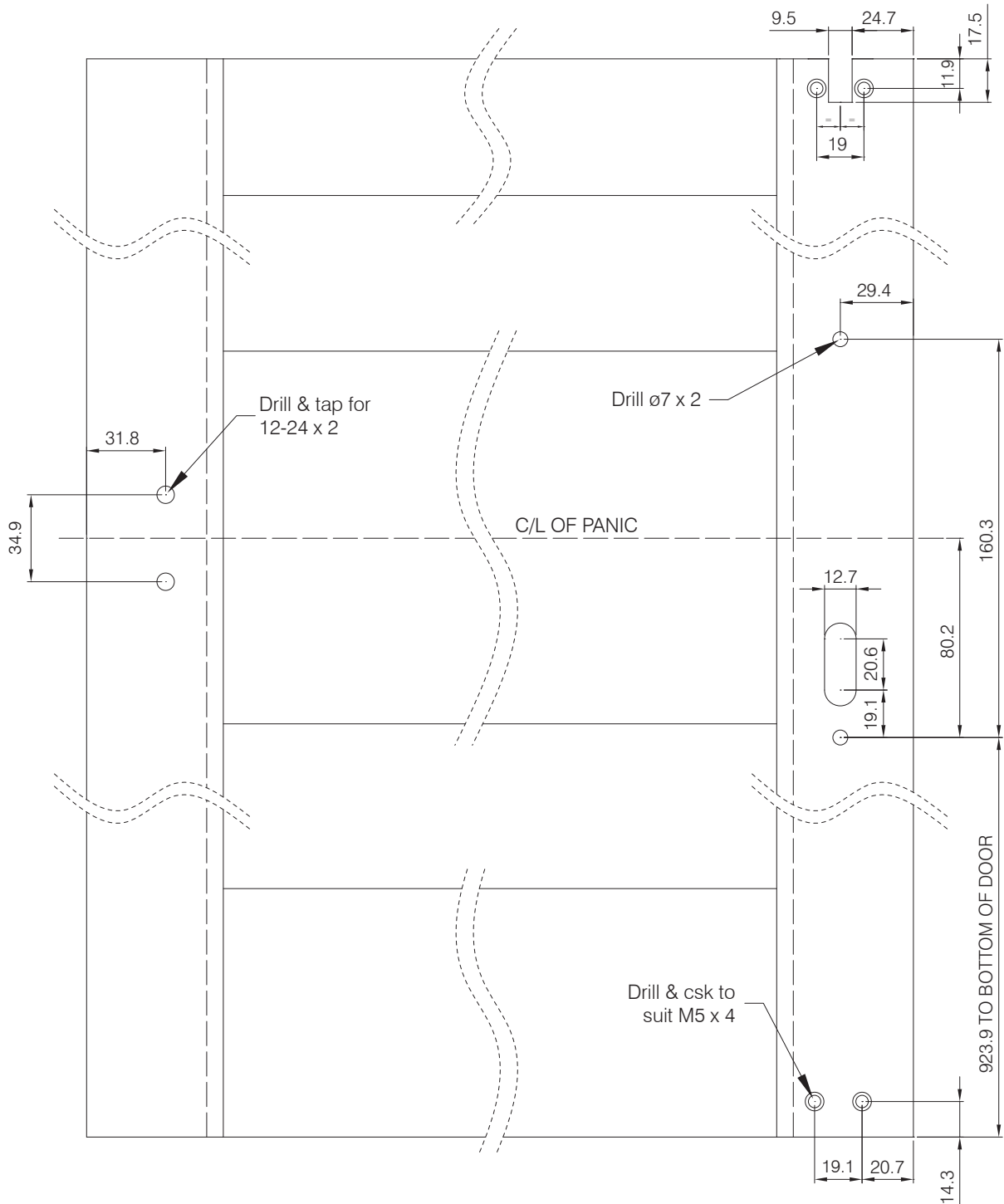
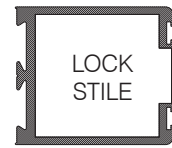
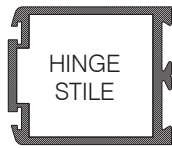

The Parkside Group Ltd

The Willow Centre  
17 Willow Lane, Mitcham, Surrey, CR4 4NX  
Tel: 020-8685 9685 Fax: 020-8646 5096  
Email: axim@parksidegroup.co.uk  
Web Site: www.axim.co.uk

SCALE NTS @A4

DATE JULY 2017

For scaled technical or CAD drawings,  
please contact AXIM.

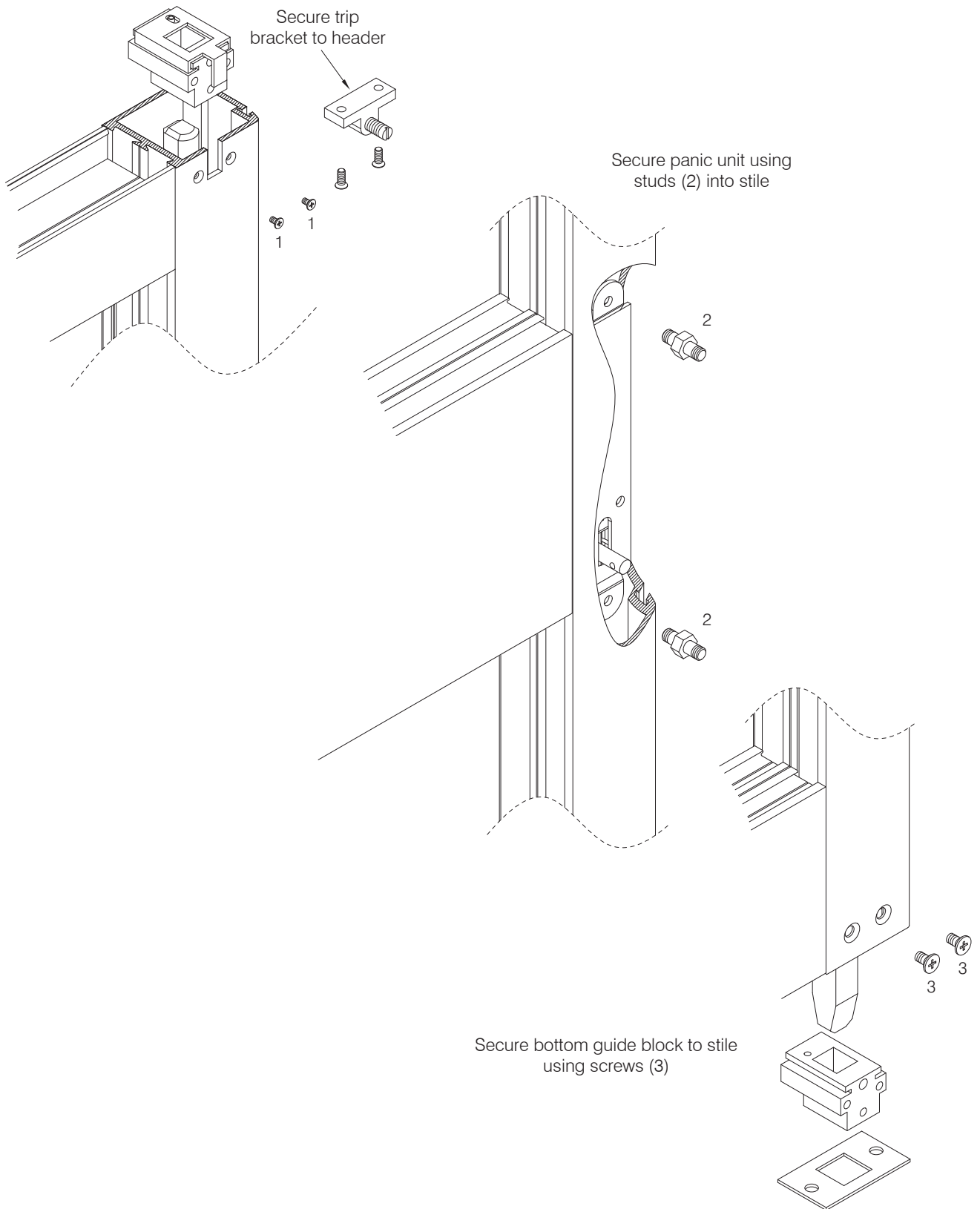

The Parkside Group Ltd

The Willow Centre  
17 Willow Lane, Mitcham, Surrey, CR4 4NX  
Tel: 020-8685 9685 Fax: 020-8646 5096  
Email: axim@parksidegroup.co.uk  
Web Site: www.axim.co.uk

SCALE NTS @A4

DATE MARCH 2014

For scaled technical or CAD drawings,  
please contact AXIM.

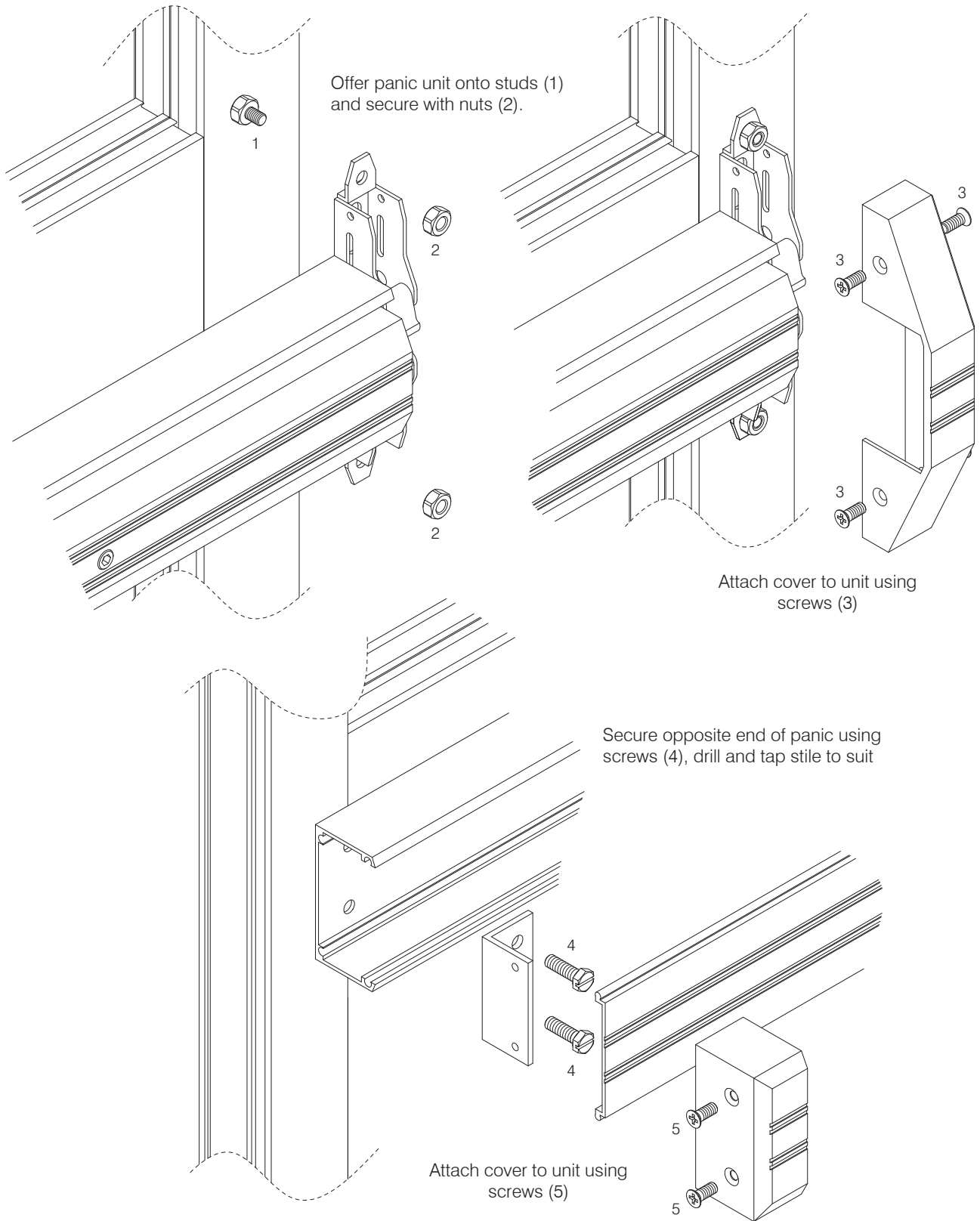

**The Parkside Group Ltd**

The Willow Centre  
17 Willow Lane, Mitcham, Surrey, CR4 4NX  
Tel: 020-8685 9685 Fax: 020-8646 5096  
Email: axim@parksidegroup.co.uk  
Web Site: www.axim.co.uk

SCALE NTS @A4

DATE MARCH 2014

For scaled technical or CAD drawings,  
please contact AXIM.

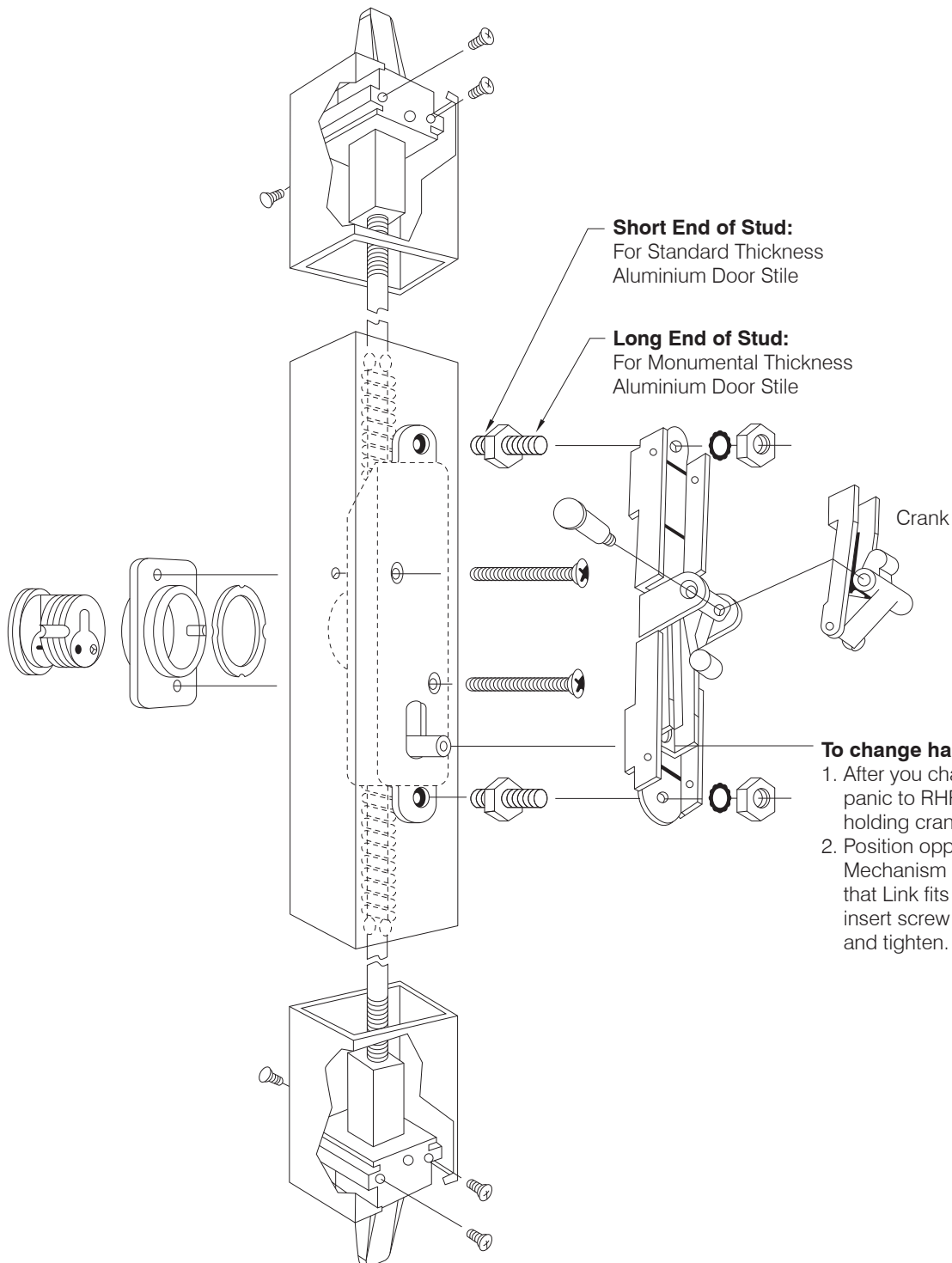

**To change hand of panic to RHRB**

1. After you change hand of panic to RHRB, remove screw holding crank in Mechanism.
2. Position opposite crank in Mechanism and make sure that Link fits over end Pin, insert screw in Mechanism and tighten.

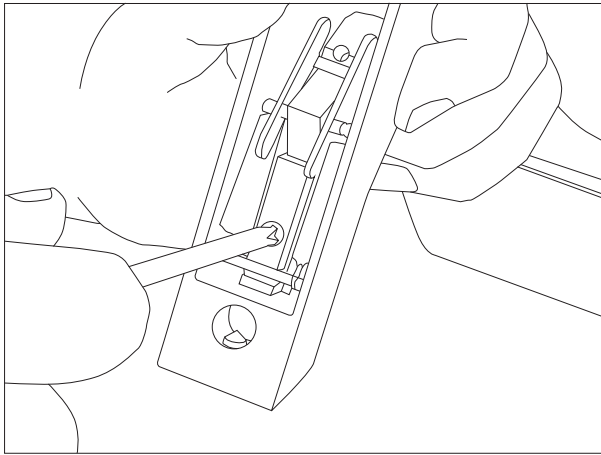

1) Remove securing screw in back of handle unit

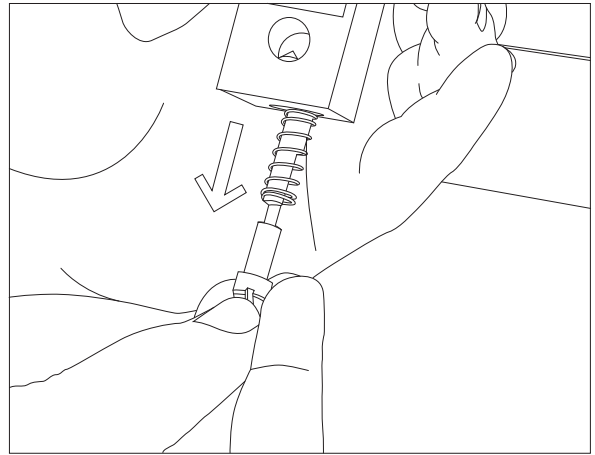

2) Once securing screw is removed existing pin should be ejected by internal spring

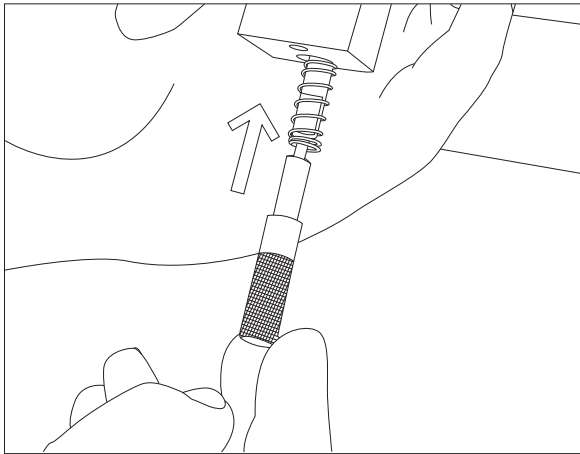

3) Replace existing pin with knurled pin (retaining original spring)

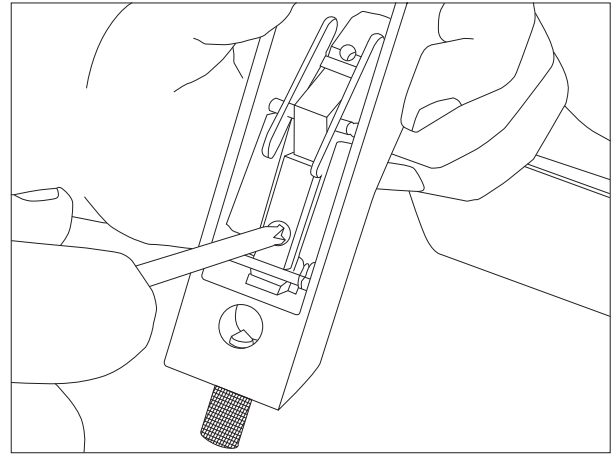

4) Replace securing screw holding knurled pin in far enough that notch on dogging pin can locate on securing screw

**LH-725 Locking handle**

Key Controlled Outside trim for use with PR7085, PR7085P, and PR7100 concealed rod Panic Devices.

Uses Axim screw in Mortice cylinder with MS type CAM.

Not handed. (Field reversible).

All Axim Panic Exit Hardware is supplied with comprehensive instructions and full size templates for ease of installation.

Handle rotation 45° anti-clockwise from centre.

OR

Handle rotation 45° clockwise from centre.

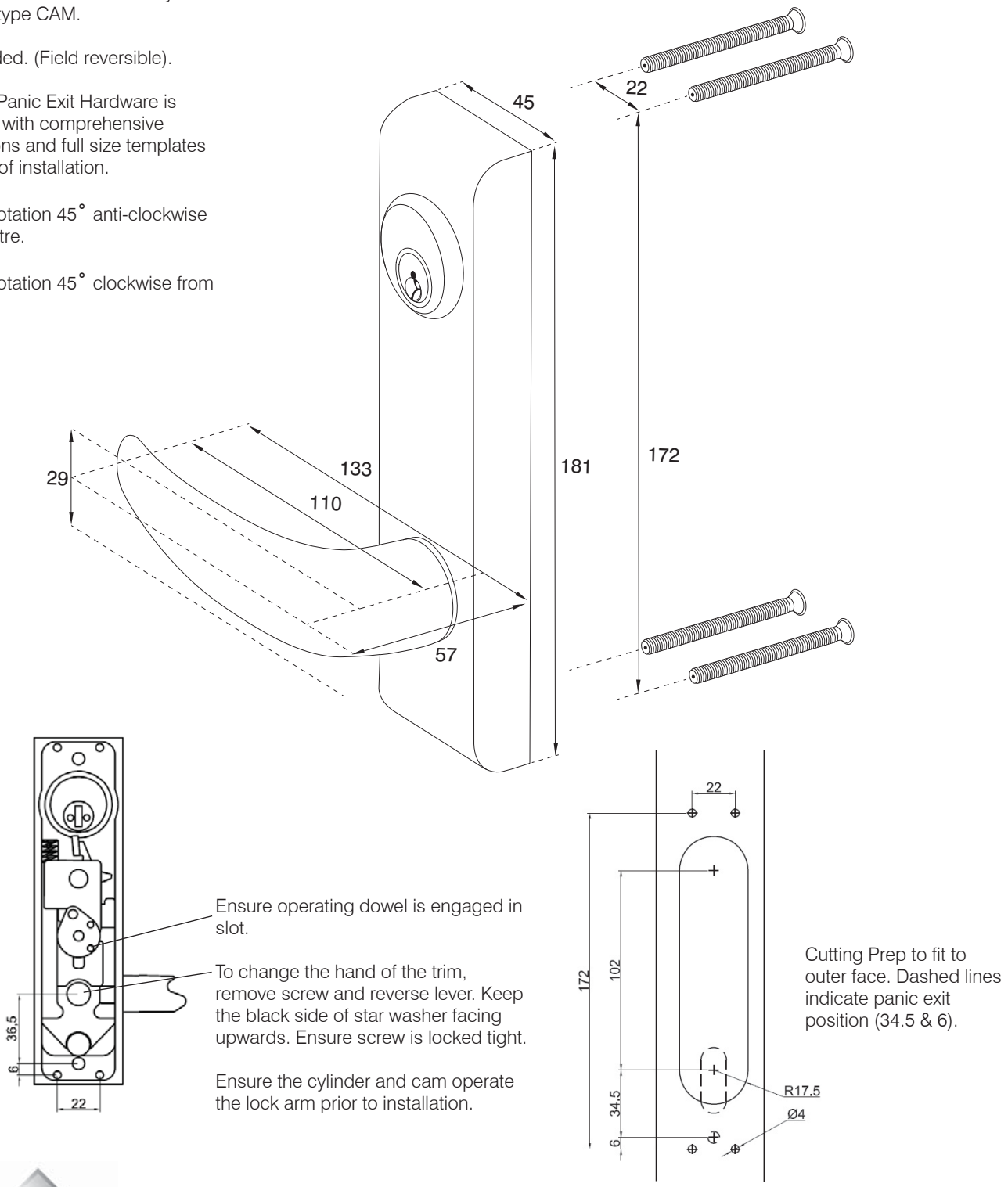

**The Parkside Group Ltd**  
The Willow Centre  
17 Willow Lane, Mitcham, Surrey, CR4 4NX  
Tel: 020-8685 9685 Fax: 020-8646 5096  
Email: axim@parksidegroup.co.uk  
Web Site: www.axim.co.uk

SCALE	NTS @A4
DATE	JULY 2017
For scaled technical or CAD drawings, please contact AXIM.	



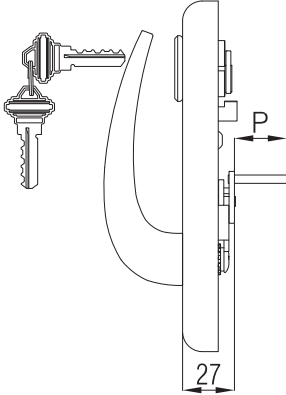

Locking Handle	Pin Length	Door Stile
LH-725	P = 6 mm	46mm
LH-730	P = 9 mm	49mm
LH-740	P = 14 mm	54mm
LH-745	P = 27 mm	67mm

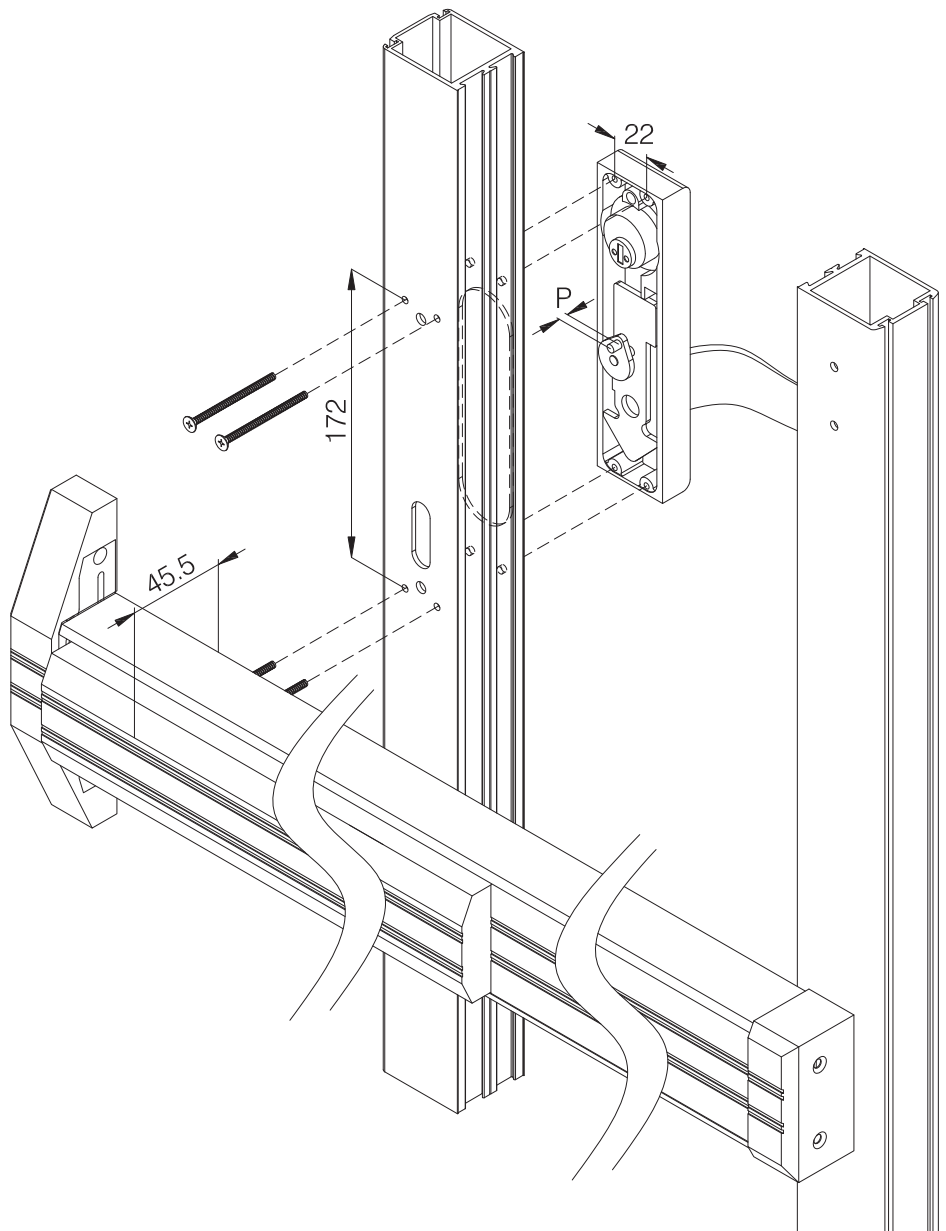
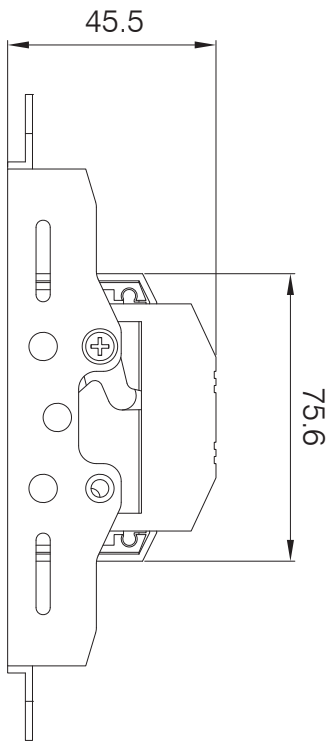

**The Parkside Group Ltd**

The Willow Centre  
17 Willow Lane, Mitcham, Surrey, CR4 4NX  
Tel: 020-8685 9685 Fax: 020-8646 5096  
Email: axim@parksidegroup.co.uk  
Web Site: www.axim.co.uk

SCALE NTS @A4

DATE AUGUST 2017

For scaled technical or CAD drawings,  
please contact AXIM.

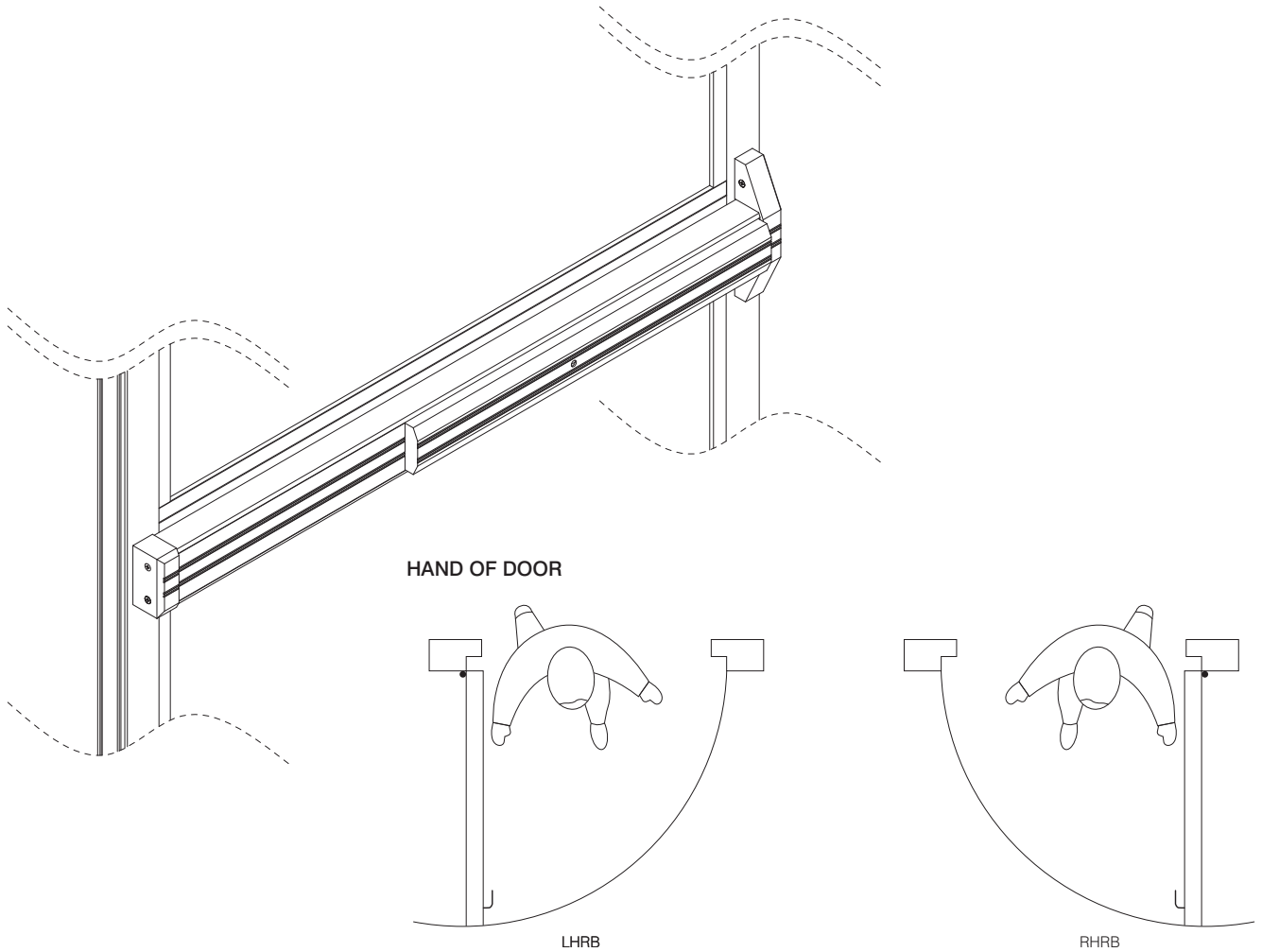

**RIM MOUNTED, PANIC EXIT DEVICE**

Heavy Duty Lever Springs for durable and smooth operation.

Standard model suitable for door widths as narrow as 700mm.

Available with standard mortice rim cylinder and lever, allowing external access.

Extruded aluminium touch bar, anodised finish with coloured alloy end caps to match.

All Axim Panic Exit Hardware is supplied with comprehensive instructions and full size templates for ease of installation.

**MODEL SELECTION**

Determine the hand of the door using the above diagram and enter the correct designation after the series number.

**Example:  
PR7300-AL-LHRB**

**ACCESSORIES**

Rim cylinder for access from outside  
**RC-795-AL** - 46mm to 54mm DOOR STILE- Silver  
**RC-795-DU** - 46mm to 54mm DOOR STILE- Bronze  
**RC-795-BK** - 46mm to 54mm DOOR STILE- Black  
**RC-797-AL** - 46mm to 67mm DOOR STILE - Silver  
**RC-795-AL-S** - 46mm to 54mm DOOR STILE - Silver  
**RC-797-AL-S** - 46mm to 67mm DOOR STILE - Silver

Locking handle  
**LH-750-AL** - 46mm DOOR STILE - Silver  
**LH-755-AL** - 67mm DOOR STILE - Silver

**SUGGESTED SPECIFICATION**

Rim Mounted Panic Exit devices with touch bar fitted to inside face of the door. Door shall be latched except during operation cycle or held open using cylinder key or when touch bar is locked down with hexagonal dogging key.  
 Operating Touch Bar and housing not to exceed 66mm projection.  
 All mounting screws to be concealed.  
 Handles and mechanism will be fitted with heavy duty springs for durability.  
 Ref: AXIM PR-7300 (Hand as specified)

**GUARANTEE**

AXIM HANDLES ARE GUARANTEED FOR 12 MONTHS AGAINST DEFECT IN MATERIAL AND WORKMANSHIP. THIS GUARANTEE IS VOID IF THE PRODUCT HAS BEEN INCORRECTLY INSTALLED OR DAMAGED IN USE. CLAIMS FOR DAMAGE INCURRED OR WORK DONE THEREON WILL NOT BE ACCEPTED.  
 AXIM RESERVE THE RIGHT TO UPDATE ITS PRODUCT SPECIFICATIONS WITHOUT PRIOR NOTICE.



**The Parkside Group Ltd**

The Willow Centre  
 17 Willow Lane, Mitcham, Surrey, CR4 4NX  
 Tel: 020-8685 9685 Fax: 020-8646 5096  
 Email: axim@parksidegroup.co.uk  
 Web Site: www.axim.co.uk

SCALE	NTS @A4
DATE	JULY 2017
For scaled technical or CAD drawings, please contact AXIM.	

Panic exit device - concealed vertical rod:  
**PR-7300-AL** - 42" flat touch bar (non handed) - Silver

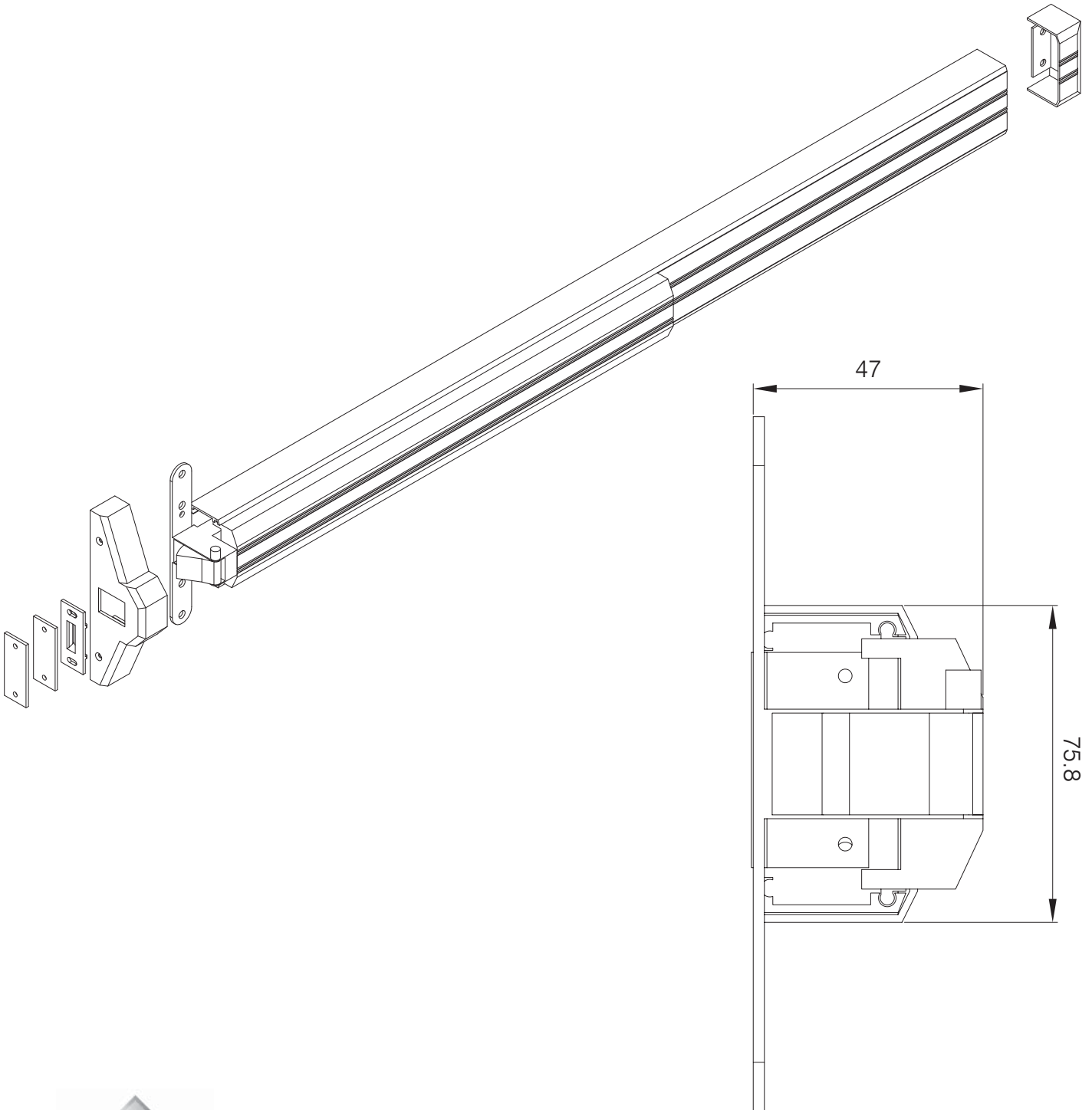

**The Parkside Group Ltd**

The Willow Centre  
17 Willow Lane, Mitcham, Surrey, CR4 4NX  
Tel: 020-8685 9685 Fax: 020-8646 5096  
Email: axim@parksidegroup.co.uk  
Web Site: www.axim.co.uk

SCALE	NTS @A4
DATE	AUGUST 2017

For scaled technical or CAD drawings,  
please contact AXIM.

**HOLLOW METAL DOORS – WITH REINFORCEMENT  
INSTALLATION INSTRUCTIONS**

- Determine hand of door and prepare inside face of Lock and Hinge Side as shown.
- NOTE: For Key Cylinder Only**  
If key cylinder is to be used, prepare inside and outside face of Lock Stile of door as shown. Cut spindle of Rim Cylinder to project thru the door 4mm. Install Rim Cylinder and secure with (2) 12-24 Fillister Head Machine Screws.  
**NOTE: Cut off excess screw length at break-off points as required.**
- Measure for correct Panic length. Measure distance from centreline of mounting holes on Lock and Hinge side of door as indicated AND ADD 22.2mm. Mark the measurement on back of the Panic from Latch End towards the Hinge End to be cut. Stuff a rag in the end of the Back Channel prior to cutting off excess length so that metal chips will not get into the mechanism. Protect the area to be cut and then cut to correct length.
- Drill (2) clearance holes for 12-24 Machine Screws and Hinge End of Back Channel as indicated. Attach Hinge End of Panic and Hinge End Mounting Bracket LOOSLEY on Hinge Side with (2) 12-24\*25.4mm Pan Head Thread Cutting Machine Screws and Lock Washers or (2)#12\*31.8mm Pan Head All-Purpose Screws and Lock Washers.
- Install (2) 1/4-20 Shoulder Studs on Lock Side. Position Latch End of Panic over Hex Mounting Studs. Secure with (2) 1/4-20 Hex Nuts and Lock Washers; also with (4) 12-24\*25.4mm Pan Head Thread Cutting Machine Screws and Lock Washers or (4) 12-24\*25.4mm Pan Head All-Purpose

- Screws and Lock Washers. Tighten the (2) screws on the Hinge End Mounting Bracket.
- NOTE:** If Key Cylinder is used, Cylinder Spindle must be inserted into Coupling Boss prior to fastening Latch End on door.
- Attach Latch End Cover and Hinge End Cover with (4) 8-32\*12.7mm Flat Head Thread Cutting Machine Screws.
  - Place Strike on Lock Jamb as shown, (Centred on Latch). Mark and Drill Jamb for (2) 10-24\*19.1mm Pan Head Thread Cutting Machine Screws and Lock Washers or (2)#10\*31.8mm Pan Head All Purpose Screws and Lock Washers.
  - Position Latch End of Panic over Hex Mounting Studs, Secure Latch End of Panic with (2) 1/4-20 Hex Nuts and Lock Washers, Tighten the (2) screws on the Hinge End Mounting Bracket, put crank into Latch End Housing, making sure that Link fits over end pin, insert screw into crank and tighten.
  - Attach Latch End Cover and Hinge End Cover with (4) 8-32\*12.7mm Flat Head Thread Cutting Machine Screws.  
**NOTE:** Use Spacers provided if required.

**HOLLOW METAL AND WOOD DOORS – WITHOUT REINFORCEMENT  
INSTALLATION INSTRUCTIONS**

- Determine hand of door and prepare inside face of Lock and Hinge Side as shown.
- NOTE: For Key Cylinder Only**  
If key cylinder is to be used, prepare inside and outside face of Lock Stile of door as shown. Cut spindle of Rim Cylinder to project thru the door 4mm. Install Rim Cylinder and secure with (2) 12-24 Fillister Head Machine Screws.  
**NOTE: Cut off excess screw length at break-off points as required.**
- Measure for correct Panic length. Measure distance from centreline of mounting holes on Lock and Hinge Side of door as indicated AND ADD 22.2mm. Mark the measurement on the back of the Panic from Latch End towards the Hinge End to be cut. Stuff a rag in the end of the Back Channel prior to cutting off excess length so that metal chips will not get into the mechanism. Protect the area to be cut and then cut to correct length.
- Drill (2) clearance holes for 12-24 Machine Screws in Hinge End of Back Channel as indicated. Attach Hinge End of Panic and Hinge End Mounting Bracket LOOSLEY on Hinge side with (2) 12-24\*25.4mm Pan Head Thread Cutting Machine Screws and Lock Washers with 12-24\*42.9mm Sex Nuts or (2)#12\*31.8mm Pan Head All-Purpose Screws and Lock Washers. Tighten the (2) screws on the Hinge End Mounting Bracket.  
**NOTE:** If Key Cylinder is used, Cylinder Spindle must be inserted into Coupling Boss prior to fastening Latch End on door.
- Attach Latch End Cover and Hinge End Cover with (4) 8-32\*12.7mm Flat Head Thread Cutting Machine Screws.
- Place Strike on Lock Jamb as shown, (Centred on Latch). Mark and Drill Jamb for (2) 10-24\*19.1mm Pan Head Thread Cutting Machine Screws and Lock Washers or (2)#10\*31.8mm Pan Head All Purpose Screws and Lock Washers.  
**NOTE:** Use Spacers provided if required.

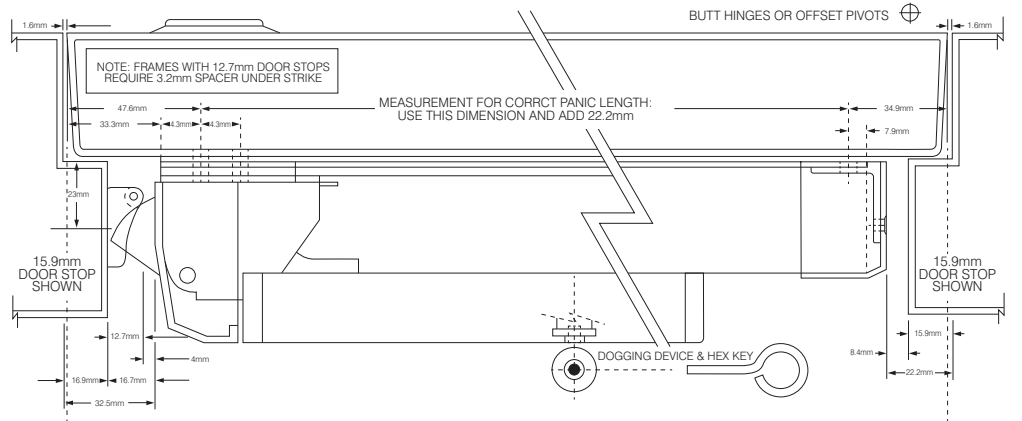

**OPERATING INSTRUCTIONS**

**TO UNLOCK DOOR USING CYLINDER KEY:**

Turn key approximately 1/4 turn in either direction and open door, return key to centre and remove. **NOTE:** Cylinder Key WILL NOT dog unit. Dogging is from inside with Hex Dogging Key only.

**DOGGING USING DOGGING KEY:**

Fully depress Touch Bar and hold. Using Hex Dogging Key **push in** Dogging Device and turn **clockwise** approximately 1/2 turn.

**TO RELEASE DOGGING KEY DOGGING:**

Hold Touch Bar down. Using Hex Dogging Key **push in** Dogging Device and turn **counterclockwise** approximately 1/2 turn. Dogging will be released.

**HOLLOW METAL DOORS – WITH REINFORCEMENT**

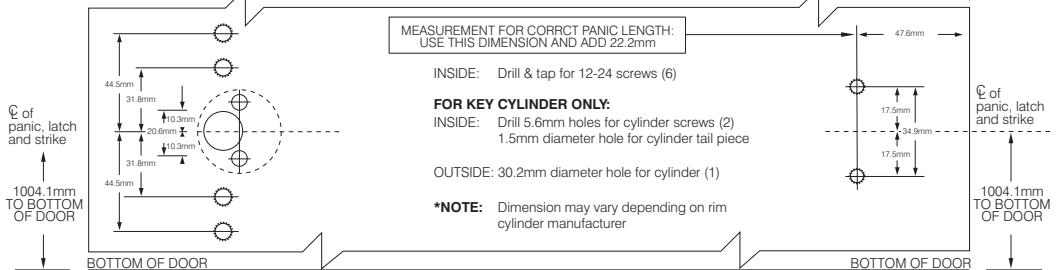

**HOLLOW METAL AND WOOD DOORS – WITHOUT REINFORCEMENT**

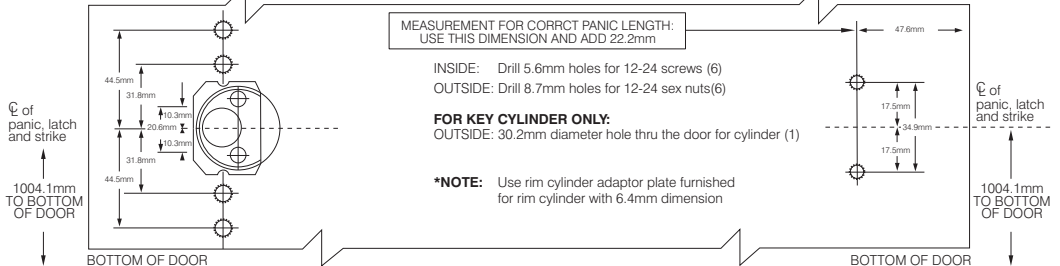

**The Parkside Group Ltd**

The Willow Centre  
17 Willow Lane, Mitcham, Surrey, CR4 4NX  
Tel: 020-8685 9685 Fax: 020-8646 5096  
Email: axim@parksidegroup.co.uk  
Web Site: www.axim.co.uk

SCALE	NTS @A4
DATE	MARCH 2014

For scaled technical or CAD drawings, please contact AXIM.

**INSTALLATION INSTRUCTIONS**

- Determine hand of door and prepare inside face of Lock and Hinge Stile as shown.
- NOTE: For Key Cylinder Only**  
If key cylinder is to be used, prepare inside and outside face of Lock Stile as shown. Cut spindle of Rim Cylinder to project thru the door 4mm. Install Rim Cylinder and secure with (2) 12-24 Fillister Head Machine Screws.  
**NOTE: Cut off excess Screw length at break-off points as required.**
- Measure for correct Panic length. Measure distance from centreline of mounting holes on Lock and Hinge Stiles of door as indicated AND ADD 22.2mm. Mark the measurement on the back of the Panic from Latch End towards the Hinge End to be cut. Stuff a rag in the end of the Back Channel prior to cutting off excess length so that metal chips will not get into the mechanism. Protect the area to be cut and then cut to correct length.
- Drill (2) clearance holes for 12-24 Machine Screws in Hinge End of Back Channel as indicated. Attach Hinge End of Panic and Hinge End Mounting Brack LOOSLEY on Hinge

- Stile with (2) 12-24\*2525.4mm Pan Head Thread Cutting Machine Screws and Lock Washers or (2) #12-24\*25.4mm Pan Head All-purpose Screws and Lock Washers.
- Install (2) 1/4-20 Shoulder Studs on Lock Stile. Position Latch End of Panic over Hex Mounting Studs. Secure with (2) 1/4-20 Hex Nuts and Lock Washers; also with (4) 12-24\*25.4mm Pan Head Thread Cutting Machine Screws and Lock Washers or (4) #12\*31.8mm Pan Head All-Purpose Screws and Lock Washers. Tighten the (2) screws on the Hinge End Mounting Bracket.
  - NOTE:** If Key Cylinder is used, Cylinder Spindle must be inserted into Coupling Boss prior to fastening Latch End on Lock Stile.
  - Attach Latch End Cover and Hinge End Cover with (4) 8-32\*12.7mm Flat Head Thread Cutting Machine Screws.
  - Place Strike on Lock Jamb as shown, (Centred on Latch). Mark and Drill Jamb for (2) 10-24\*19.1mm Pan Head Thread Cutting Machine Screws and Lock Washers or (2)#10\*31.8mm Pan Head All Purpose Screws and Lock Washers.  
**NOTE:** 3.2mm Spacer must be used under Strike on a Frame. Use extra Spacer provided if required.

**OPERATING INSTRUCTIONS**

**TO UNLOCK DOOR USING CYLINDER KEY:**  
Turn key approximately 1/4 turn in either direction and open door, return key to centre and remove.  
**NOTE:** Cylinder Key WILL NOT dog unit. Dogging is from inside with Hex Dogging Key only.

---

**DOGGING USING DOGGING KEY:**  
Fully depress Touch Bar and hold. Using Hex Dogging Key **push in** Dogging Device and turn **clockwise** approximately 1/2 turn.

**TO RELEASE DOGGING KEY DOGGING:**  
Hold Touch Bar down. Using Hex Dogging Key **push in** Dogging Device and turn **counterclockwise** approximately 1/2 turn. Dogging will be released.

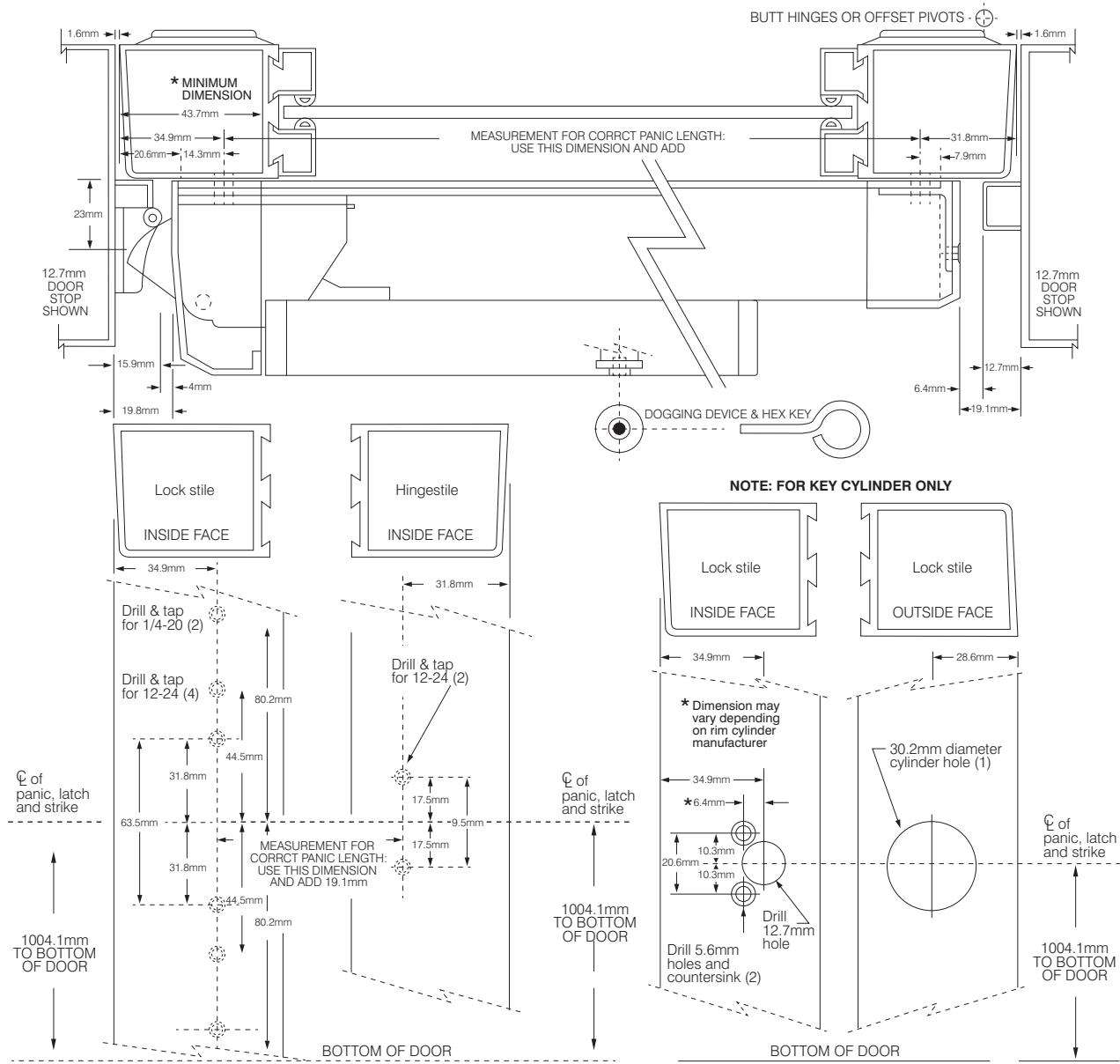

**The Parkside Group Ltd**  
The Willow Centre  
17 Willow Lane, Mitcham, Surrey, CR4 4NX  
Tel: 020-8685 9685 Fax: 020-8646 5096  
Email: axim@parksidegroup.co.uk  
Web Site: www.axim.co.uk

SCALE	NTS @A4
DATE	MARCH 2014
For scaled technical or CAD drawings, please contact AXIM.	

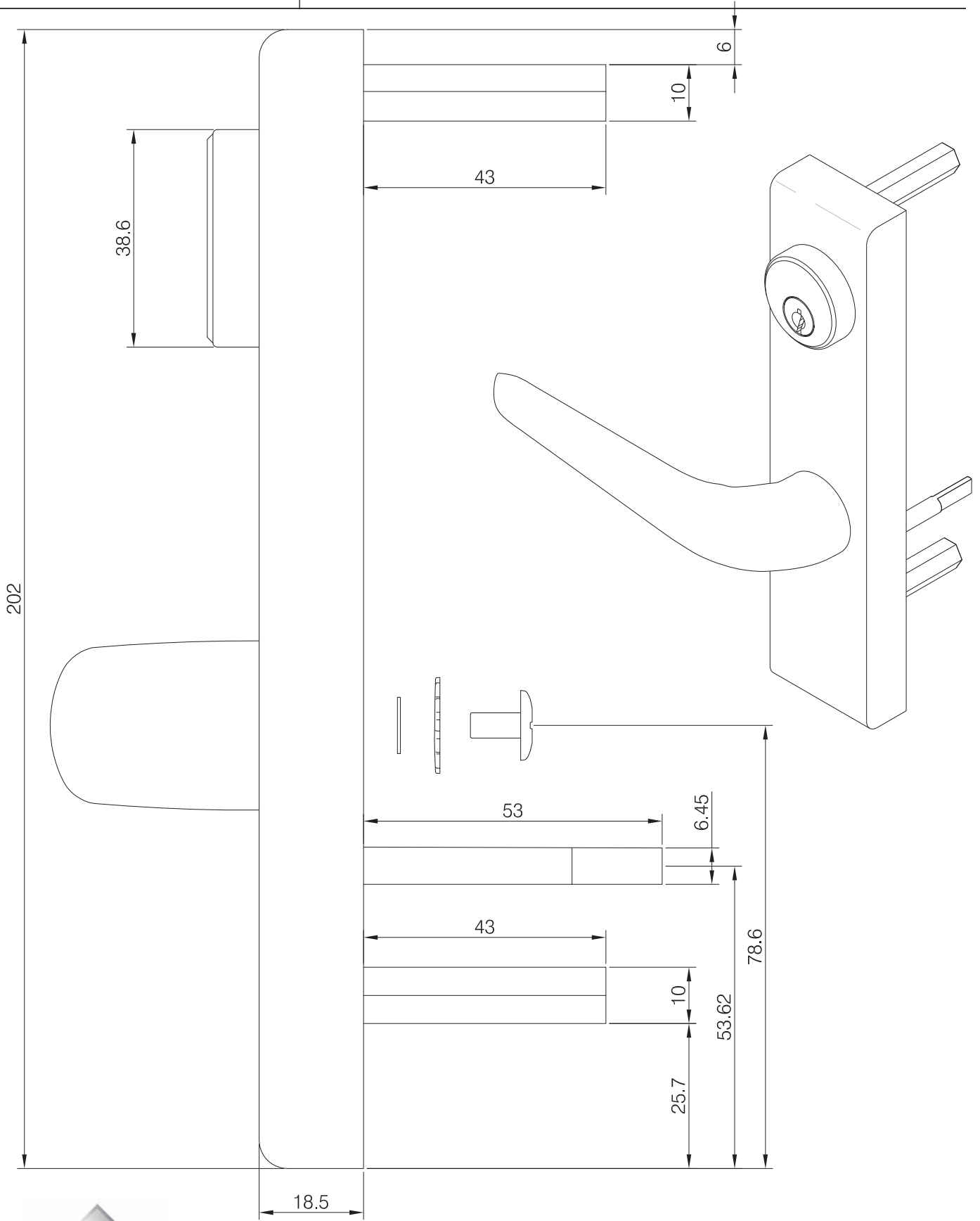

**The Parkside Group Ltd**  
 The Willow Centre  
 17 Willow Lane, Mitcham, Surrey, CR4 4NX  
 Tel: 020-8685 9685 Fax: 020-8646 5096  
 Email: axim@parksidegroup.co.uk  
 Web Site: www.axim.co.uk

SCALE	NTS @A4
DATE	JULY 2017
For scaled technical or CAD drawings, please contact AXIM.	

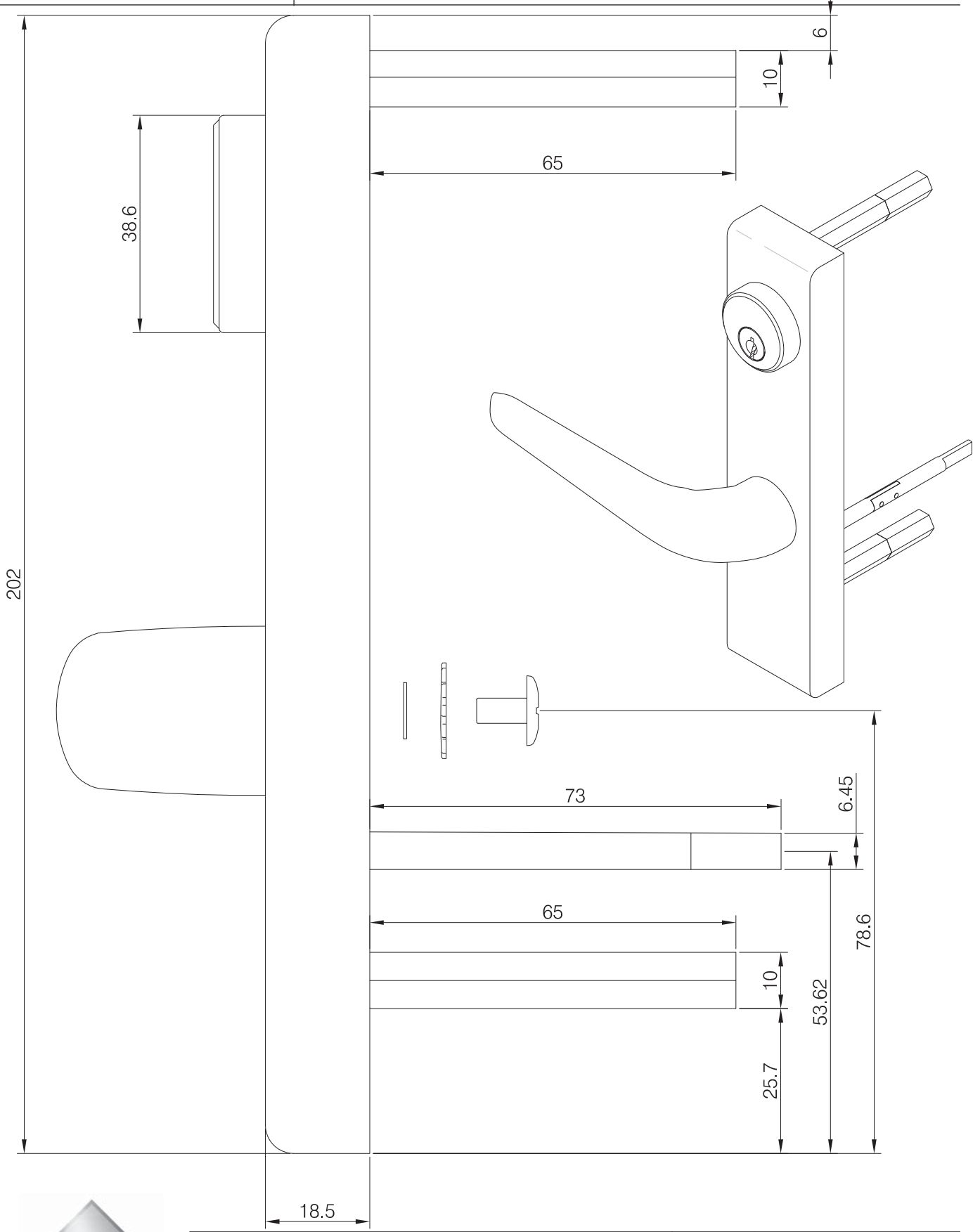

**The Parkside Group Ltd**  
 The Willow Centre  
 17 Willow Lane, Mitcham, Surrey, CR4 4NX  
 Tel: 020-8685 9685 Fax: 020-8646 5096  
 Email: axim@parksidegroup.co.uk  
 Web Site: www.axim.co.uk

SCALE	NTS @A4
DATE	JULY 2017
For scaled technical or CAD drawings, please contact AXIM.	

**Introduction**

Axim Emergency Exit Hardware is guaranteed for a period of 30 months from the date of manufacture against defect in material and workmanship. The guarantee is void if the product has been incorrectly installed or damaged in use. The following notes provide information relating to correct specification of hardware and outlines recommended maintenance procedures which should ensure the hardware will operate trouble free for many years.

There are many types of emergency exit devices and this document will cover 3 of those types.

- Emergency exit push handle
- Concealed panic bolt push bar
- Panic Latch push bar.

Some of these types are handed and Fig. 1 explains how to determine the hand. This is most important when quoting hardware and helps eliminate costly mistakes.

Door handing fig.1

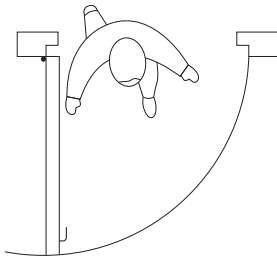

Left hand door  
LHRB

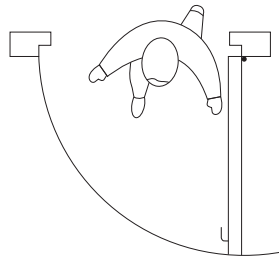

Right hand door  
RHRB

**Emergency exit push handle / push bar with concealed locking rods**

The emergency exit push handle comprises a handed push paddle which operates concealed locking rods. This type is designed for use with hollow doors i.e. aluminium, steel or PVCu. It is not suitable for timber doors. The push bar type uses the same internal mechanism which is activated by the full width crash bar. The mechanism may be connected to either housing and therefore the unit is non-handed.

It is important to realise the internal handles are designed to be pushed in an emergency to release the door and although the handles are used to pull the door closed to reset the hardware. They are not intended to be used in high traffic areas where the handles are used to pull doors closed on regular intervals.

If installed correctly the hardware requires little maintenance, however, the following instructions will extend the life of the product if carried out on a regular basis.

**Six monthly maintenance**

Check that the emergency exit hardware operates and the door can be opened in the correct manner. Ensure the door operates smoothly and carry out routine maintenance as per door manufacturers instructions.

With the door open depress the bar or paddle handle and release, the bolts should remain retracted whilst the door is in this open position.

The top bolt should clear the underside of the transom by no less than 3mm. In most cases this will be level with the top of the door. With the door still open activate the trip mechanism, positioned at the top of the door on the closing face, the bolts should throw immediately.

It is important that the catch operates correctly, especially in the case of fire doors and alarmed door which will otherwise remain ajar or unlocked. If adjustment is necessary remove the screws securing the nylon guide block in place. Take care not to allow it to drop down inside the stile.

Remove the nylon block and lubricate the steel catch until the spring and catch operate freely.

If the bolt position requires height adjustment, turn the bolt head until the correct projection is achieved. Ensure the bolt retracts completely when depressing the panic bar or handle.

Refit the guide block by reverse procedure.

Adjustment to the bottom bolt can be carried out in the same way.

Check the housing to both door stiles for the push bar type or the single housing for the push paddle type. The housings can be removed by slackening the 3 No. 15/32" x 1/4" set screws with a 3mm Allen key. The active housing can be removed from the door by sliding out the connecting pin from the actuator pin. This will present the 2 No. shoulder bolts which should be secured firmly. If an outside rim cylinder has also been fitted 2 No. screws should also be visible, check these screws are secure taking care not to over tighten. The operating mechanism can be lubricated with a spray grease through the actuator pin slot and the housing reinstated by reverse procedure.

If faults can not be rectified using the information above contact the supplier for further advice.



**The Parkside Group Ltd**

The Willow Centre  
17 Willow Lane, Mitcham, Surrey, CR4 4NX  
Tel: 020-8685 9685 Fax: 020-8646 5096  
Email: axim@parksidegroup.co.uk  
Web Site: www.axim.co.uk

SCALE	NTS @A4
DATE	MARCH 2014
For scaled technical or CAD drawings, please contact AXIM.	





TITLE	<b>EXIT DEVICE PR-7000 SERIES</b>	SHEET No. <b>4:43</b>
SUB TITLE	<b>TECHNICAL SUPPORT</b>	

### **Panic exit latch**

The emergency exit panic latch utilises a push bar which operates a latch. This type is designed for use with hollow doors i.e. aluminium, steel or PVCu. For use with timber doors fixing plates must be fabricated to accept the shoulder bolts supplied. The latch type mechanisms are handed and cannot be altered in the field.

It is important to realise the internal handles are designed to be pushed in an emergency to release the door and although the handles are used to pull the door closed to reset the hardware. They are not intended to be used in high traffic areas where the handles are used to pull door closed on regular intervals.

If installed correctly the hardware requires little maintenance, however, the following instructions will extend the life of the product is carried out on a regular basis.

### **Six monthly maintenance**

Check that the emergency exit hardware operates and the door can be opened in the correct manner. Ensure the door operates correctly, without binding and carry out routine maintenance as per door manufacturers instructions.

With the door open, depress the bar and release, the latch bolt should retract fully and return to its normal position. Each housing can be removed by slackening the 3 No. 15/32" x 1/4" set screws with a 3mm Allen Key. With the crash bar still attached lift the unit away from the door.

With a light spray grease lubricate the 2 No. return springs and internal components. Do NOT remove the 2 No. pozi head screws at the top of the unit.

Check the 2 No. shoulder bolts to each door stile and secure if necessary. If the door is furnished with an outside rim cylinder, check to ensure correct operation and lubricate with a light graphite lubricant. Do not use oil.

Reinstate the housings in reverse procedure and tighten the set screws. Lightly oil the pivots through the sides of each housing and wipe clean. Check the bar is fitted tightly between the housings. Apply a light lubricant to the roller on the lock keep and adjust the keep position if necessary. Check fixings are all tight.

If faults can not be rectified using the information above contact the supplier for further advice.



## **The Parkside Group Ltd**

The Willow Centre  
17 Willow Lane, Mitcham, Surrey, CR4 4NX  
Tel: 020-8685 9685 Fax: 020-8646 5096  
Email: [axim@parksidegroup.co.uk](mailto:axim@parksidegroup.co.uk)  
Web Site: [www.axim.co.uk](http://www.axim.co.uk)

SCALE	NTS @A4
DATE	MARCH 2014
For scaled technical or CAD drawings, please contact AXIM.	



**MAXIMUM SECURITY**

hardened steel bolt, zinc plated with anti-rattle sleeve.  
 18mm bolt stroke.  
 7mm zinc plated steel rod with fully threaded length, easily adapted for non-standard door installations.  
 Lengths available 305mm (12 inch).  
 "Centre Punch" tip to mark centre of keep.

Die cast zinc alloy body mechanism.  
 Fixing holes tapped M5.  
 Fixings included.  
 Deep finger recess and large lever for ease of operation.  
 Corners 2.5mm radius for easy matching of cut out.

**FINISHES AVAILABLE**

Mill finish - for customers own finish.  
 Silver - Satin chrome.  
 Bronze - Powder coat.  
 White - Powder coat.  
 Black - Powder coat.

PRODUCT CODES			
LENGTH	FINISH	FLAT	RADIUS
305mm (12 inch)	MILL	62.00F12	62.00R12
	SILVER	62.01F12	62.01R12
	BRONZE	62.02F12	62.02R12
	WHITE	62.01F12	62.01R12
	BLACK	62.02F12	62.02R12
SHIPPING WEIGHT 2.52Kg. PER 10			

Bolt guide by door manufacturer.

**Floor Socket Keep**

Sprung loaded, dust resistant, satin chrome finish.

PRODUCT CODE	SOCKET KEEP
	62.035
SHIPPING WEIGHT 2.52Kg. PER 10	

**GUARANTEE**

AXIM FLUSH BOLTS ARE GUARANTEED FOR 30 MONTHS FROM THE DATE OF MANUFACTURE AGAINST DEFECT IN MATERIAL AND WORKMANSHIP. THIS GUARANTEE IS VOID IF THE PRODUCT HAS BEEN INCORRECTLY INSTALLED OR DAMAGED IN USE. CLAIMS FOR DAMAGE INCURRED OR WORK DONE THEREON WILL NOT BE ACCEPTED.

AXIM RESERVE THE RIGHT TO UPDATE ITS PRODUCT SPECIFICATIONS WITHOUT PRIOR NOTICE.



**DOOR PREPARATION**

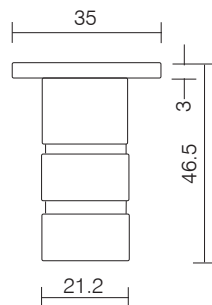
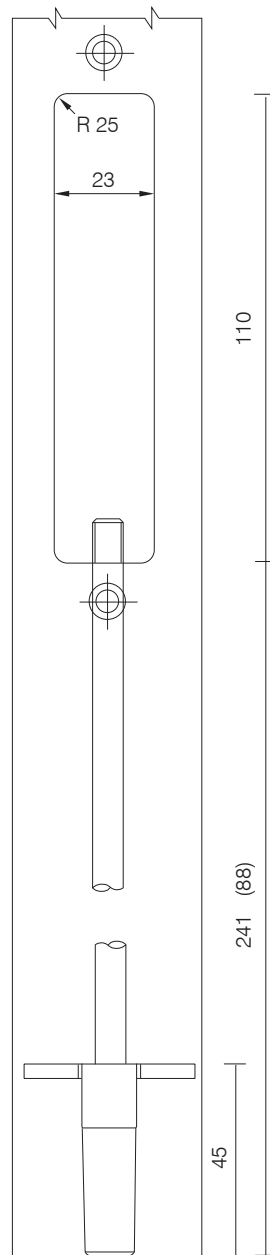

**RADIUSED FACED**

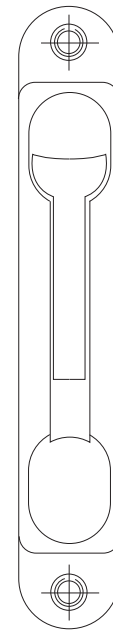

23

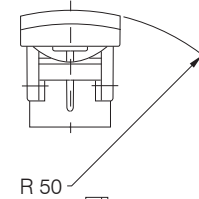

R 50

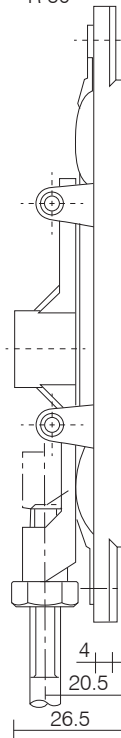

**FLAT FACED**

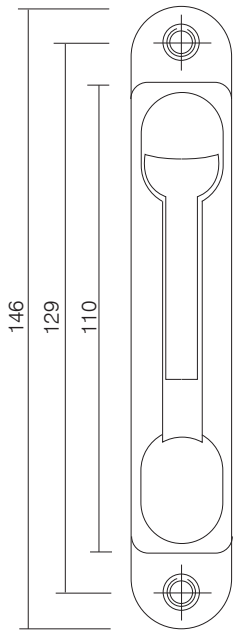

23

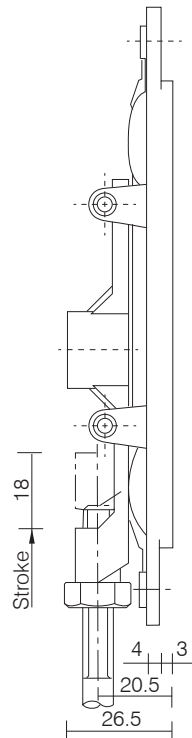
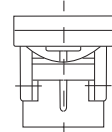

**The Parkside Group Ltd**

The Willow Centre  
 17 Willow Lane, Mitcham, Surrey, CR4 4NX  
 Tel: 020-8685 9685 Fax: 020-8646 5096  
 Email: axim@parksidegroup.co.uk  
 Web Site: www.axim.co.uk

SCALE	NTS @A4
DATE	JULY 2017
For scaled technical or CAD drawings, please contact AXIM.	

Use flush bolt guide FB-62-040  
to support top of flush bolt

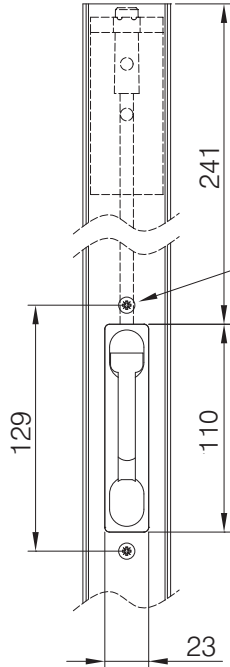

Flush bolt (FB6200) used at  
top and bottom of stile for  
locking purposes

Drill & csk. for M5 typ.

Rout out cutout using  
5mm cutter to achieve  
2.5mm rads in corners

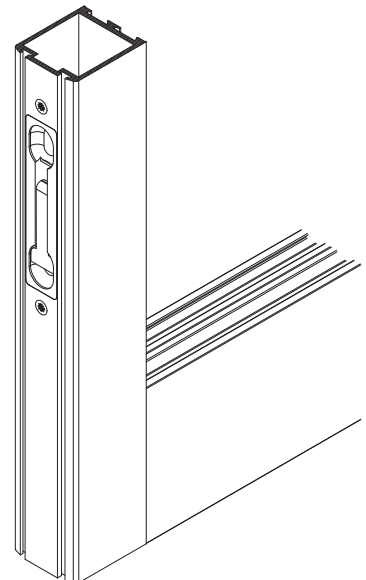
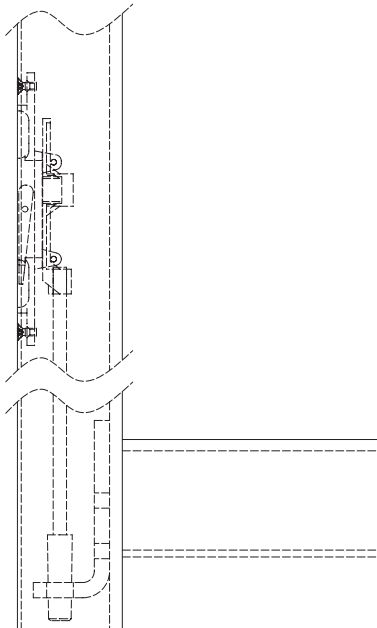
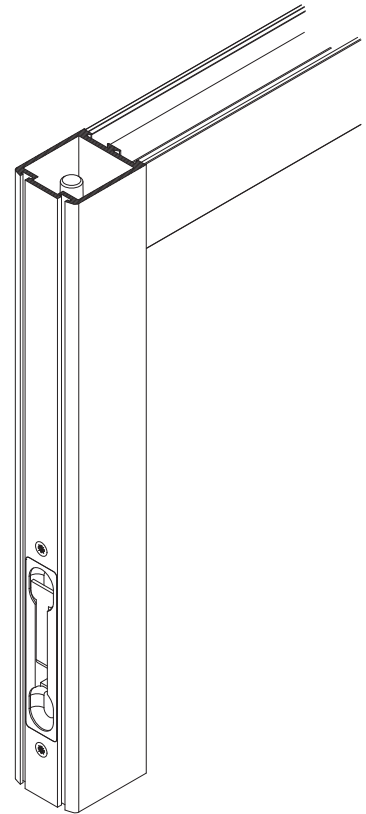

**MAXIMUM SECURITY**

hardened steel bolt, zinc plated with anti-rattle sleeve.  
18mm bolt stroke.  
7mm zinc plated steel rod with fully threaded length, easily adapted for non-standard door installations.  
Lengths available 700mm.  
"Centre Punch" tip to mark centre of keep.

Die cast zinc alloy body mechanism.  
Fixing holes tapped M5.  
Fixings included.  
Deep finger recess and large lever for ease of operation.

**FINISHES AVAILABLE**

Mill finish - for customers own finish.  
Silver - Satin chrome.

PRODUCT CODES		
LENGTH	FINISH	FLAT
700mm	SILVER	FB-6301-F28*
SHIPPING WEIGHT 3.86Kg. PER 10		

\*SPECIAL ORDER ONLY. NON-STOCK ITEM

Bolt guide by door manufacturer.

**Floor Socket Keep**

Sprung loaded, dust resistant, satin chrome finish.

PRODUCT CODE	SOCKET KEEP
	62.035
SHIPPING WEIGHT 2.52Kg. PER 10	

**GUARANTEE**

AXIM FLUSH BOLTS ARE GUARANTEED FOR 30 MONTHS FROM THE DATE OF MANUFACTURE AGAINST DEFECT IN MATERIAL AND WORKMANSHIP. THIS GUARANTEE IS VOID IF THE PRODUCT HAS BEEN INCORRECTLY INSTALLED OR DAMAGED IN USE. CLAIMS FOR DAMAGE INCURRED OR WORK DONE THEREON WILL NOT BE ACCEPTED.

AXIM RESERVE THE RIGHT TO UPDATE ITS PRODUCT SPECIFICATIONS WITHOUT PRIOR NOTICE.

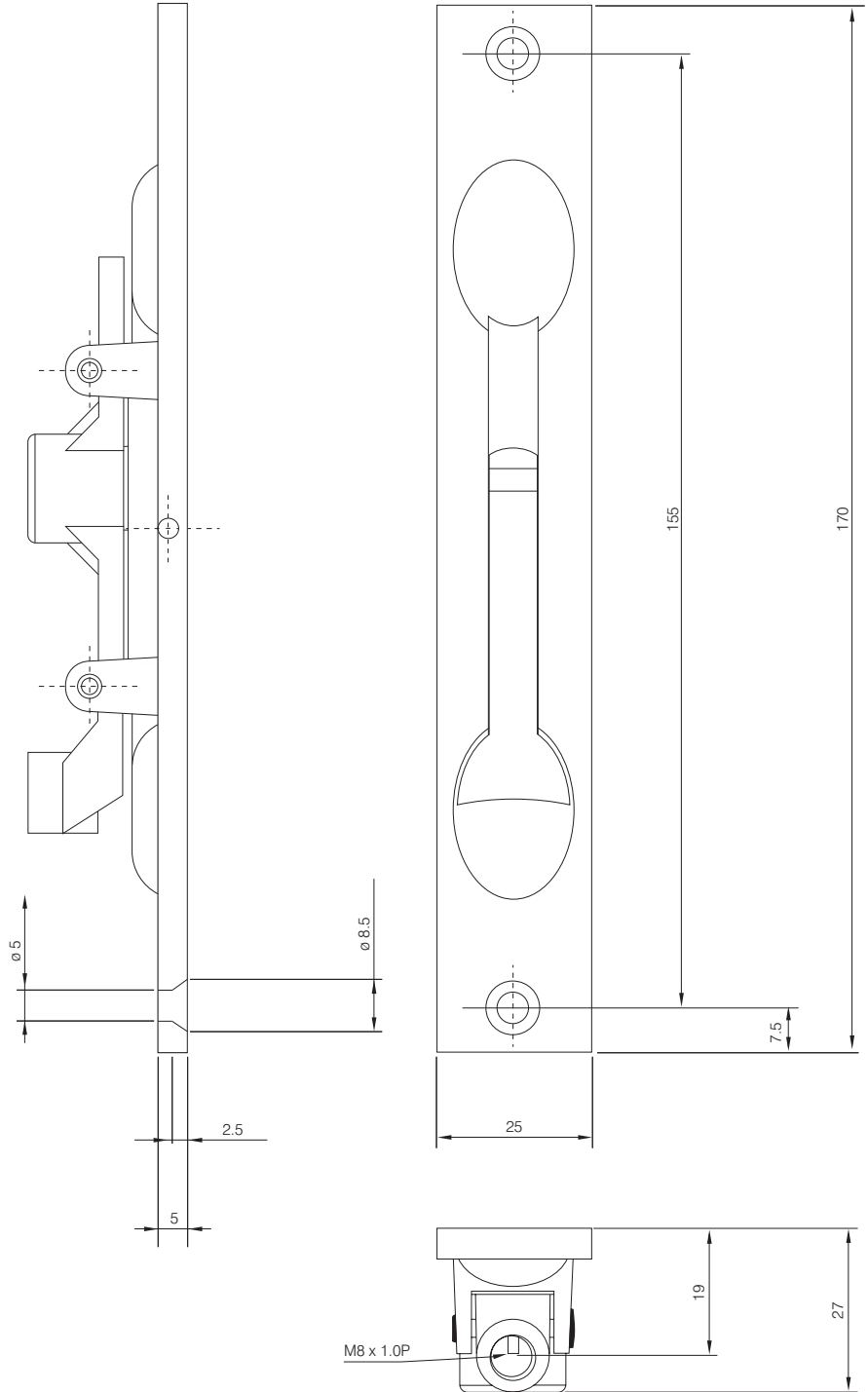

**The Parkside Group Ltd**

The Willow Centre  
17 Willow Lane, Mitcham, Surrey, CR4 4NX  
Tel: 020-8685 9685 Fax: 020-8646 5096  
Email: axim@parksidegroup.co.uk  
Web Site: www.axim.co.uk

SCALE	NTS @A4
DATE	JULY 2017

For scaled technical or CAD drawings, please contact AXIM.

**MAXIMUM SECURITY**

hardened steel bolt, zinc plated with anti-rattle sleeve.  
18mm bolt stroke.  
7mm zinc plated steel rod with 30mm thread length, easily adapted for non-standard door installations.  
Lengths available 110mm & 230mm.  
"Centre Punch" tip to mark centre of keep.

Die cast zinc alloy body mechanism.  
Fixing holes tapped M5.  
Fixings included.  
Deep finger recess and large lever for ease of operation.

**FINISHES AVAILABLE**

Mill finish - for customers own finish.  
Silver - Satin chrome.

PRODUCT CODES		
LENGTH	FINISH	FLAT
110mm	SILVER	FB-6401-F045*
SHIPPING WEIGHT 1.72Kg. PER 10		

PRODUCT CODES		
LENGTH	FINISH	FLAT
230mm	SILVER	FB-6401-F095*
SHIPPING WEIGHT 1.59Kg. PER 10		

\*SPECIAL ORDER ONLY. NON-STOCK ITEM

Bolt guide by door manufacturer.

**Floor Socket Keep**

Sprung loaded, dust resistant, satin chrome finish.

PRODUCT CODE	SOCKET KEEP
	62.035
SHIPPING WEIGHT 2.52Kg. PER 10	

**GUARANTEE**

AXIM FLUSH BOLTS ARE GUARANTEED FOR 30 MONTHS FROM THE DATE OF MANUFACTURE AGAINST DEFECT IN MATERIAL AND WORKMANSHIP. THIS GUARANTEE IS VOID IF THE PRODUCT HAS BEEN INCORRECTLY INSTALLED OR DAMAGED IN USE. CLAIMS FOR DAMAGE INCURRED OR WORK DONE THEREON WILL NOT BE ACCEPTED.

AXIM RESERVE THE RIGHT TO UPDATE ITS PRODUCT SPECIFICATIONS WITHOUT PRIOR NOTICE.

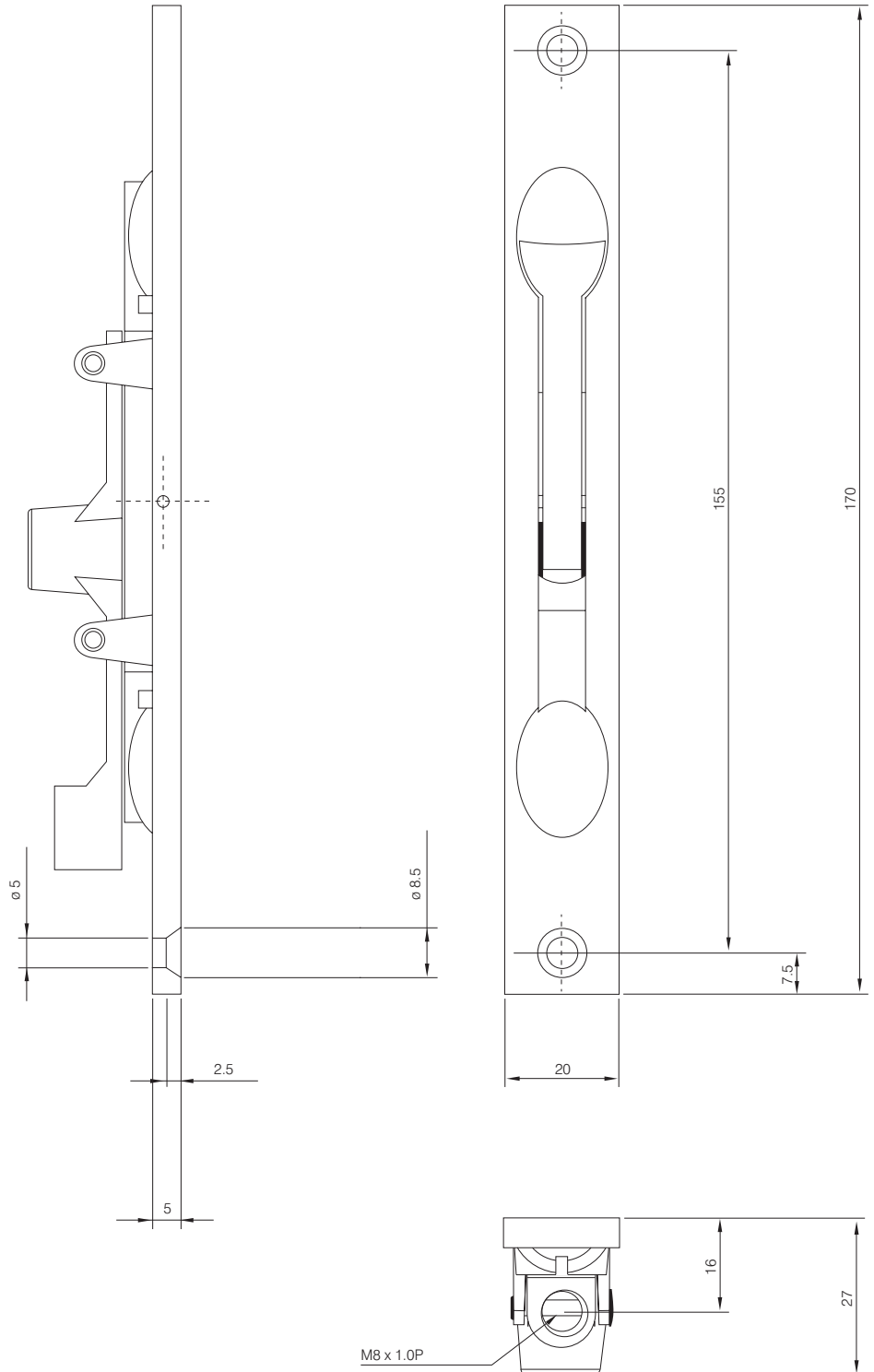

The Parkside Group Ltd

The Willow Centre  
17 Willow Lane, Mitcham, Surrey, CR4 4NX  
Tel: 020-8685 9685 Fax: 020-8646 5096  
Email: axim@parksidegroup.co.uk  
Web Site: www.axim.co.uk

SCALE	NTS @A4
DATE	JULY 2017

For scaled technical or CAD drawings, please contact AXIM.

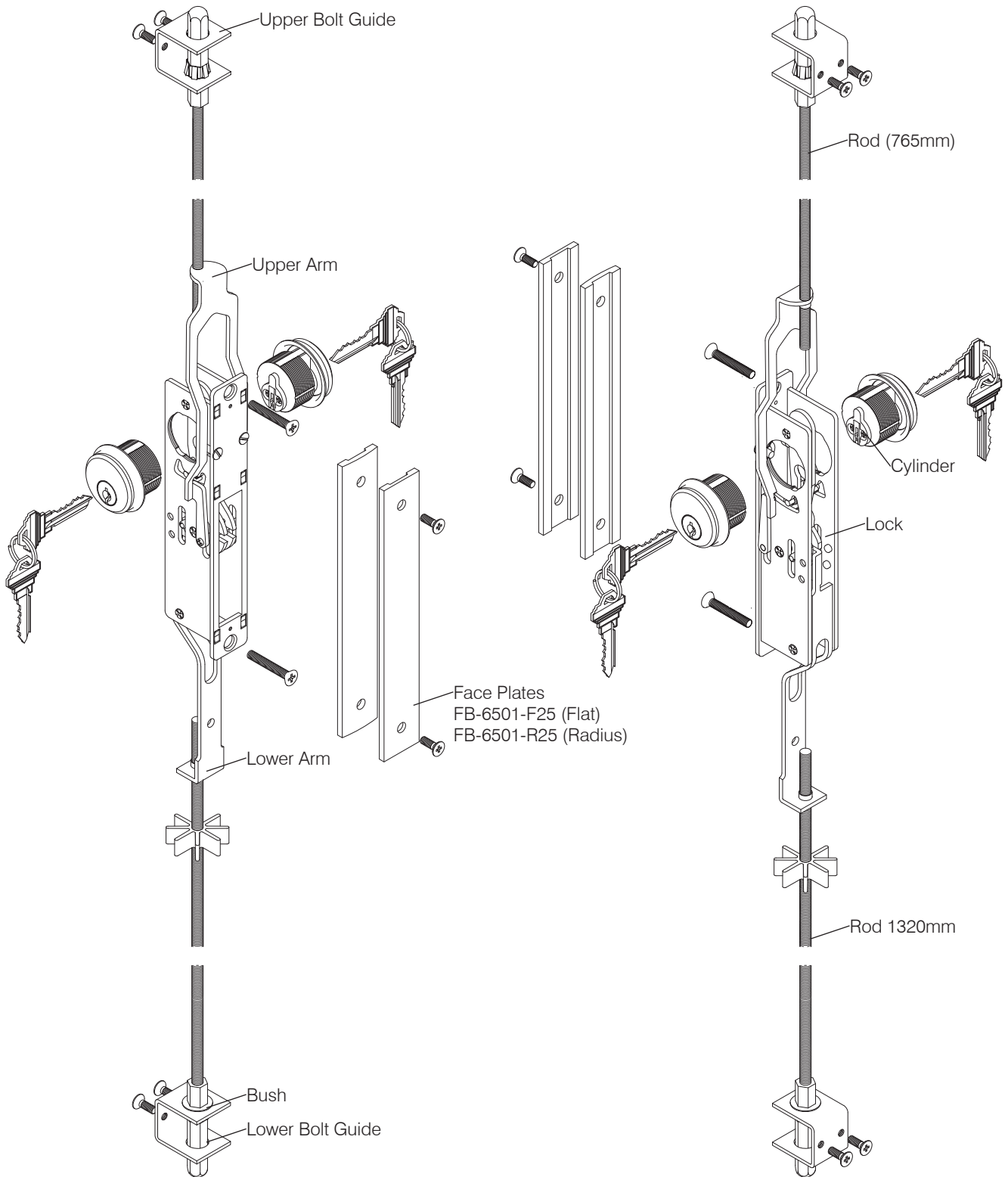

The Parkside Group Ltd

The Willow Centre  
17 Willow Lane, Mitcham, Surrey, CR4 4NX  
Tel: 020-8685 9685 Fax: 020-8646 5096  
Email: axim@parksidegroup.co.uk  
Web Site: www.axim.co.uk

SCALE NTS @A4

DATE JULY 2017

For scaled technical or CAD drawings,  
please contact AXIM.

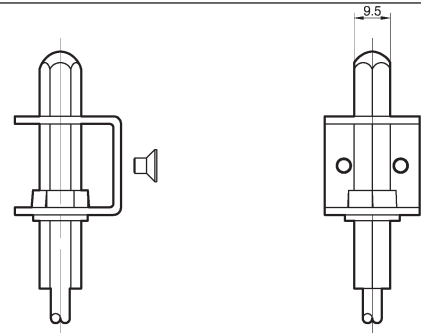
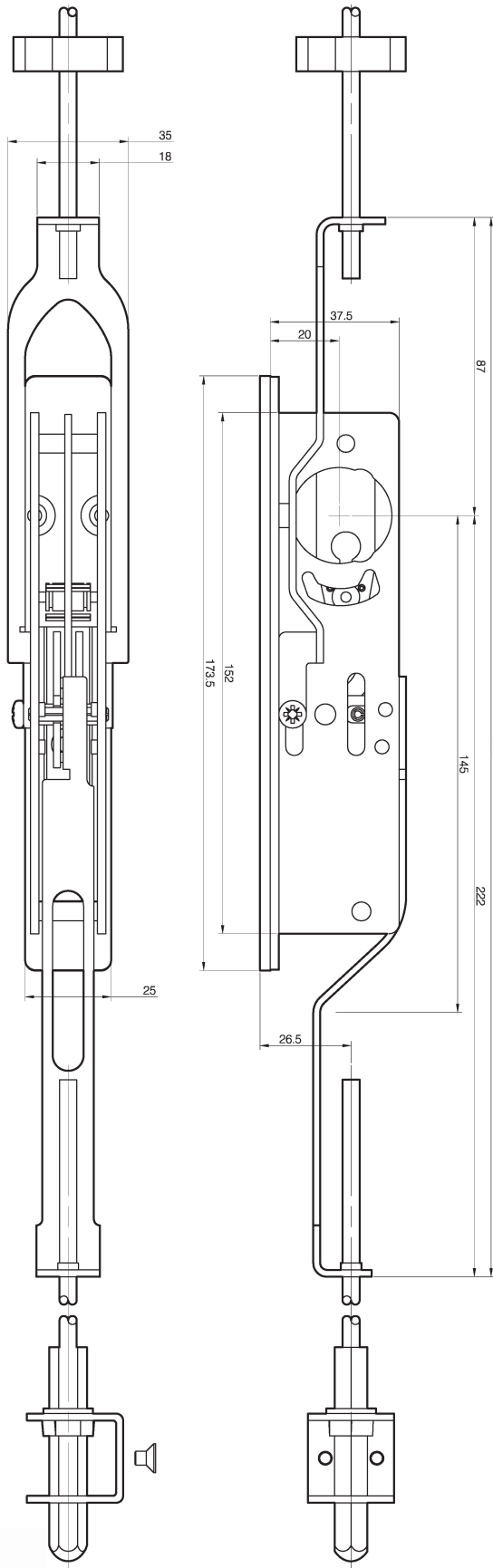

Top Bolt & Upper Bolt Guide

**Installation Notes:**

Install upper arm over lock side plates  
lower through the stile  
with bolt extended.

Install lower arm  
with bolt retracted.

Rod length cut to suite cylinder height  
to be approx 180mm less than overall cylinder  
height

**Specifications:**

Threshold & Top Bolt:  
Stainless steel Hexagonal 9.5mm flat to flat  
Bolt Throw = 17.5mm

PRODUCT CODES		
FINISH	FLAT	RADIUS
MILL	FB-6501-F25	FB-6501-R25

**Accessories**

**Round Cylinder**

- LK-2100-70** - (Keyed to differ in singles) 46mm DOOR STILE
- LK-2100-71** - (Keyed to differ in pairs) 46mm DOOR STILE
- LK-2100-71-S** - (Keyed alike in Singles) 46mm DOOR STILE
- LK-2100-71-SP** - (Keyed alike in pairs) 46mm DOOR STILE
- LK-2100-73** - Dummy - 46mm DOOR STILE
- LK-2100-75** - Dummy - 67mm DOOR STILE



The Parkside Group Ltd

The Willow Centre  
17 Willow Lane, Mitcham, Surrey, CR4 4NX  
Tel: 020-8685 9685 Fax: 020-8646 5096  
Email: axim@parksidegroup.co.uk  
Web Site: www.axim.co.uk

SCALE	NTS @A4
DATE	JULY 2017

For scaled technical or CAD drawings,  
please contact AXIM.



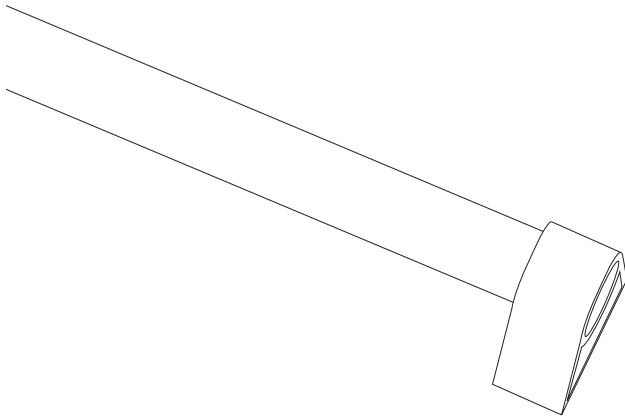

**Series HD80**

Full height tubular handle sets for use with aluminium, steel and solid timber doors comprising:-

2 No. tubes, 2500mm long

4 No. brackets complete with studs, dome nuts and washers

Extruded aluminium tubes have an outside diameter of 40mm and an inside diameter of 30mm giving a wall thickness of 5mm for minimum deflection even in high traffic areas.

Tubes can be cut to suit requirements after door height has been determined.

Extruded aluminium brackets also have a minimum wall thickness of 5mm for rigidity and are capped to conceal the ends of the tubes.

Each bracket is 85mm wide and 39mm high with a projection of 90mm from the door leaf.

Brackets are drilled to accept the 10mm threaded stud for fixing and drilled and tapped for the M5 grub screws that hold the tube firmly in position eliminating rattle.

**Finishes**

Tube handle sets are available ex-stock in the following finishes:-

Satin silver aluminium anodised

Dark bronze anodised

White polyester powder coated

Mill finish for customers own treatment

Special colours are obtainable to special order. Please contact Sales Office for information.

AXIM reserve the right to update its product specification without prior notice.

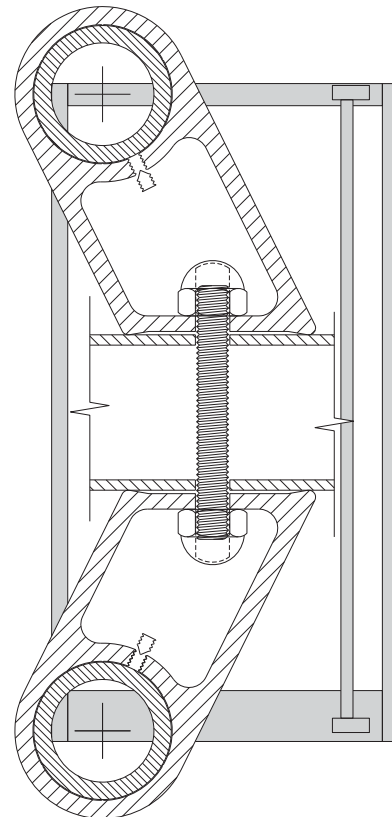
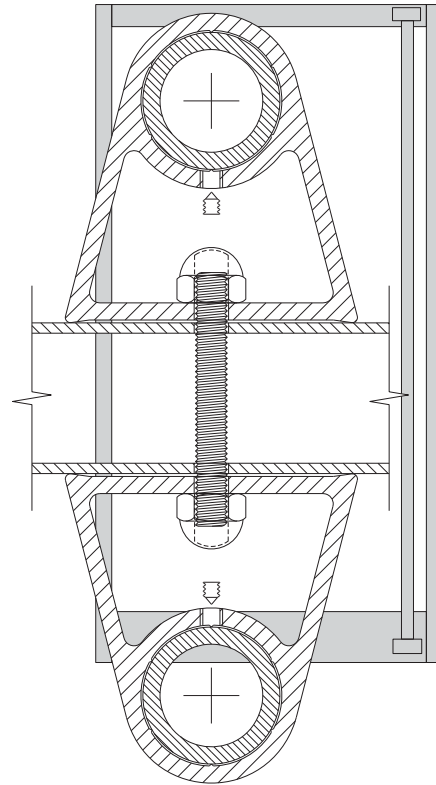

**The Parkside Group Ltd**

The Willow Centre  
17 Willow Lane, Mitcham, Surrey, CR4 4NX  
Tel: 020-8685 9685 Fax: 020-8646 5096  
Email: axim@parksidegroup.co.uk  
Web Site: www.axim.co.uk

SCALE NTS @A4

DATE MARCH 2014

For scaled technical or CAD drawings, please contact AXIM.

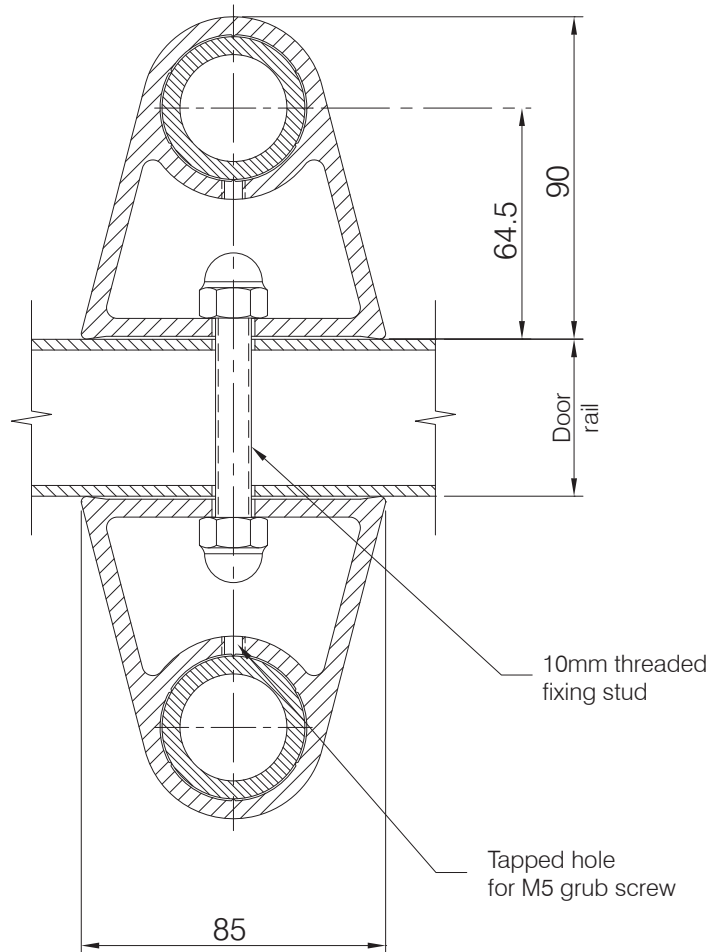

**The Parkside Group Ltd**

The Willow Centre  
17 Willow Lane, Mitcham, Surrey, CR4 4NX  
Tel: 020-8685 9685 Fax: 020-8646 5096  
Email: [axim@parksidegroup.co.uk](mailto:axim@parksidegroup.co.uk)  
Web Site: [www.axim.co.uk](http://www.axim.co.uk)

SCALE NTS @A4

DATE MARCH 2014

For scaled technical or CAD drawings,  
please contact AXIM.

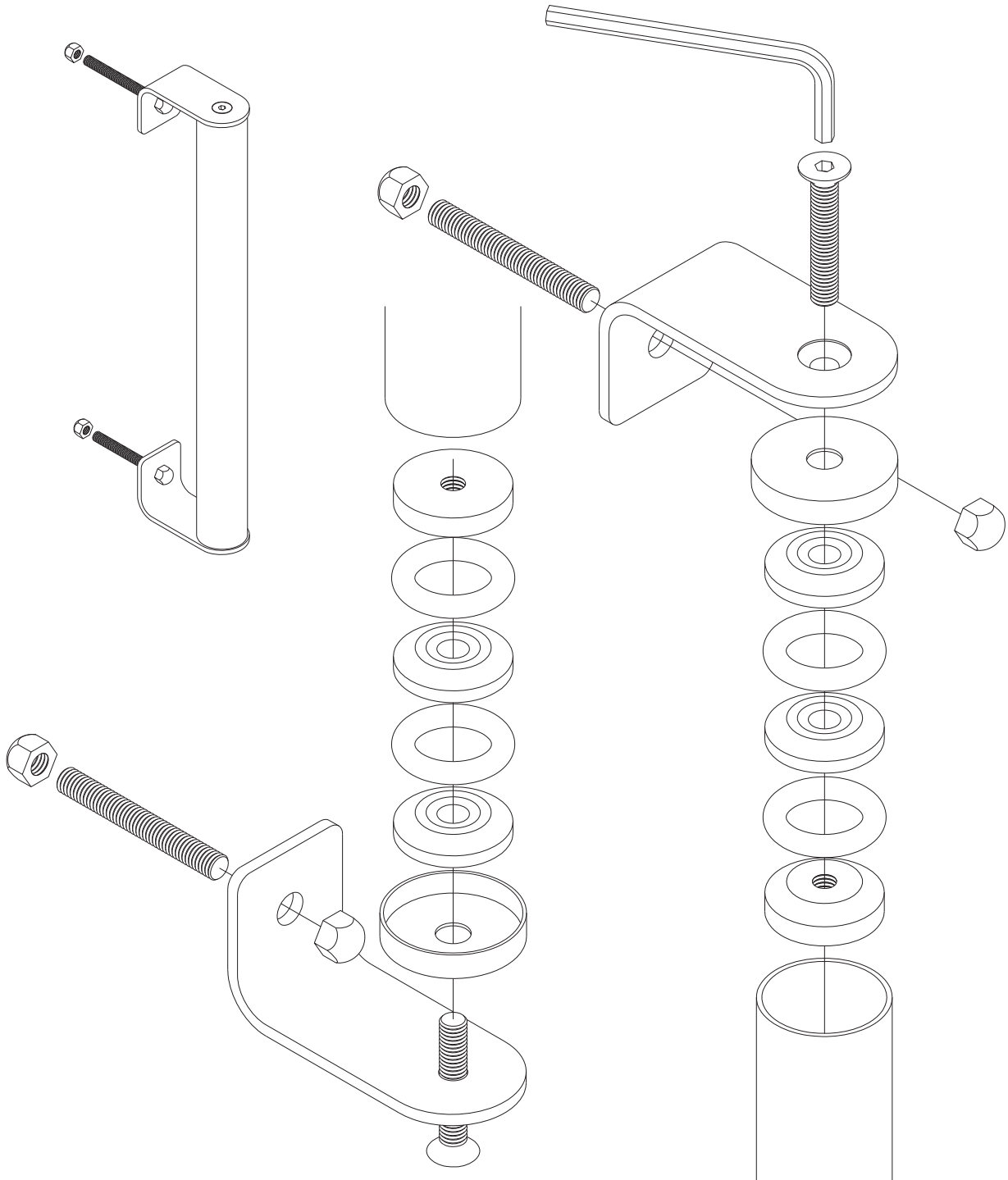

The Parkside Group Ltd

The Willow Centre  
17 Willow Lane, Mitcham, Surrey, CR4 4NX  
Tel: 020-8685 9685 Fax: 020-8646 5096  
Email: axim@parksidegroup.co.uk  
Web Site: www.axim.co.uk

SCALE NTS @A4

DATE MARCH 2014

For scaled technical or CAD drawings,  
please contact AXIM.

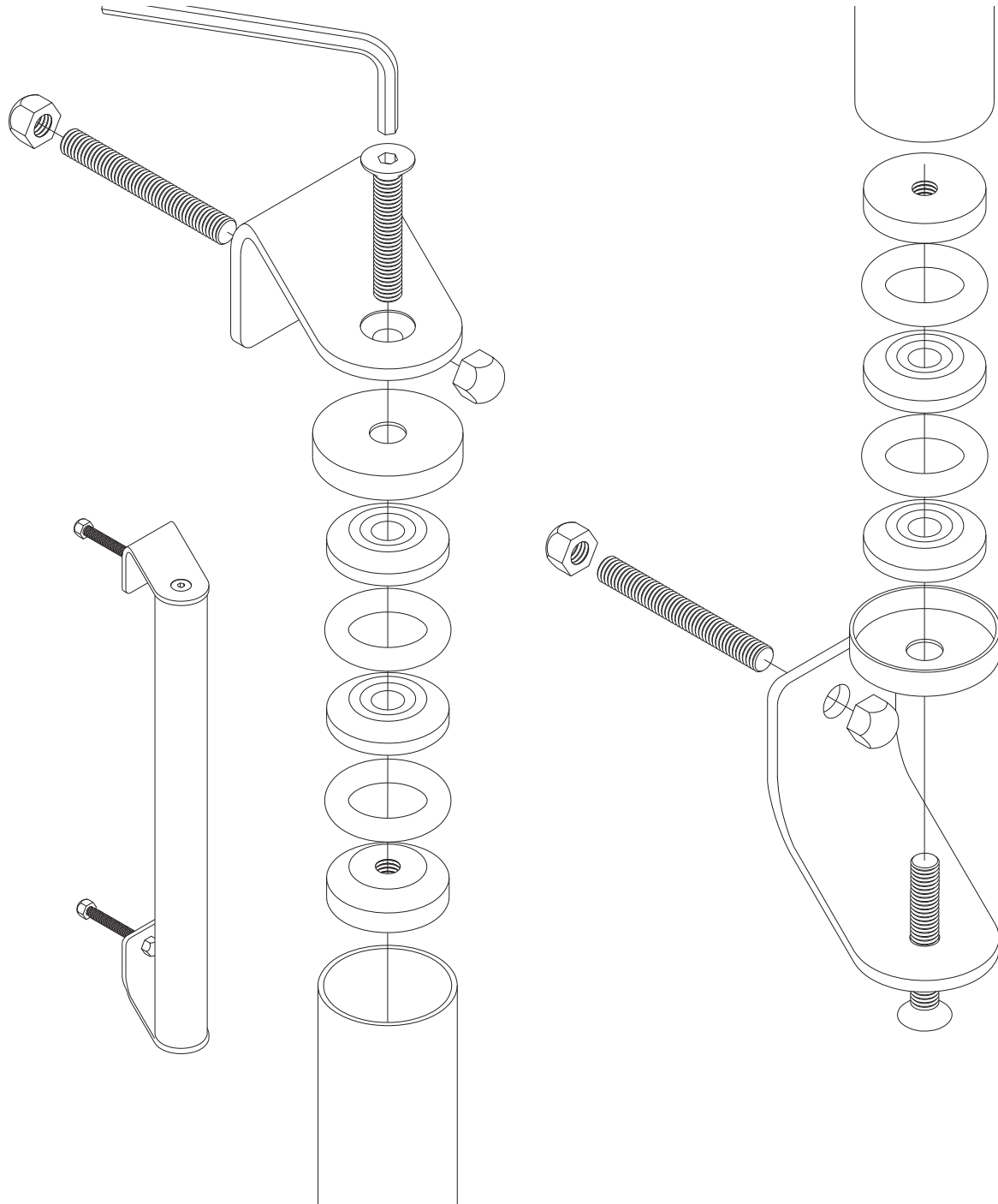

**The Parkside Group Ltd**

The Willow Centre  
17 Willow Lane, Mitcham, Surrey, CR4 4NX  
Tel: 020-8685 9685 Fax: 020-8646 5096  
Email: axim@parksidegroup.co.uk  
Web Site: www.axim.co.uk

SCALE	NTS @A4
DATE	DEC 2014

For scaled technical or CAD drawings,  
please contact AXIM.

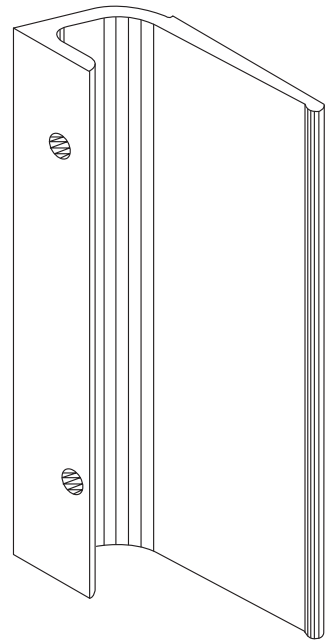
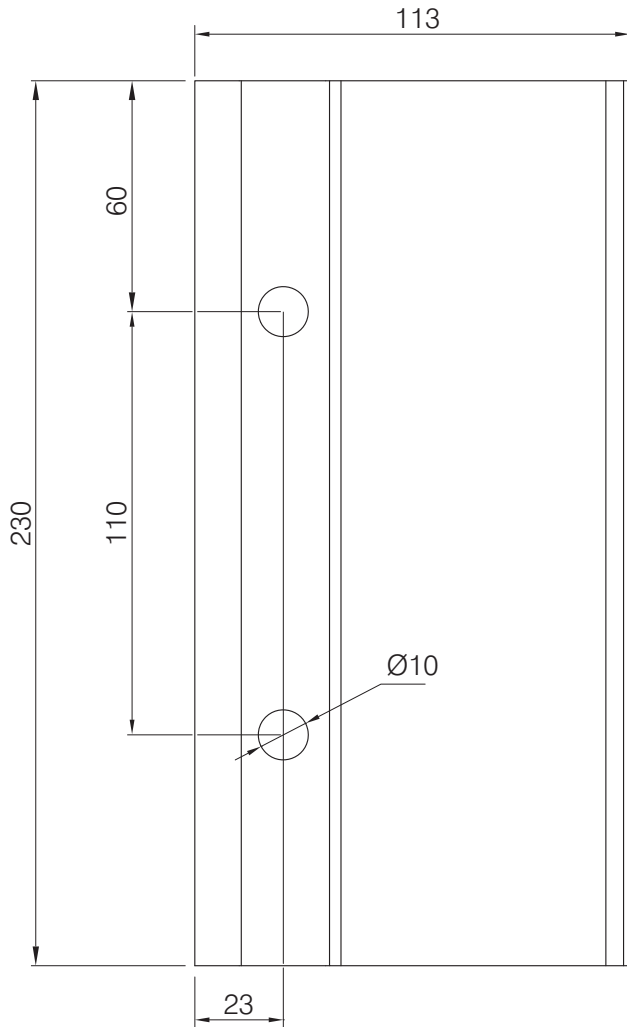
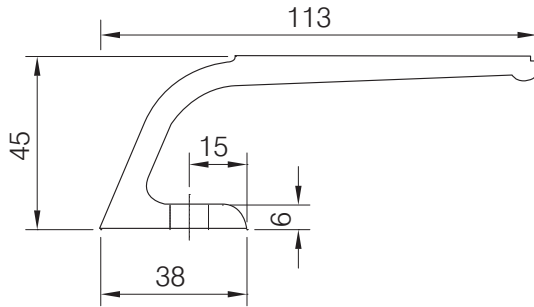

ISO view not to scale

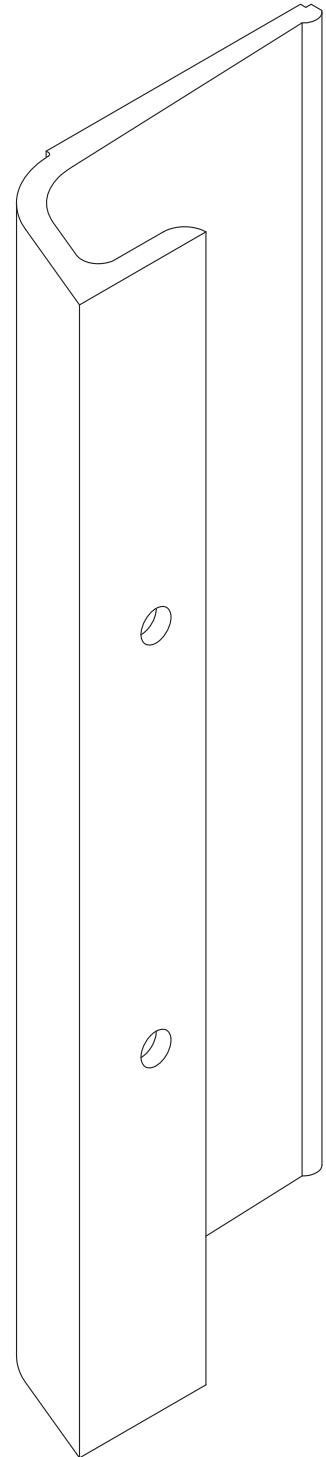
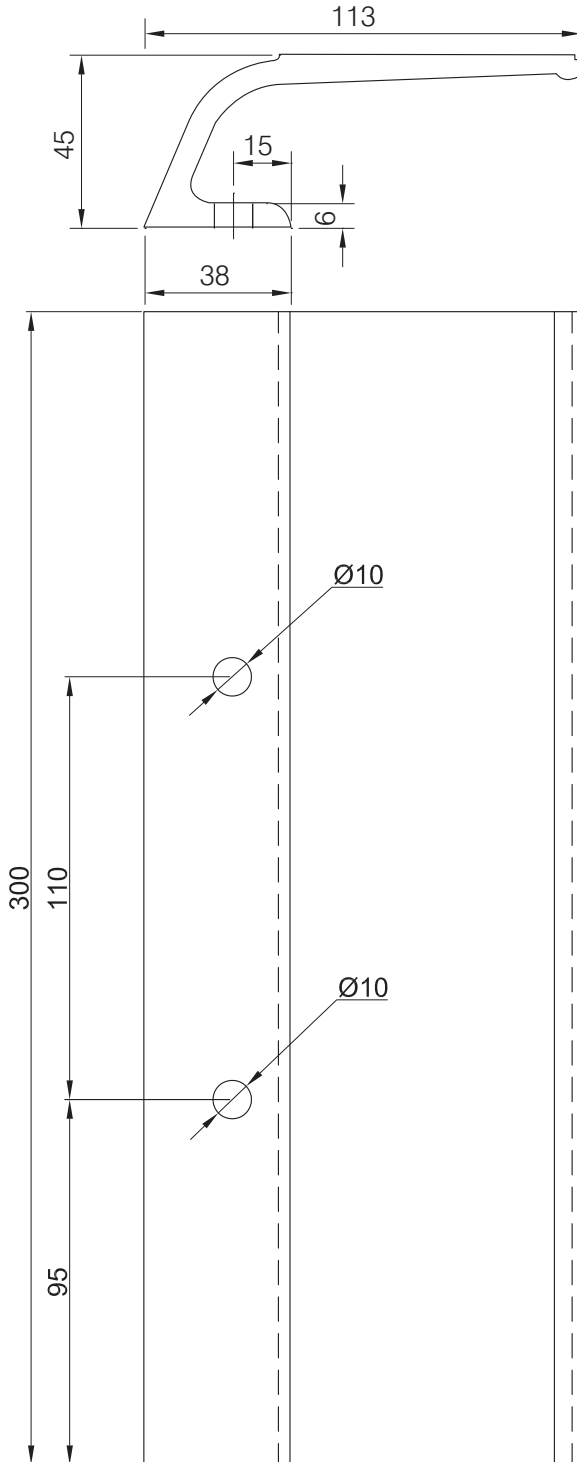

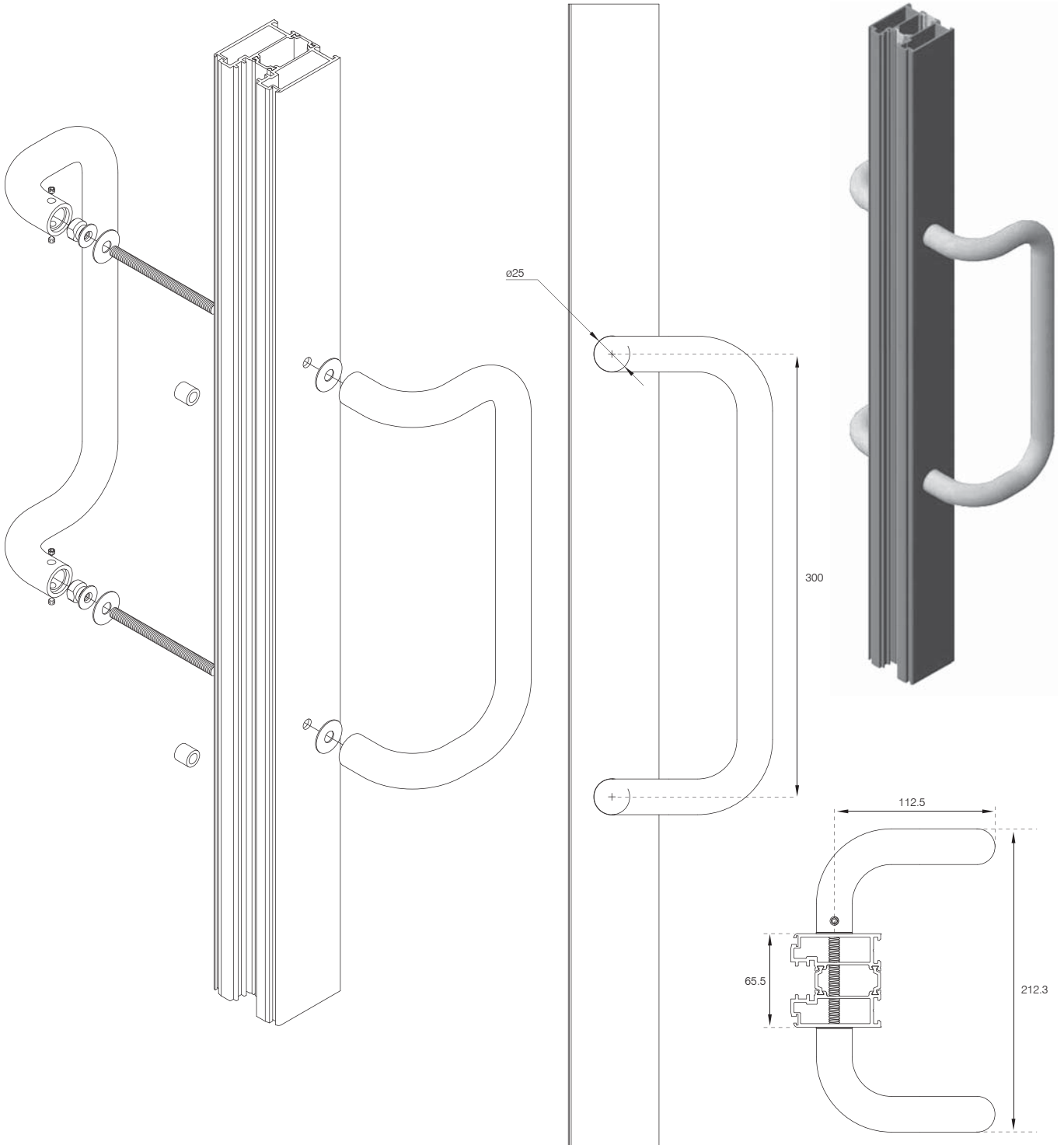

**The Parkside Group Ltd**

The Willow Centre  
17 Willow Lane, Mitcham, Surrey, CR4 4NX  
Tel: 020-8685 9685 Fax: 020-8646 5096  
Email: axim@parksidegroup.co.uk  
Web Site: www.axim.co.uk

SCALE	NTS @A4
DATE	AUGUST 2016

For scaled technical or CAD drawings,  
please contact AXIM.

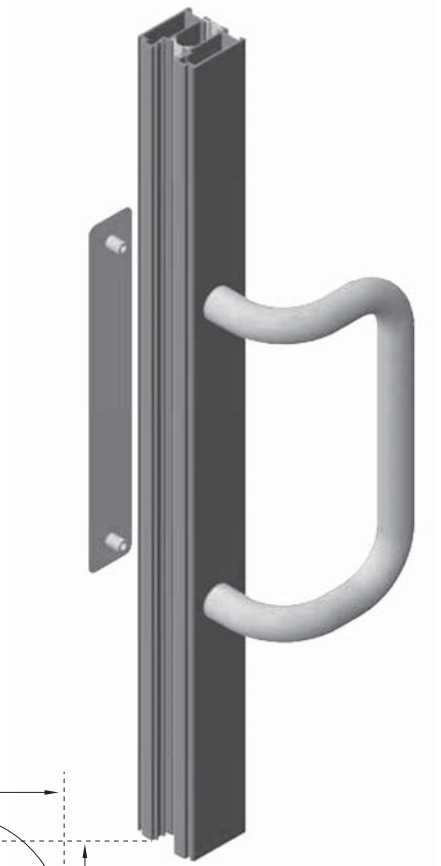
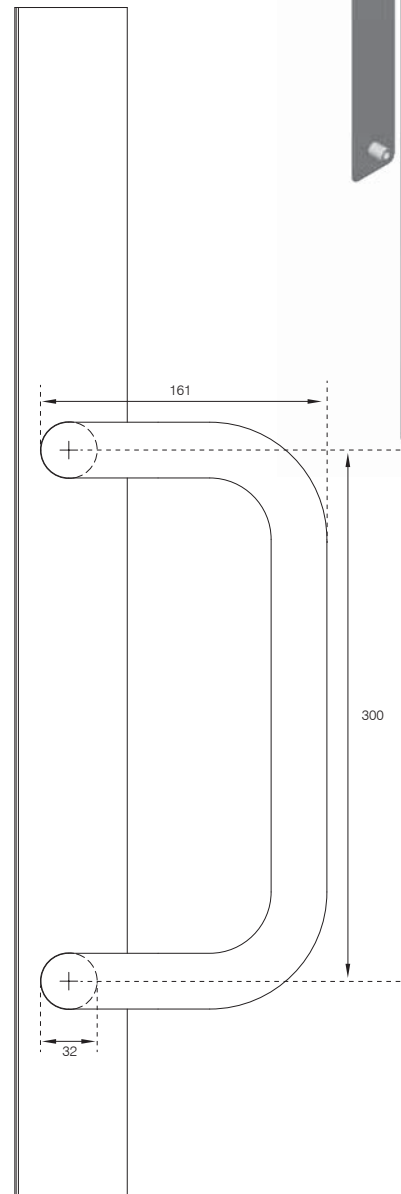
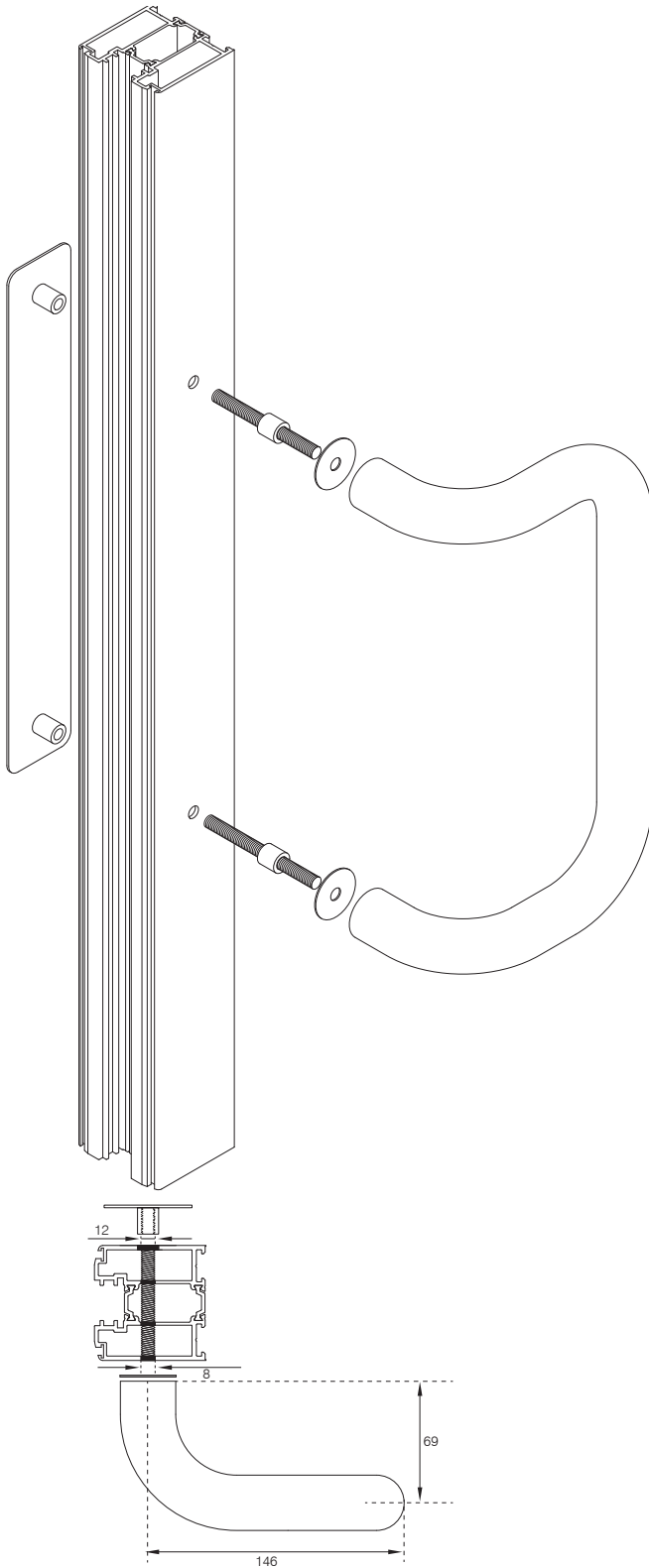

**The Parkside Group Ltd**

The Willow Centre  
17 Willow Lane, Mitcham, Surrey, CR4 4NX  
Tel: 020-8685 9685 Fax: 020-8646 5096  
Email: [axim@parksidegroup.co.uk](mailto:axim@parksidegroup.co.uk)  
Web Site: [www.axim.co.uk](http://www.axim.co.uk)

SCALE NTS @A4

DATE AUGUST 2016

For scaled technical or CAD drawings,  
please contact AXIM.



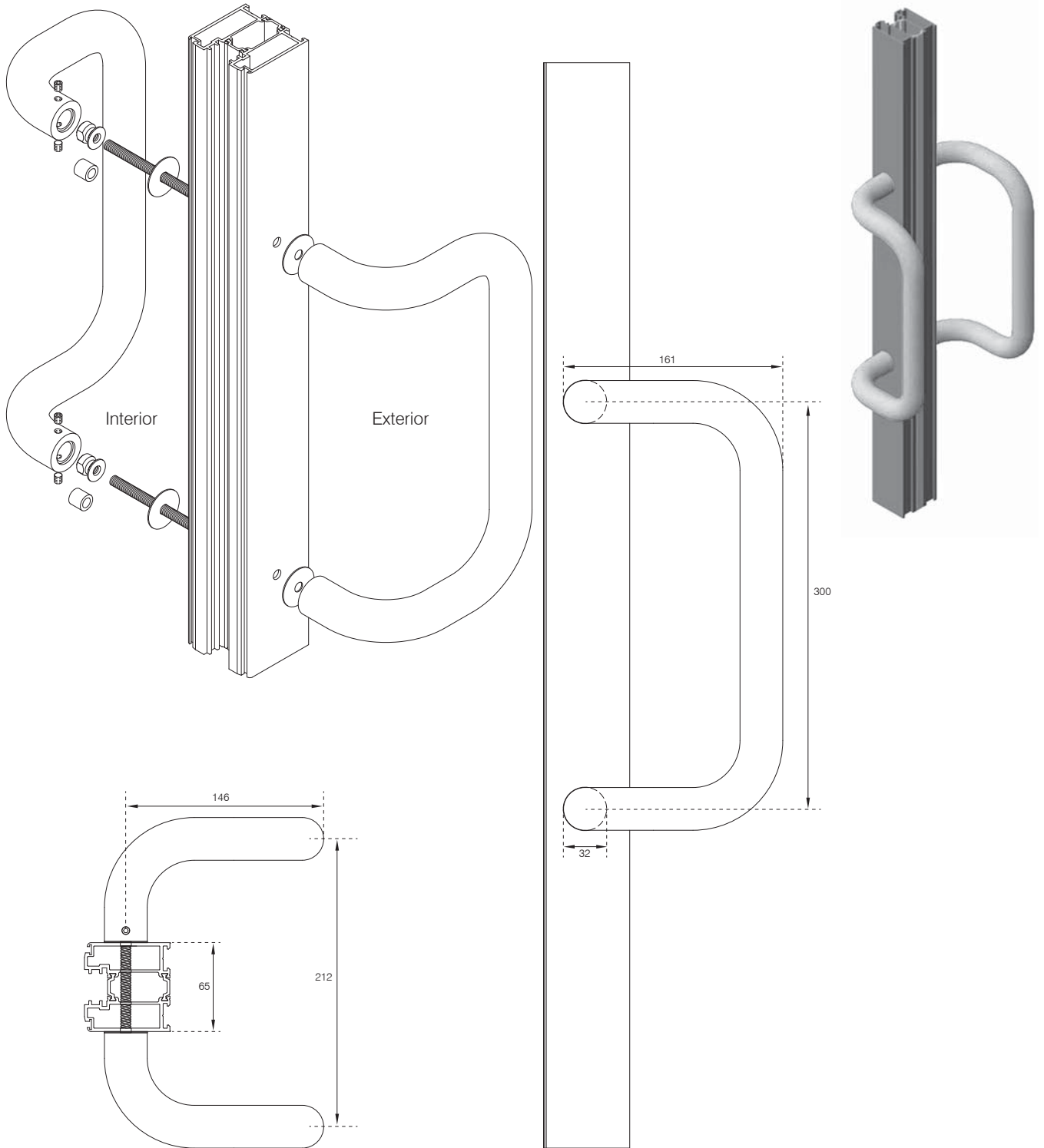

**The Parkside Group Ltd**

The Willow Centre  
17 Willow Lane, Mitcham, Surrey, CR4 4NX  
Tel: 020-8685 9685 Fax: 020-8646 5096  
Email: [axim@parksidegroup.co.uk](mailto:axim@parksidegroup.co.uk)  
Web Site: [www.axim.co.uk](http://www.axim.co.uk)

SCALE	NTS @A4
DATE	AUGUST 2016

For scaled technical or CAD drawings,  
please contact AXIM.

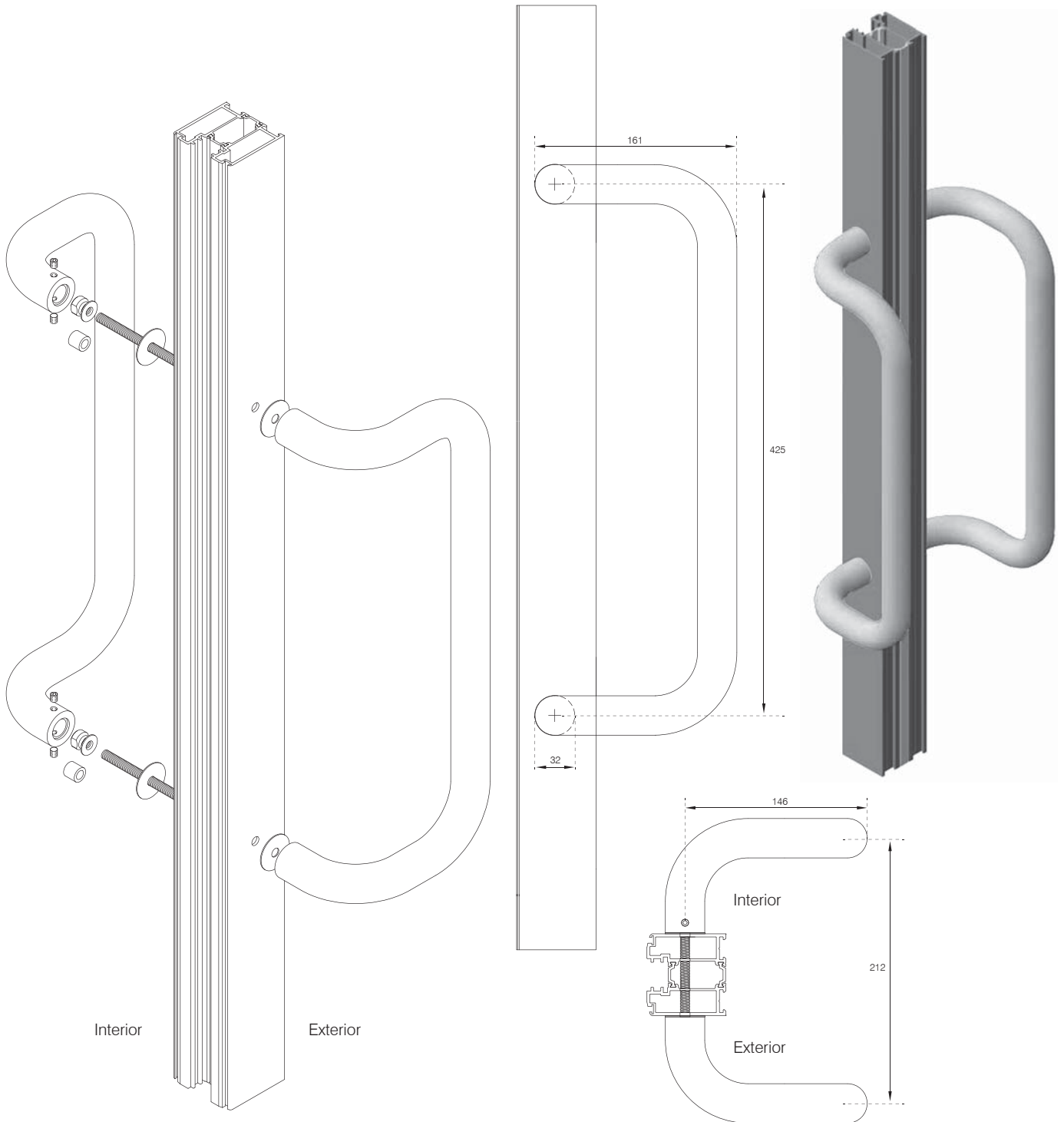

**The Parkside Group Ltd**

The Willow Centre  
 17 Willow Lane, Mitcham, Surrey, CR4 4NX  
 Tel: 020-8685 9685 Fax: 020-8646 5096  
 Email: axim@parksidegroup.co.uk  
 Web Site: www.axim.co.uk

SCALE	NTS @A4
DATE	AUGUST 2016
For scaled technical or CAD drawings, please contact AXIM.	

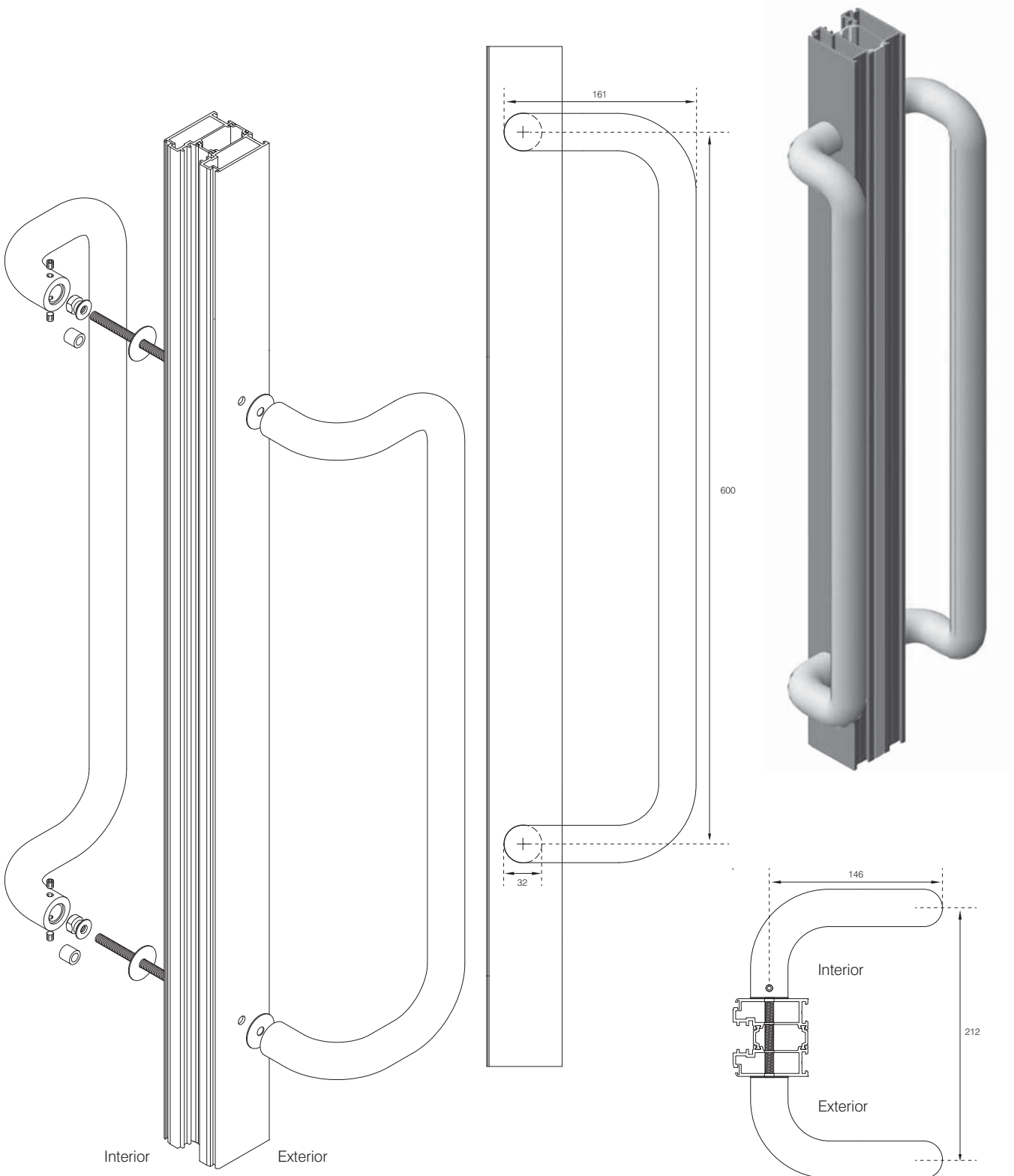

**The Parkside Group Ltd**

The Willow Centre  
17 Willow Lane, Mitcham, Surrey, CR4 4NX  
Tel: 020-8685 9685 Fax: 020-8646 5096  
Email: axim@parksidegroup.co.uk  
Web Site: www.axim.co.uk

SCALE NTS @A4

DATE AUGUST 2016

For scaled technical or CAD drawings,  
please contact AXIM.

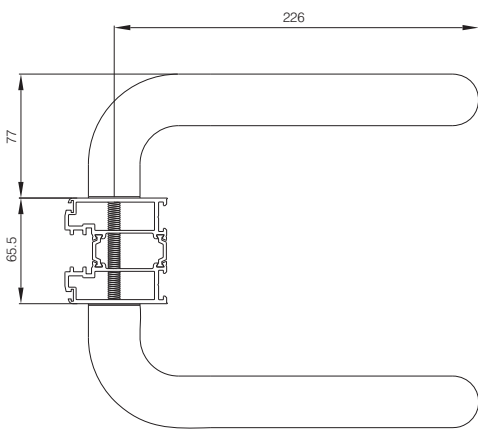
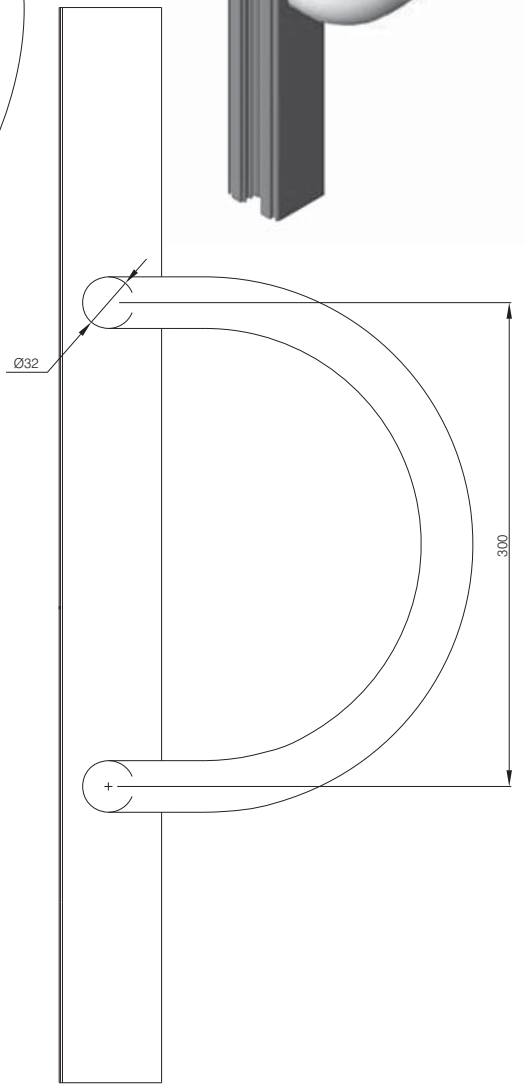
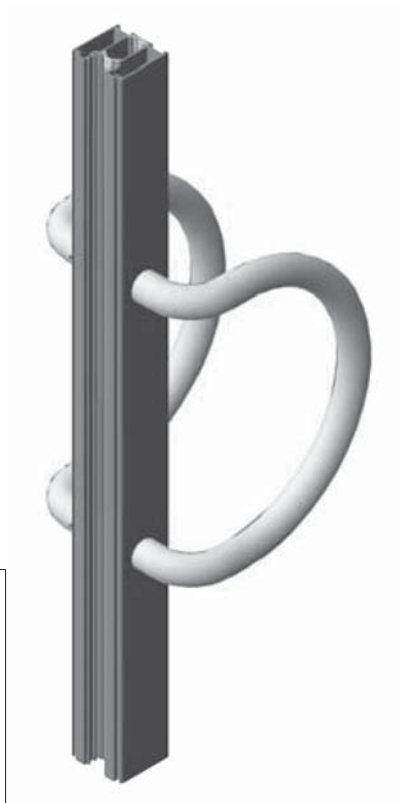
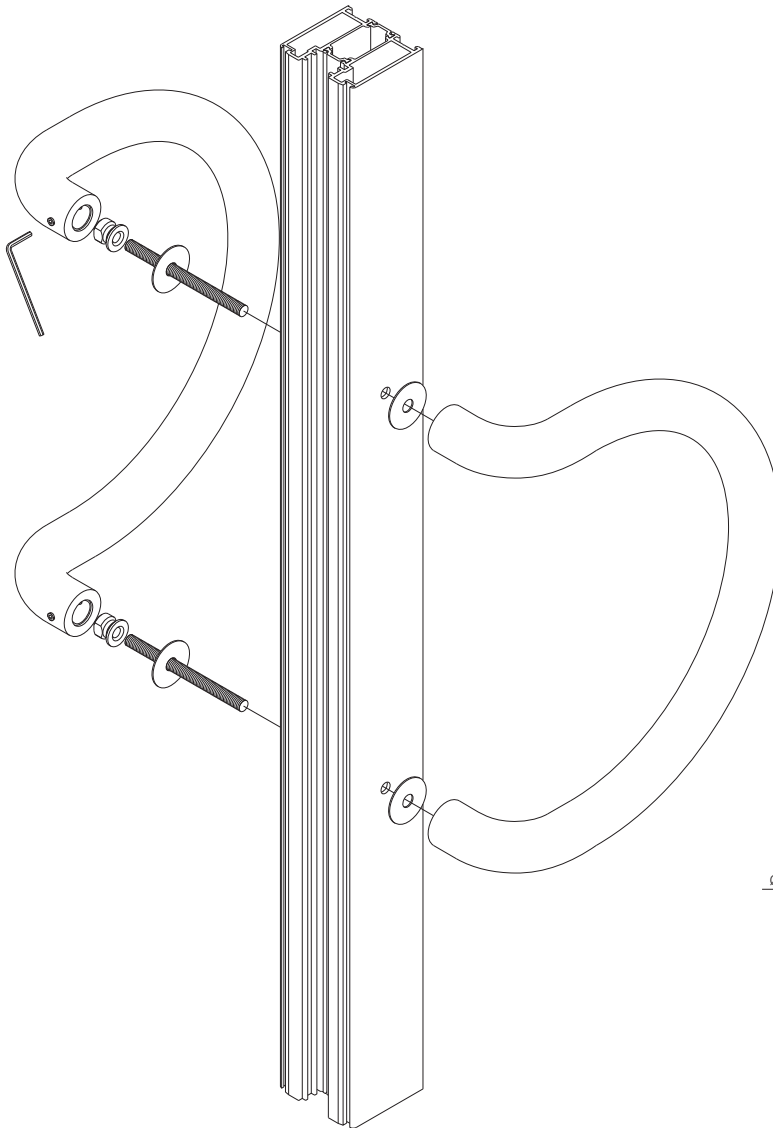

**The Parkside Group Ltd**

The Willow Centre  
17 Willow Lane, Mitcham, Surrey, CR4 4NX  
Tel: 020-8685 9685 Fax: 020-8646 5096  
Email: axim@parksidegroup.co.uk  
Web Site: www.axim.co.uk

SCALE	NTS @A4
DATE	AUGUST 2016

For scaled technical or CAD drawings,  
please contact AXIM.

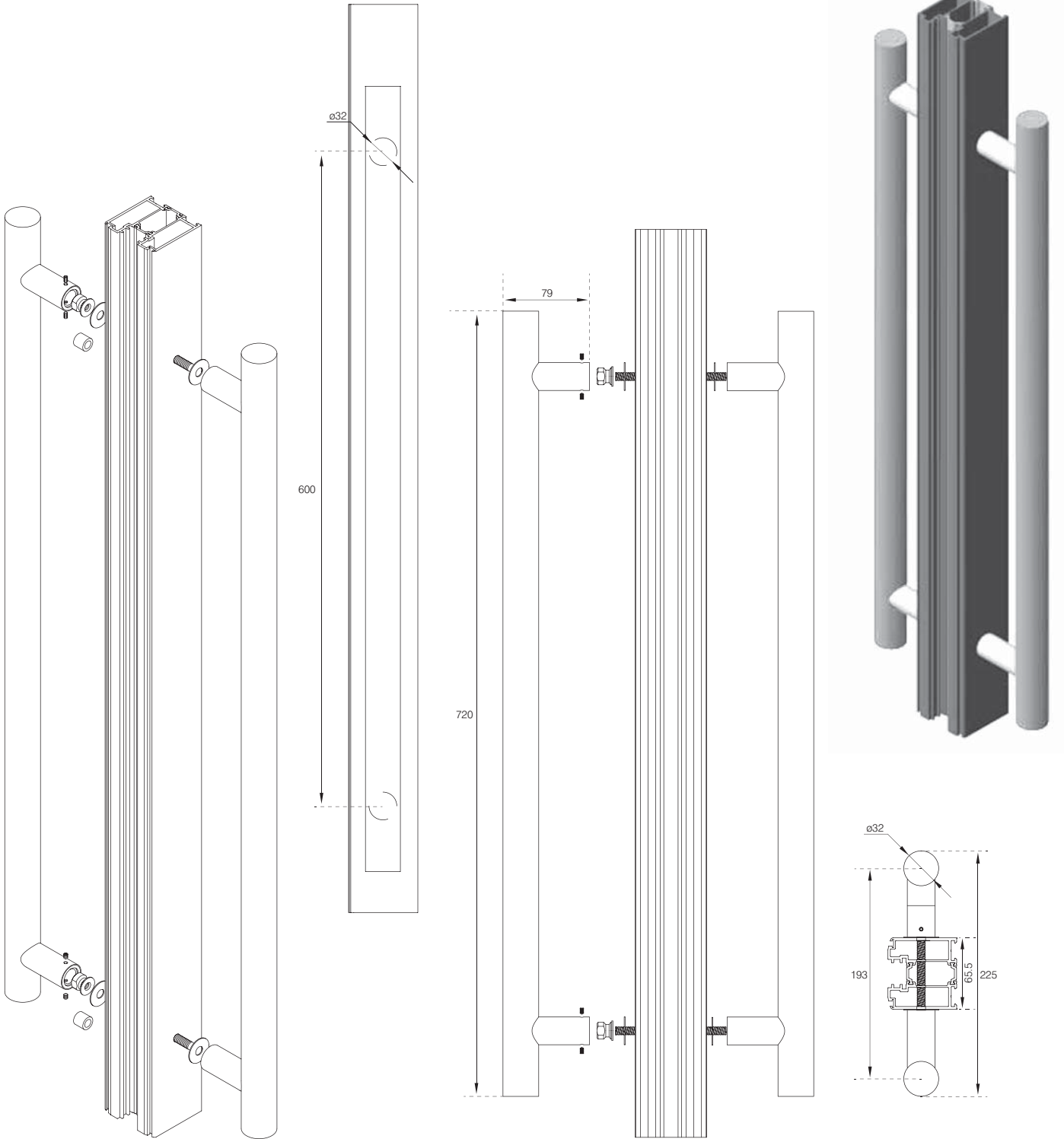

The Parkside Group Ltd

The Willow Centre  
17 Willow Lane, Mitcham, Surrey, CR4 4NX  
Tel: 020-8685 9685 Fax: 020-8646 5096  
Email: axim@parksidegroup.co.uk  
Web Site: www.axim.co.uk

SCALE	NTS @A4
DATE	JULY 2017

For scaled technical or CAD drawings,  
please contact AXIM.

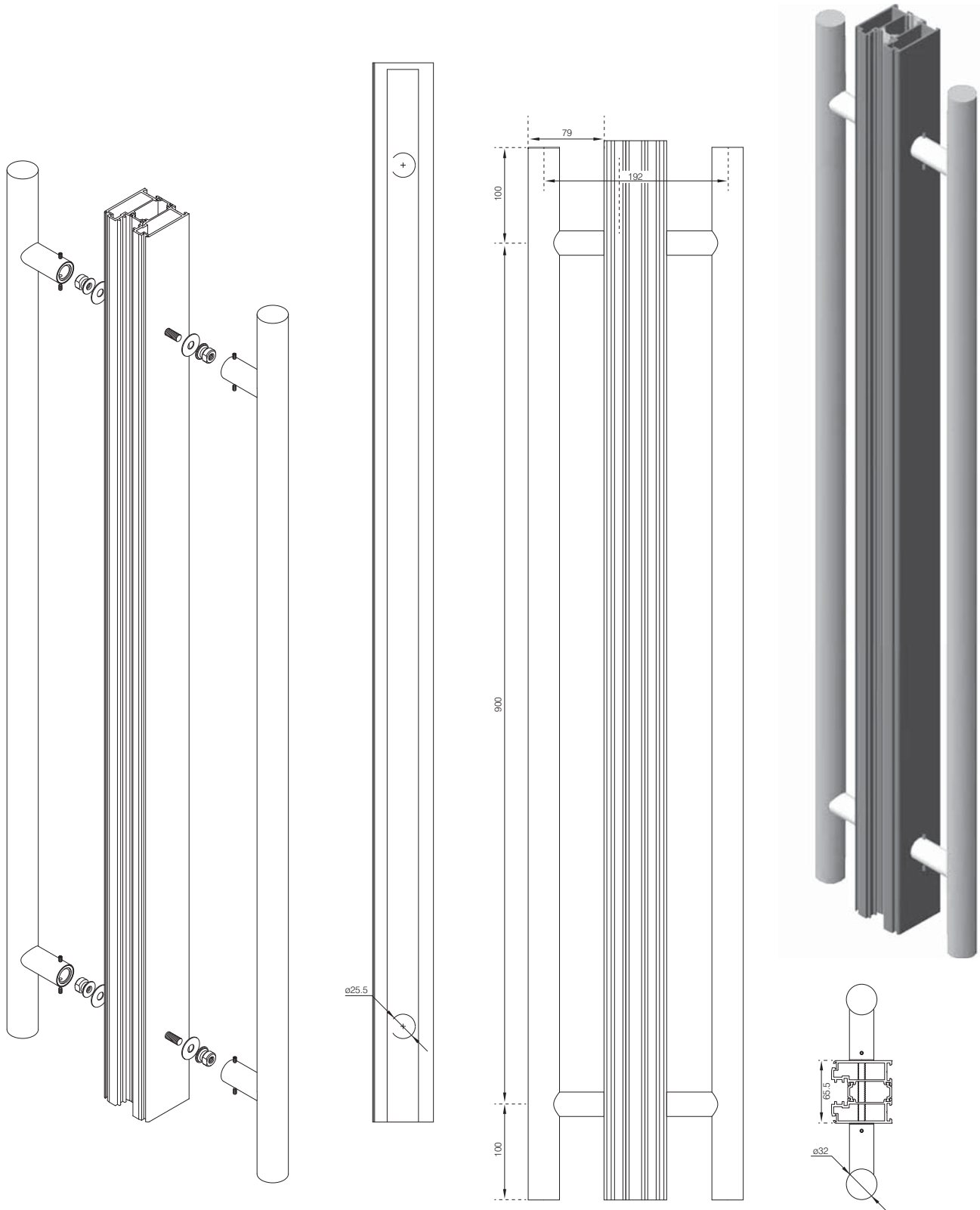

**The Parkside Group Ltd**

The Willow Centre  
17 Willow Lane, Mitcham, Surrey, CR4 4NX  
Tel: 020-8685 9685 Fax: 020-8646 5096  
Email: axim@parksidegroup.co.uk  
Web Site: www.axim.co.uk

SCALE	NTS @A4
DATE	JULY 2017
For scaled technical or CAD drawings, please contact AXIM.	

Route hole 96 x 35mm using  
Ø5mm cutter. Use 4mm  
self-tapping screws @ 105mm  
centres to secure stile.a

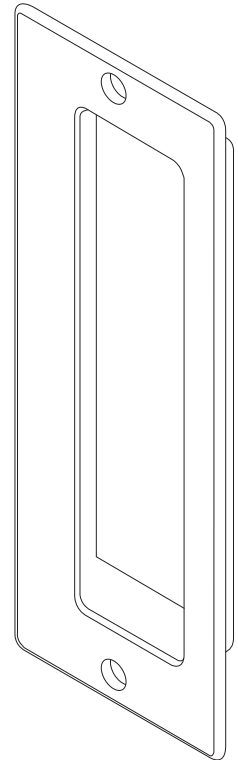
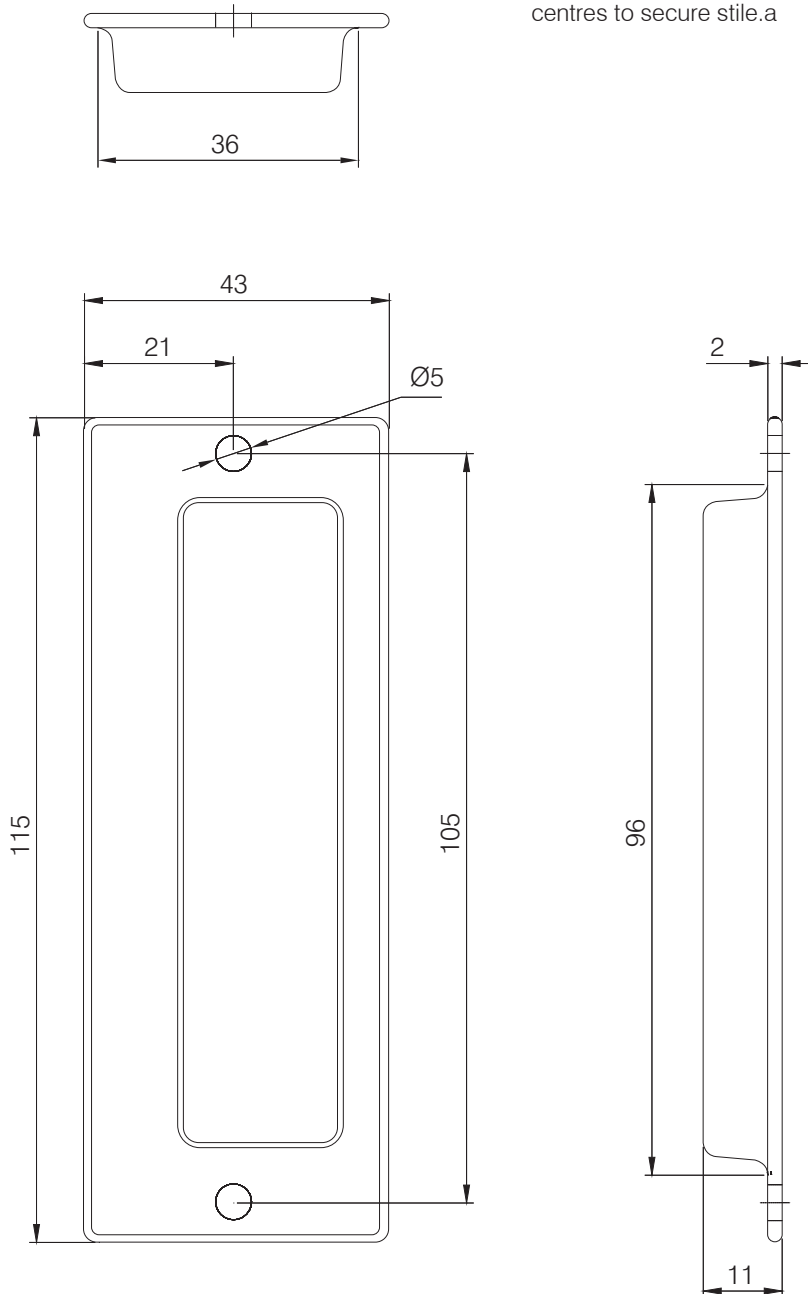

Product code:  
HD048XSSS



TITLE	<b>STAINLESS STEEL HANDLES HD-8200 AND HD-9000 SERIES</b>	SHEET No. <b>6:16</b>
SUB TITLE	<b>TECHNICAL INFORMATION</b>	

### Stainless Steel Door Handles

The main material used for the production of the Entrance handles is SUS316 material and are ideally specified for use on external door applications this material is ideally suited to heavy duty locations where the integrity of the material is a critical factor, this stainless steel is particularly good against corrosion.

However, the corrosion resistance of any stainless steel door handle is largely dependent on how clean the handle is kept. Stainless steel is not stain free ! Any contamination of the surface will impair the action of the material and can affect the surface appearance of the product.

Stainless steel is well known for its inherent corrosion resistance. The corrosion resistance of stainless steel is due to a passive film of chromium-rich oxide (caused by a reaction between the chromium in the stainless steel with the oxygen in the air). If the surface is not regularly cleaned, surface deposits will prevent the passivation process.

Therefore to retain the highest corrosion resistance and aesthetic appeal it is necessary to keep the surface of stainless steel clean.

Regular and frequent cleaning of stainless steel door handles is therefore key to preserving their appearance. For best results use a clean cloth and warm water with a mild detergent. Should any stains remain, we recommend using mild, non-scratching /abrasive Cleaner (typical household Stainless Steel Cleaning Solutions will be fine).

Dilute in warm water if needed and apply with sponges, cloths or Soft brushes. For harsher stains, a drop of vinegar in addition may help.

Please DO NOT use carbon steel brushes / carbon steel wool as these may leave particles embedded in the surface of the door handle, which can in turn show as rust.

Please note the use of scouring pads will remove the top layer of the material and will affect the Brushed appearance of the handle .

After correct cleaning of the handle, rinse in clean hot water and dry completely with a towel.

**We recommend cleaning at least once a month.** In areas where the products are used more frequently or exposed to more extreme atmospheric conditions the cleaning routine should be increased to at least once a week. If the stainless steel begins to discolour, either the cleaning regime is inadequate or in the case of swimming pool areas the environment could have deteriorated.

**Harsh environments such as Swimming Pools, Coastal / Offshore application or high pollution areas will require a more regular cleaning regime.**

If Spots appear on the surface of the product it will not be due to the stainless steel material but will be due to impurities in the surrounding water / air or indeed to external particles that have fallen onto the surface of the product, please also ensure sufficient cleaning has taken place because if there are any cleaning agents that have not been thoroughly removed from the surface it can also create this appearance.

These Spots can be removed with non abrasive cleaners that are specifically suitable for Stainless Steel material.



### The Parkside Group Ltd

The Willow Centre  
17 Willow Lane, Mitcham, Surrey, CR4 4NX  
Tel: 020-8685 9685 Fax: 020-8646 5096  
Email: axim@parksidegroup.co.uk  
Web Site: www.axim.co.uk

SCALE	NTS @A4
DATE	AUGUST 2016
For scaled technical or CAD drawings, please contact AXIM.	



**LK-1800-25**  
Mortice hook lock  
25mm backset

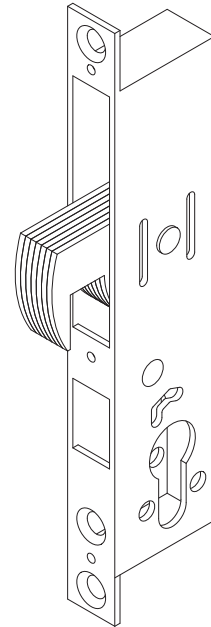
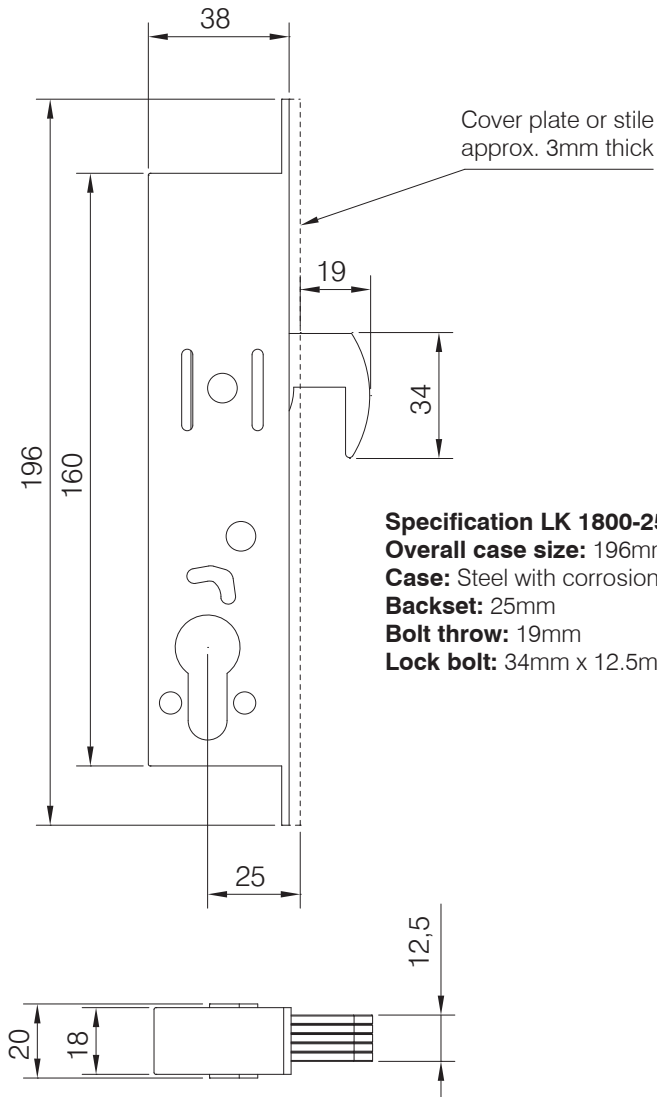

**Specification LK 1800-25**

**Overall case size:** 196mm x 18mm x 38mm

**Case:** Steel with corrosion resistant plating

**Backset:** 25mm

**Bolt throw:** 19mm

**Lock bolt:** 34mm x 12.5mm

**Accessories**

Faceplates

**LK-1801-0F** - Flat no woolpile - Silver

**LK-1801-0R** - Radius no woolpile - Silver

**LK-1801-1R** - Radius with woolpile - Silver

**LK-1802-0F** - Flat no woolpile - Silver

**LK-1802-0R** - Radius with woolpile - Silver

Cylinders

**LK-1601-3030** - Keyed to differ

**LK-1601-3030-S** - Keyed alike

**LK-1601-3030-SP** - Keyed alike in pairs

Mortice hook locks

**LK-1800-25-E** - 25mm Backset Europrofile

**LK-1800-25-R** - 25mm Backset Round Cylinder

Mounting bridges

**LK-1800-1133** - PAIR

Armoured strike

**LK-1800-52**

Trim strike

**LK-1800-51-F** - Flat

**LK-1900-51-R** - Radius

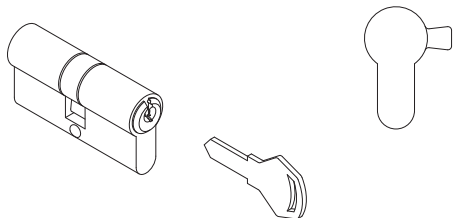

Note: See AXIM price list for alternative cylinders and finishes

**LK-1800-30**  
Mortice hook lock  
30mm backset

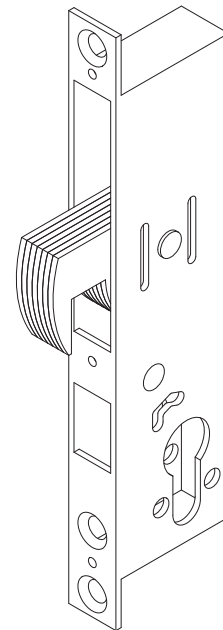
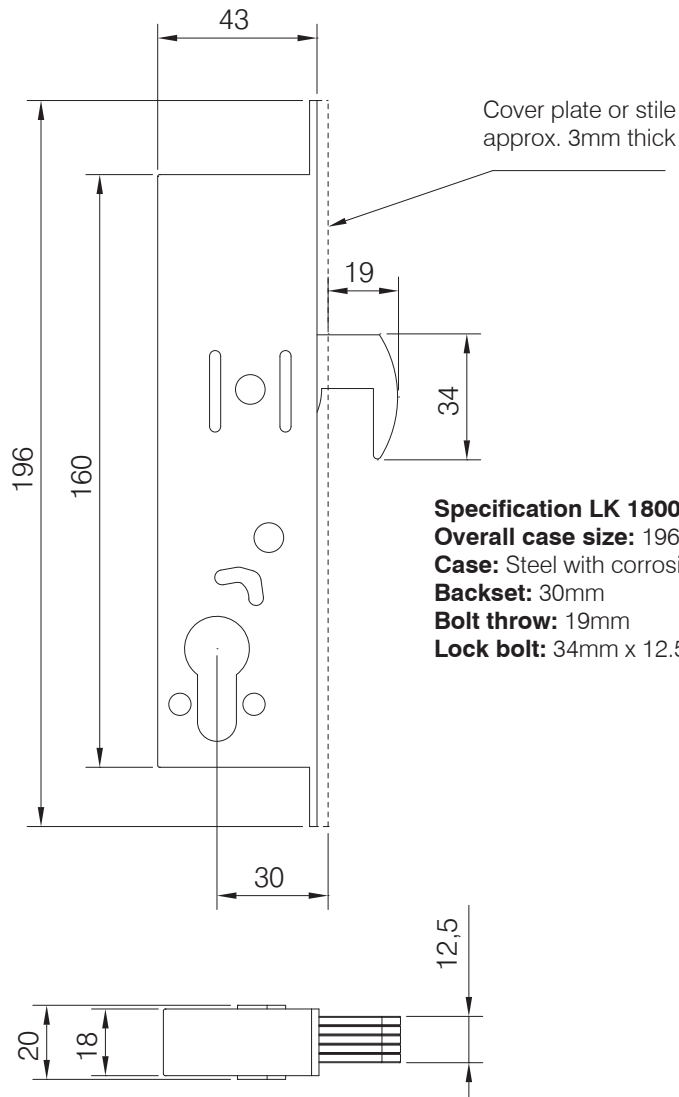

**Specification LK 1800-30**

**Overall case size:** 196mm x 18mm x 43mm

**Case:** Steel with corrosion resistant plating

**Backset:** 30mm

**Bolt throw:** 19mm

**Lock bolt:** 34mm x 12.5mm

**Accessories**

Faceplates

**LK-1801-0F** - Flat no woolpile - Silver

**LK-1801-0R** - Radius no woolpile - Silver

**LK-1801-1R** - Radius with woolpile - Silver

**LK-1802-0F** - Flat no woolpile - Silver

**LK-1802-0R** - Radius with woolpile - Silver

Cylinders

**LK-1601-3030** - Keyed to differ

**LK-1601-3030-S** - Keyed alike

**LK-1601-3030-SP** - Keyed alike in pairs

Mortice hook locks

**LK-1800-30-E** - 30mm Backset Europrofile

**LK-1800-30-R** - 30mm Backset Round Cylinder

Mounting bridges

**LK-1800-1133** - PAIR

Armoured strike

**LK-1800-52**

Trim strike

**LK-1800-51-F** - Flat

**LK-1900-51-R** - Radius

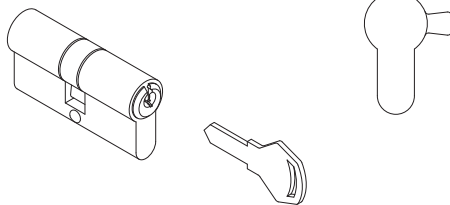

Note: See AXIM price list for alternative cylinders and finishes

**LK-1800-40**  
Mortice hook lock  
40mm backset

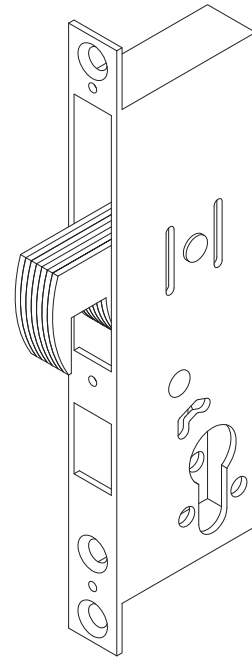
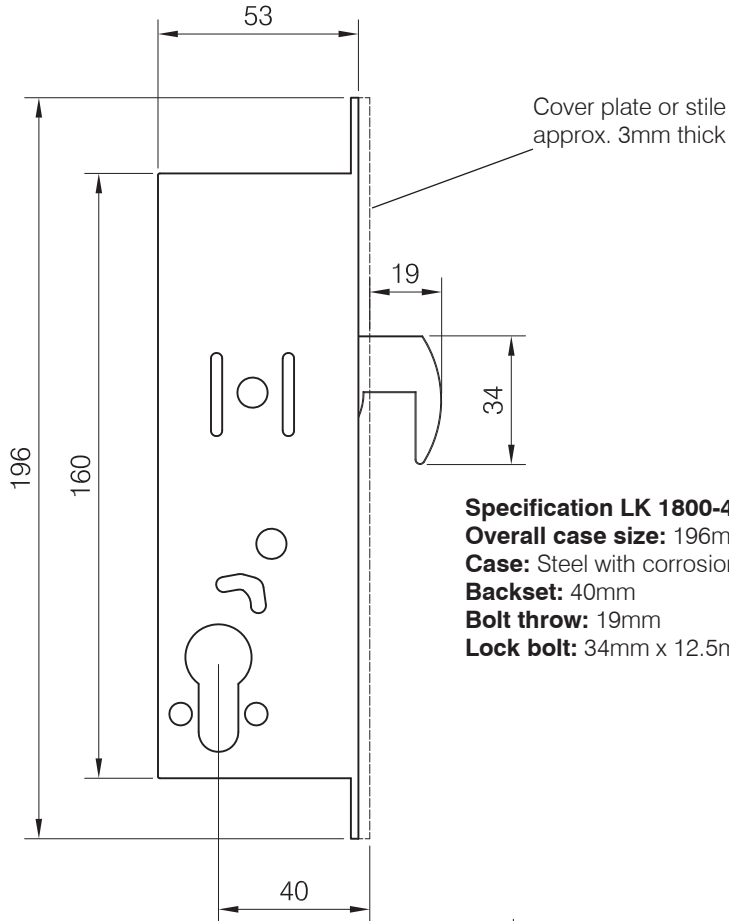

**Specification LK 1800-40**

**Overall case size:** 196mm x 18mm x 53mm

**Case:** Steel with corrosion resistant plating

**Backset:** 40mm

**Bolt throw:** 19mm

**Lock bolt:** 34mm x 12.5mm

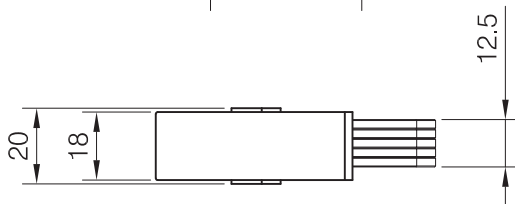

**Accessories**

Faceplates

**LK-1801-0F** - Flat no woolpile - Silver

**LK-1801-0R** - Radius no woolpile - Silver

**LK-1801-1R** - Radius with woolpile - Silver

**LK-1802-0F** - Flat no woolpile - Silver

**LK-1802-0R** - Radius with woolpile - Silver

Cylinders

**LK-1601-3030** - Keyed to differ

**LK-1601-3030-S** - Keyed alike

**LK-1601-3030-SP** - Keyed alike in pairs

Mortice hook locks

**LK-1800-40-E** - 40mm Backset Europrofile

**LK-1800-40-R** - 40mm Backset Round Cylinder

Mounting bridges

**LK-1800-1133** - PAIR

Armoured strike

**LK-1800-52**

Trim strike

**LK-1800-51-F** - Flat

**LK-1900-51-R** - Radius

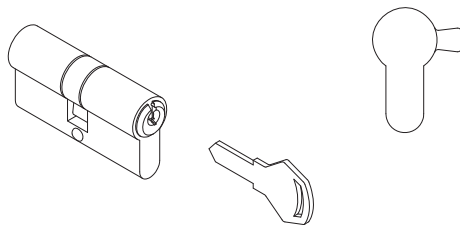

Note: See AXIM price list for alternative cylinders and finishes

**LK-1800-30-R**  
Mortice hook lock  
30mm backset  
(Rivnut Fixing)

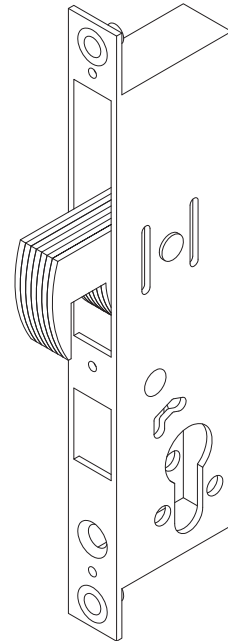
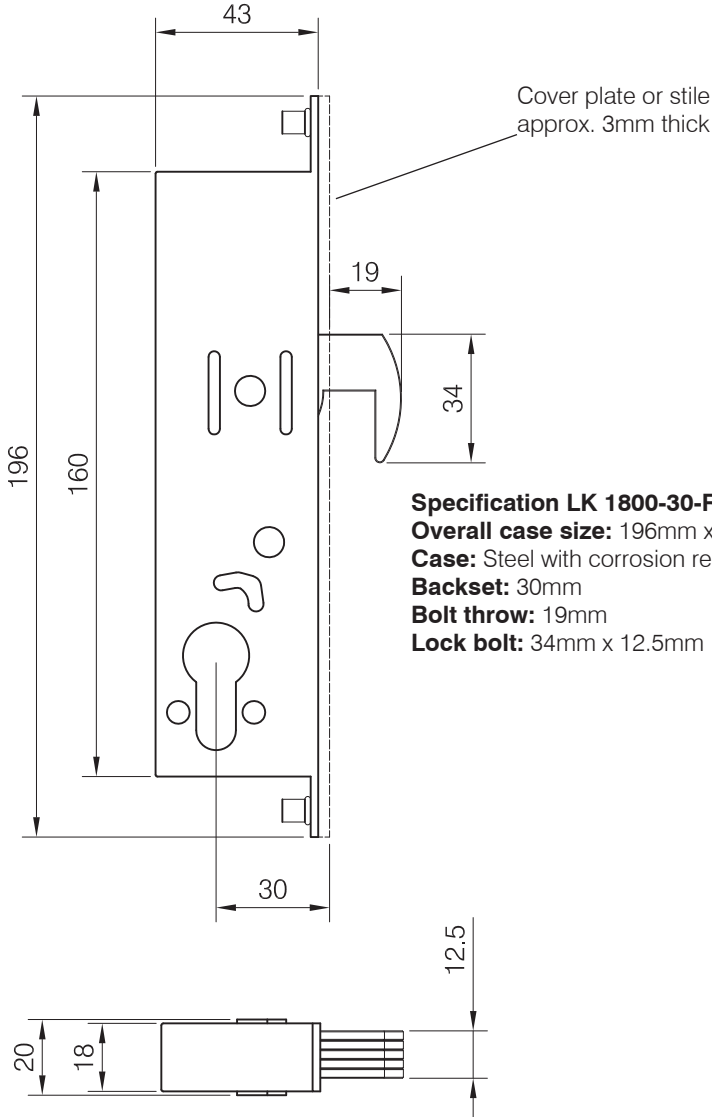

**Specification LK 1800-30-R**

**Overall case size:** 196mm x 18mm x 43mm  
**Case:** Steel with corrosion resistant plating  
**Backset:** 30mm  
**Bolt throw:** 19mm  
**Lock bolt:** 34mm x 12.5mm

**Accessories**

Faceplates

- LK-1801-0F** - Flat no woolpile - Silver
- LK-1801-0R** - Radius no woolpile - Silver
- LK-1801-1R** - Radius with woolpile - Silver
- LK-1802-0F** - Flat no woolpile - Silver
- LK-1802-0R** - Radius with woolpile - Silver

Cylinders

- LK-1601-3030** - Keyed to differ
- LK-1601-3030-S** - Keyed alike
- LK-1601-3030-SP** - Keyed alike in pairs

Mortice hook locks

- LK-1800-30-E** - 30mm Backset Europrofile
- LK-1800-30-R** - 30mm Backset Round Cylinder

Mounting bridges

- LK-1800-1133** - PAIR

Armoured strike

- LK-1800-52**

Trim strike

- LK-1800-51-F** - Flat
- LK-1900-51-R** - Radius

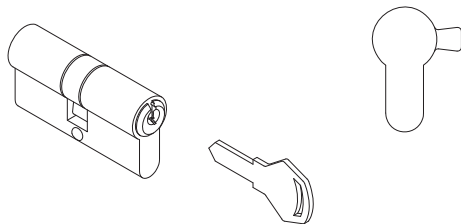

Note: See AXIM price list for alternative cylinders and finishes



**The Parkside Group Ltd**

The Willow Centre  
 17 Willow Lane, Mitcham, Surrey, CR4 4NX  
 Tel: 020-8685 9685 Fax: 020-8646 5096  
 Email: axim@parksidegroup.co.uk  
 Web Site: www.axim.co.uk

SCALE	NTS @A4
DATE	JULY 2017
For scaled technical or CAD drawings, please contact AXIM.	

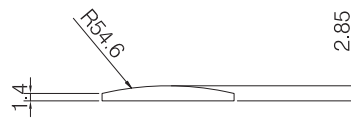
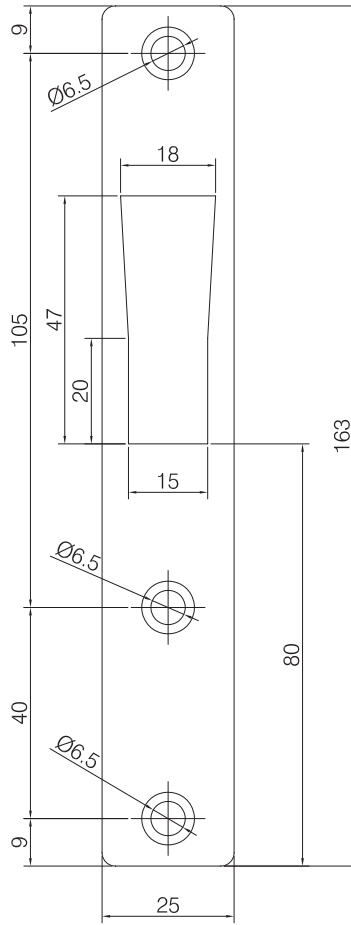

LK-1800-51-R (Radiused)  
AXIM trim strike plate

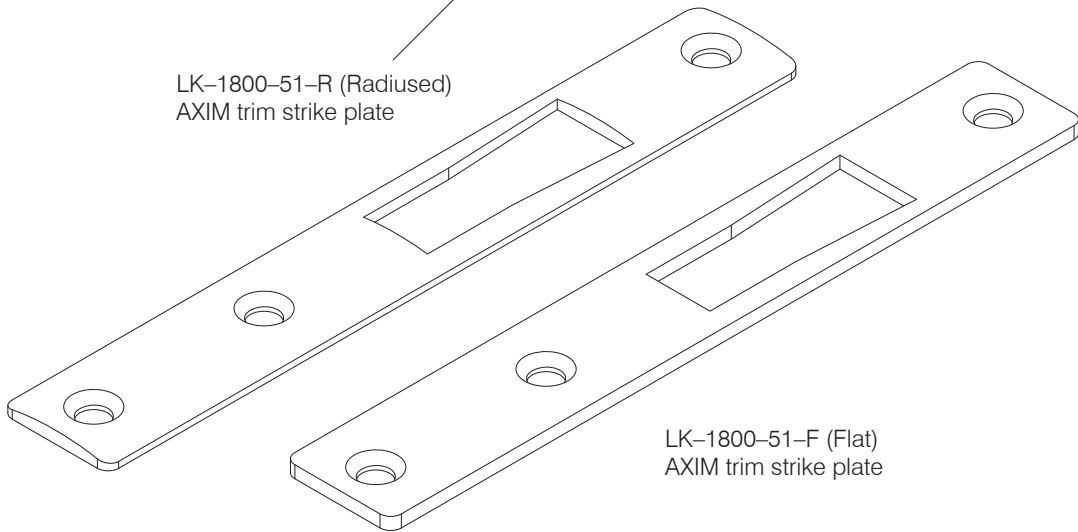

LK-1800-51-F (Flat)  
AXIM trim strike plate



The Parkside Group Ltd

The Willow Centre  
17 Willow Lane, Mitcham, Surrey, CR4 4NX  
Tel: 020-8685 9685 Fax: 020-8646 5096  
Email: axim@parksidegroup.co.uk  
Web Site: www.axim.co.uk

SCALE	NTS @A4
DATE	JULY 2017

For scaled technical or CAD drawings,  
please contact AXIM.

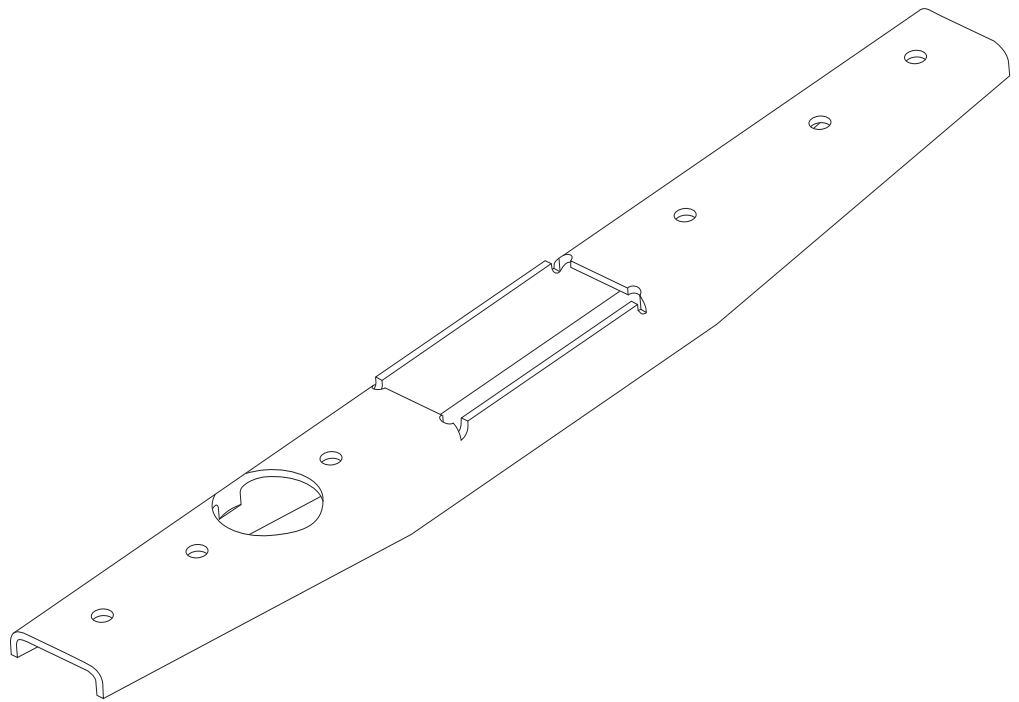
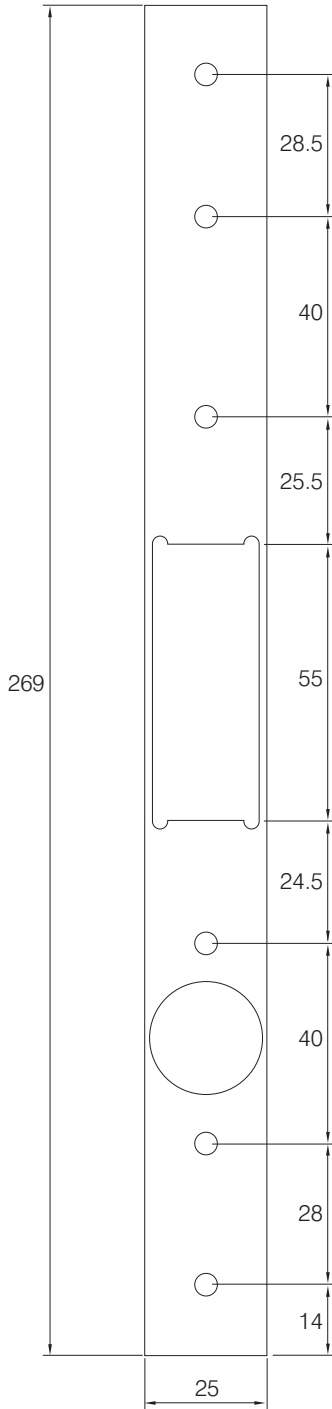

**The Parkside Group Ltd**

The Willow Centre  
 17 Willow Lane, Mitcham, Surrey, CR4 4NX  
 Tel: 020-8685 9685 Fax: 020-8646 5096  
 Email: axim@parksidegroup.co.uk  
 Web Site: www.axim.co.uk

SCALE	NTS @A4
DATE	MARCH 2014

For scaled technical or CAD drawings,  
 please contact AXIM.

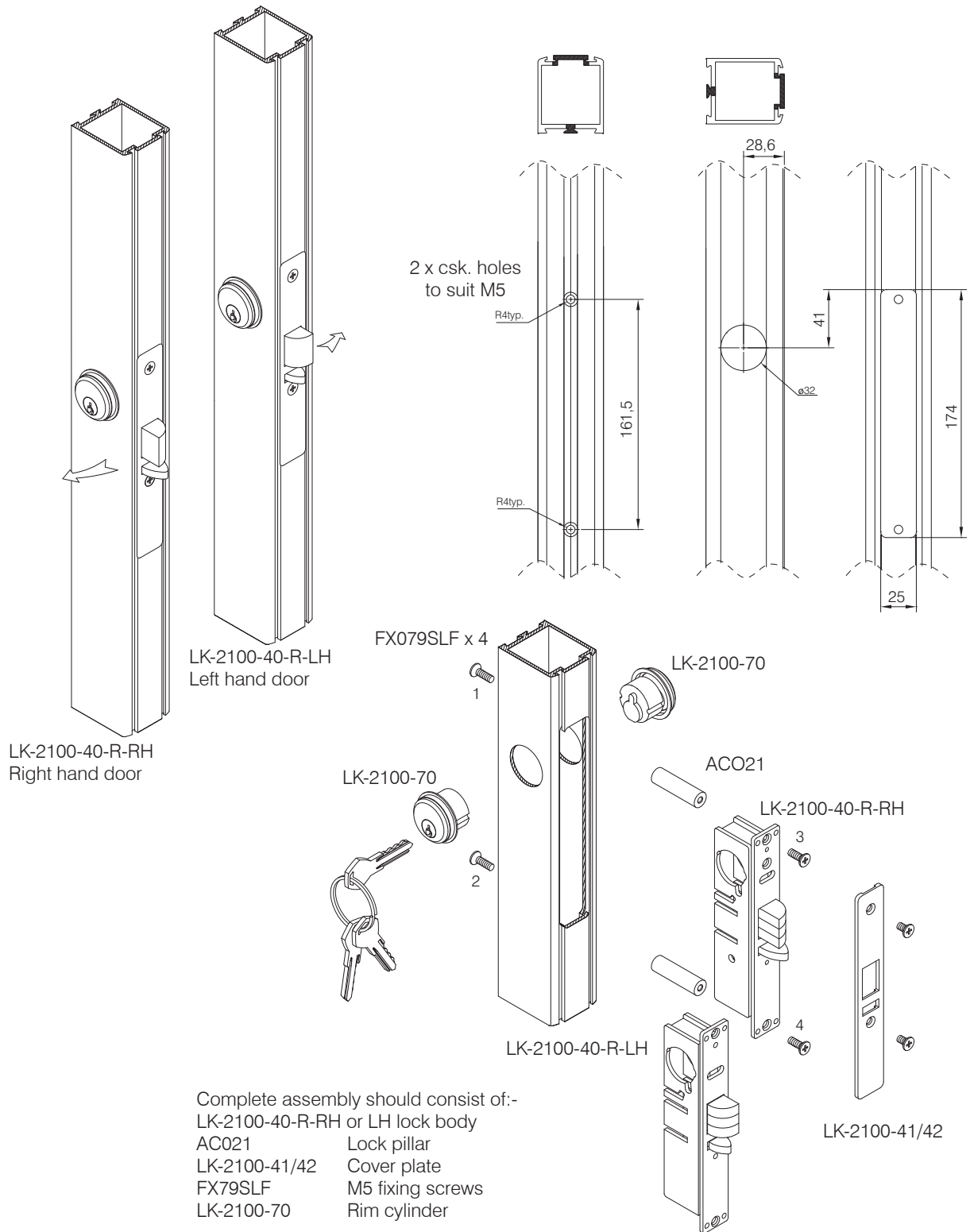

**The Parkside Group Ltd**

The Willow Centre  
17 Willow Lane, Mitcham, Surrey, CR4 4NX  
Tel: 020-8685 9685 Fax: 020-8646 5096  
Email: axim@parksidegroup.co.uk  
Web Site: www.axim.co.uk

SCALE	NTS @A4
DATE	AUGUST 2016
For scaled technical or CAD drawings, please contact AXIM.	

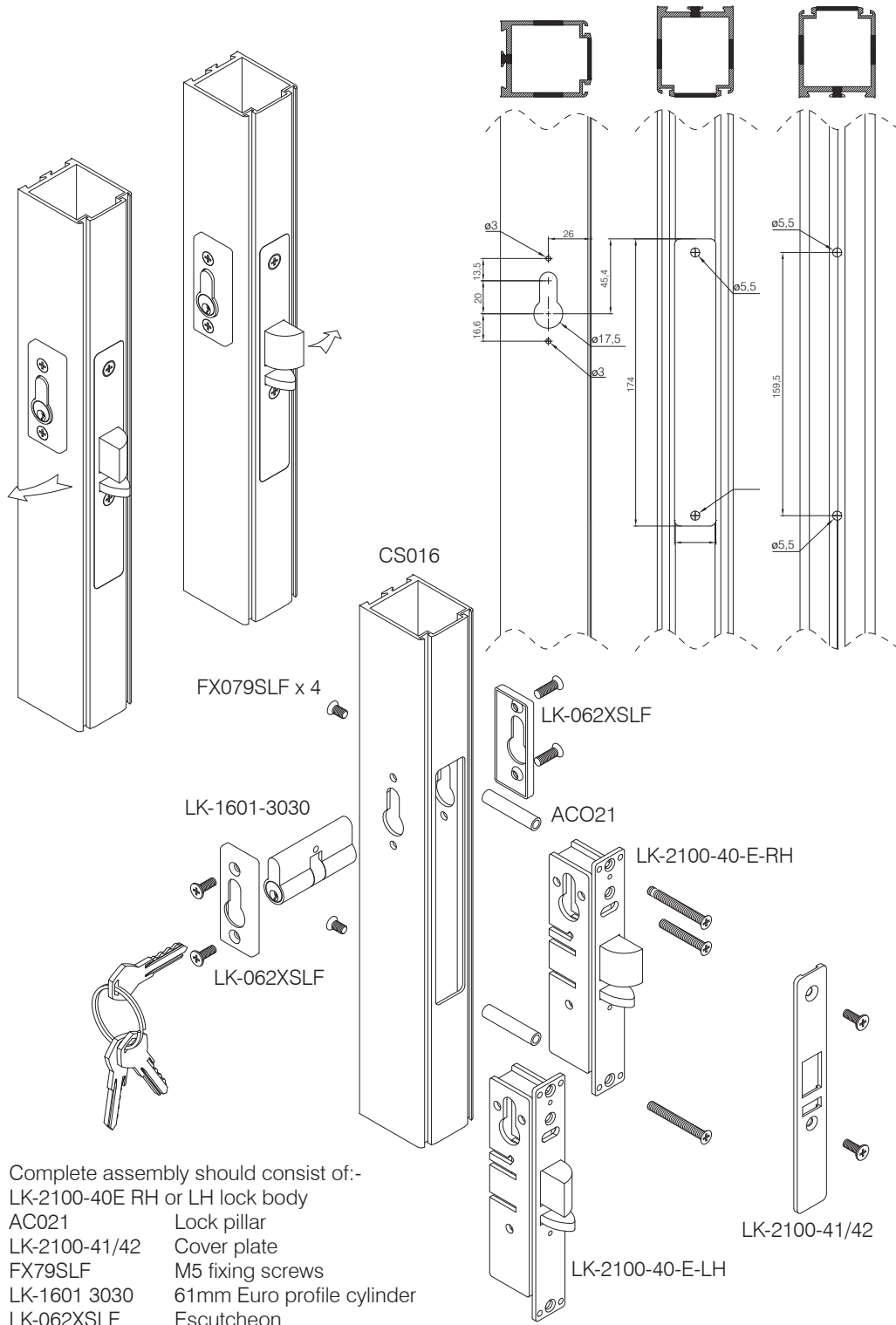



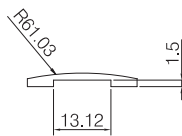
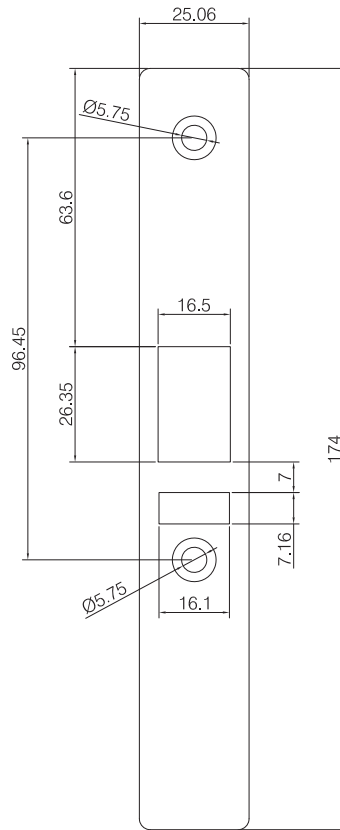
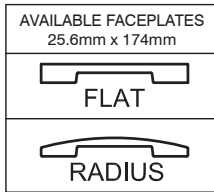

LK-2100-42 (Radiused)  
AXIM trim strike plate

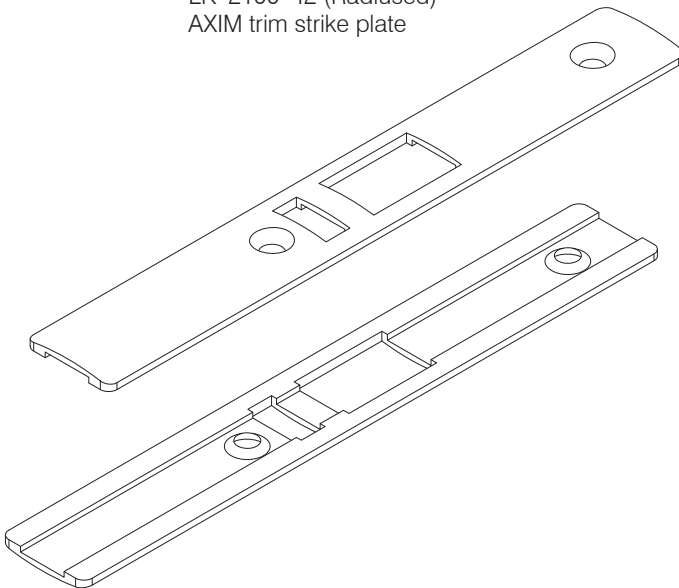

LK-2100-41 (Flat)  
AXIM trim strike plate

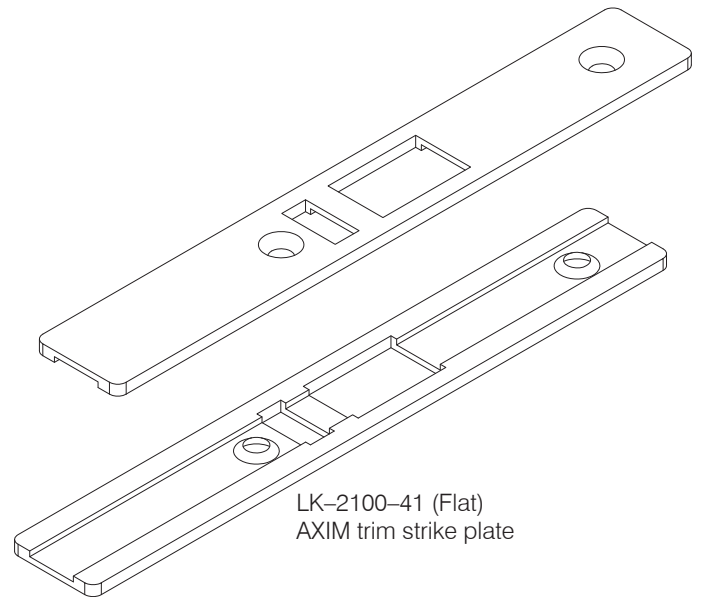

The Parkside Group Ltd

The Willow Centre  
17 Willow Lane, Mitcham, Surrey, CR4 4NX  
Tel: 020-8685 9685 Fax: 020-8646 5096  
Email: axim@parksidegroup.co.uk  
Web Site: www.axim.co.uk

SCALE	NTS @A4
DATE	JULY 2017

For scaled technical or CAD drawings,  
please contact AXIM.

The Fully reversible LK-2100 Standard duty deadlatch range offers flexibility of traffic control during and after business hours.

Fully Reversible Latchbolt Without the need to open the deadlatch case. (Full Instructions included with the product)

**Latchbolt Holdback**

A reverse Turn of the key while the bolt is held retracted retains the latchbolt in the case, This allows two-way traffic for ideal use in hospitals, banks, shops and any other commercial buildings. which may require :

Free access and exit at certain times, and  
Controlled access and free exit at other times.

The Axim LK-2100 deadlatch product is an ideal product to be used and specified along with the Axim ES-2100 Electric Strike range offering a remote access control solution for doors.

Alternatively the LK-2100 range can be equally installed with the LK-2100-6515 (48mm) and the LK-2100-7515 (72mm). - see overleaf for ordering codes

**Key Points**

The Axim Deadlatch is an all metal case complete with the main latch body structure to prevent unauthorised case entry.

The LK-2100 is available with Flat face or Radius face faceplates that are Ordered as separate items - see overleaf for ordering codes.

Fully Reversible Latchbolt without opening the Deadlatch case.

**Related Hardware**

LK2100 - E  
Reversible  
Euro Profile Deadlatch

ES2100  
Electric Strike

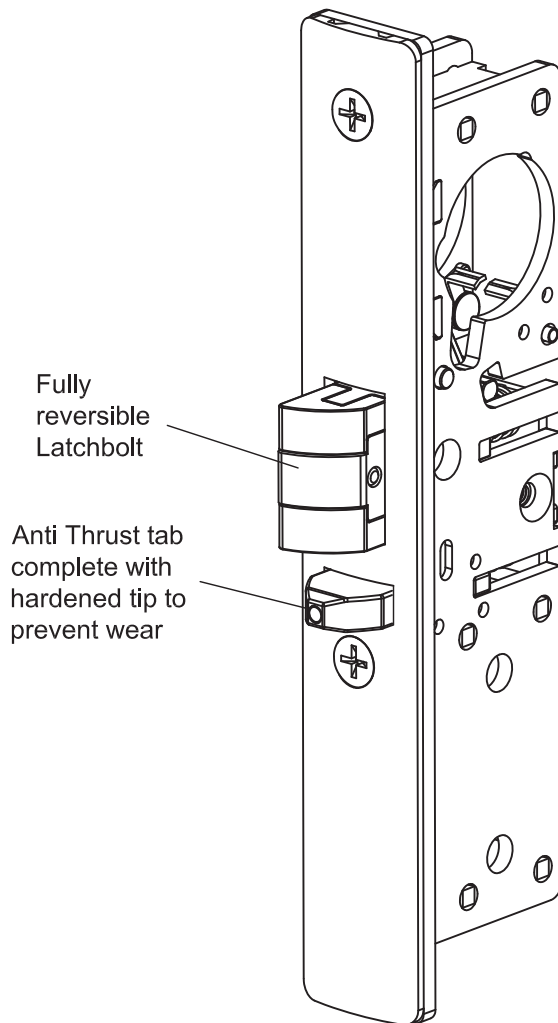

A Nylon Insert is added to the latchbolt to prevent friction in operation.

Suitable for use on Aluminium Doors

Guarantee:  
Axim Products are guaranteed for 30 months against defects in material and / or workmanship. This guarantee is Void if the product has been incorrectly specified or installed.



The Parkside Group Ltd

The Willow Centre  
17 Willow Lane, Mitcham, Surrey, CR4 4NX  
Tel: 020-8685 9685 Fax: 020-8646 5096  
Email: axim@parksidegroup.co.uk  
Web Site: www.axim.co.uk

SCALE	NTS @A4
DATE	AUGUST 2016
For scaled technical or CAD drawings, please contact AXIM.	

It is recommended for Deadlatch that the Fixing Tab (item LK-2100-77) are included in the installation. Please order separately.

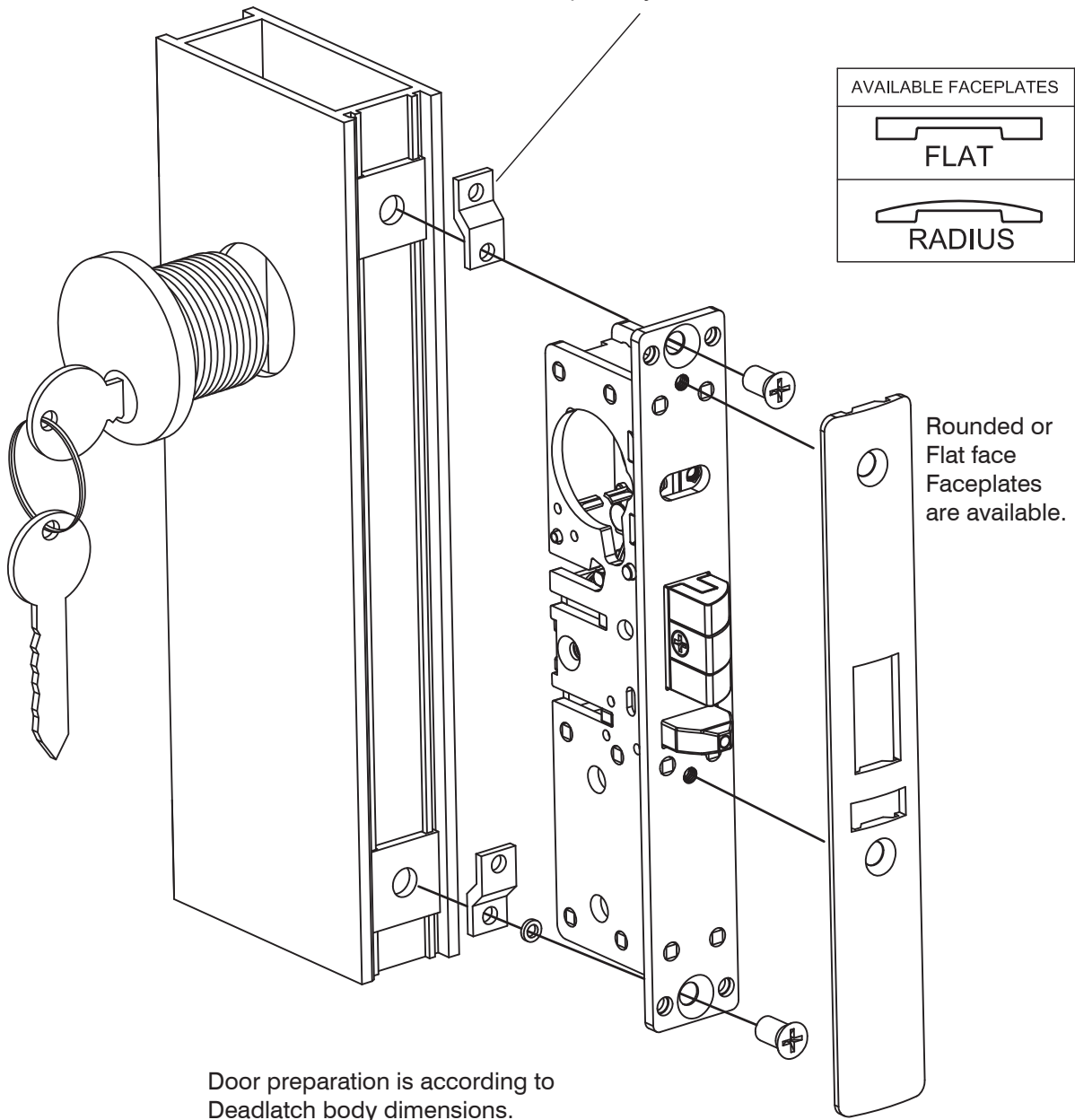

Door preparation is according to Deadlatch body dimensions.



The Parkside Group Ltd

The Willow Centre  
17 Willow Lane, Mitcham, Surrey, CR4 4NX  
Tel: 020-8685 9685 Fax: 020-8646 5096  
Email: axim@parksidegroup.co.uk  
Web Site: www.axim.co.uk

SCALE	NTS @A4
DATE	AUGUST 2016

For scaled technical or CAD drawings, please contact AXIM.

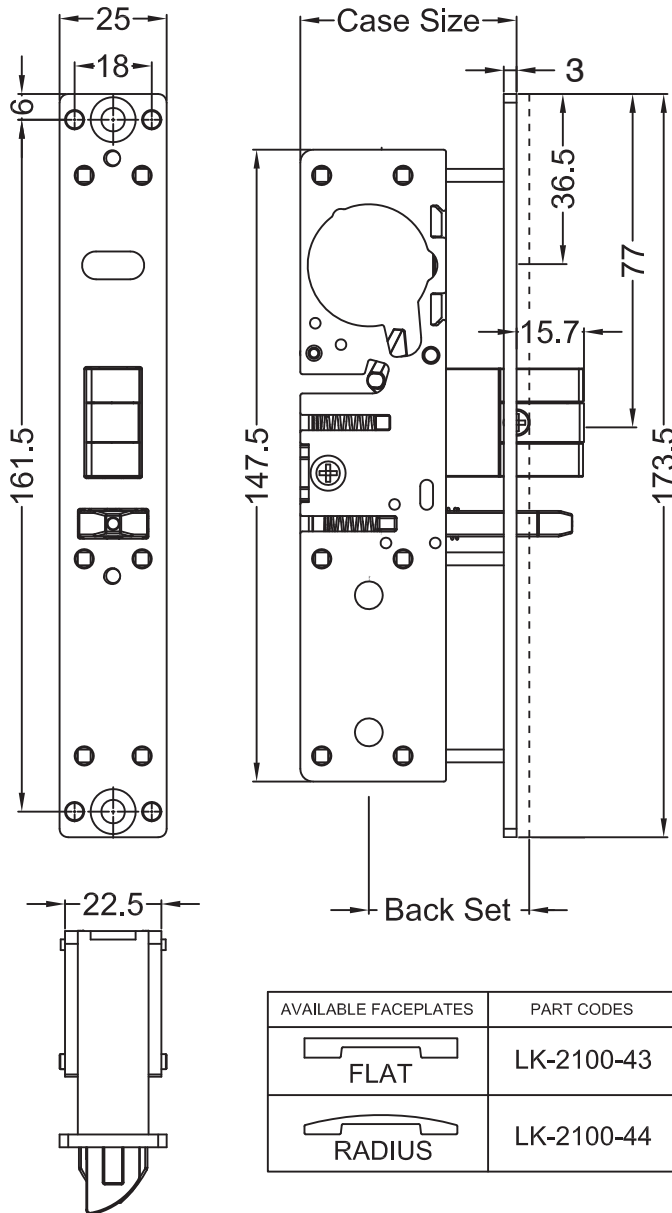

**Case Size & Backset vary depending on version:**

**Backset Options**

25mm (31/32") Backset  
28mm (1-1/8") Backset  
38mm (1-1/2") Backset

**Case:**

Steel with corrosion resistant plating.



**Latchbolt:**

Fully Reversible Latchbolt - Without the need to Open the case.  
Latchbolt complete with Hardened Steel Internal Pins.

**Faceplate:**

173.5 x 25mm  
Aluminium material,  
Finish: Matt / Satin Anodised Aluminium.

Faceplate: -----

AVAILABLE FACEPLATES	PART CODES
 FLAT	LK-2100-43
 RADIUS	LK-2100-44

### Ordering Information

LK-2100-25-E	Euro Profile Deadlatch Case (24.6mm Backset)
LK-2100-28-E	Euro Profile Deadlatch Case (28.6mm Backset)
LK-2100-38-E	Euro Profile Deadlatch Case (38.1mm Backset)
LK-2100-25-R	Screw in Cylinder Deadlatch Case (24.6mm Backset)
LK-2100-28-R	Screw in Cylinder Deadlatch Case (28.6mm Backset)
LK-2100-38-R	Screw in Cylinder Deadlatch Case (38.1mm Backset)
LK-2100-43	Axim Misc - Flat face plate
LK-2100-44	Axim Misc - Radius face plate
LK-2100-6515	48mm Strike for LK-2100 Reversible Deadlatch
LK-2100-7515	72mm Strike for LK-2100 Reversible Deadlatch
LK-2100-77	Fixing Tab Kit

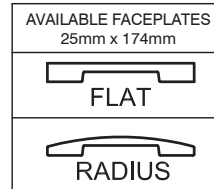
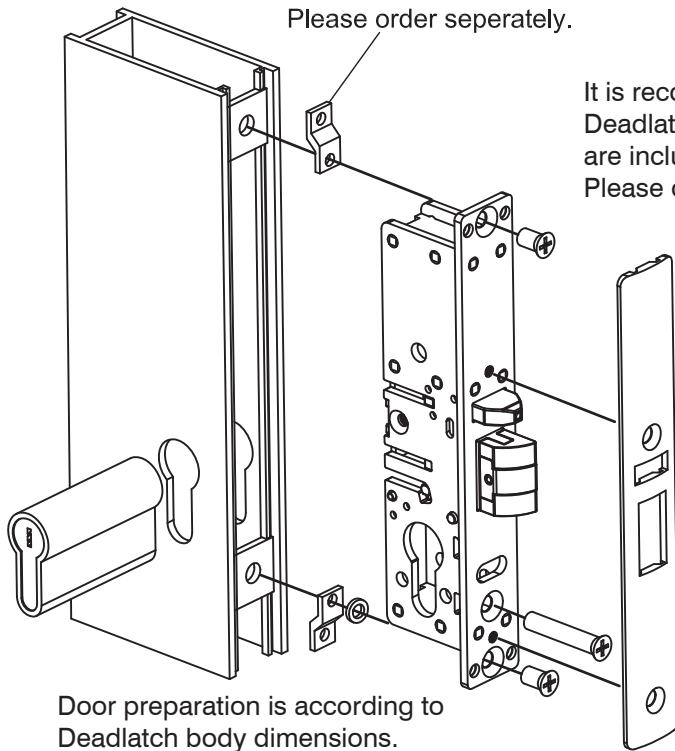

Door preparation is according to Deadlatch body dimensions.

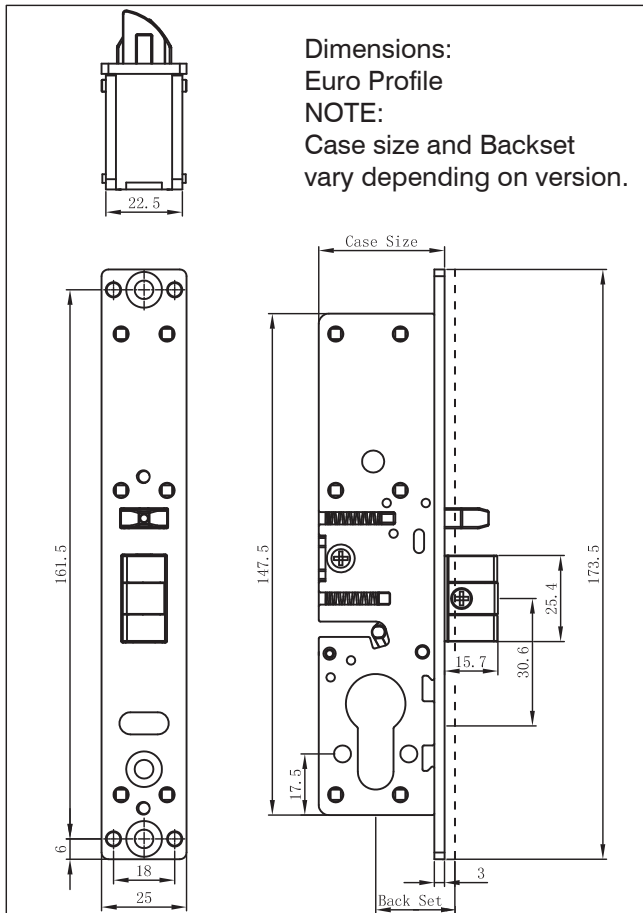

Faceplate: -----



**The Parkside Group Ltd**

The Willow Centre  
17 Willow Lane, Mitcham, Surrey, CR4 4NX  
Tel: 020-8685 9685 Fax: 020-8646 5096  
Email: axim@parksidegroup.co.uk  
Web Site: www.axim.co.uk

SCALE	NTS @A4
DATE	DECEMBER 2017

For scaled technical or CAD drawings, please contact AXIM.

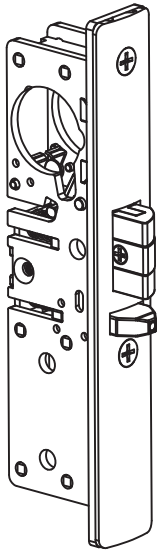

**PLEASE NOTE**  
**This product Is Reversible**  
**To Suit Left Hand Or Right Hand**  
**For Handing**

**Do Not open the case**

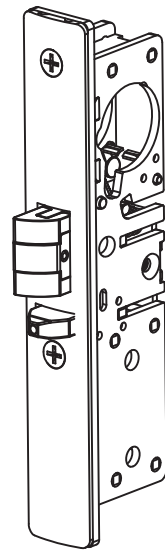

1)

Depress the Latchbolt until the screw in the Side of the Latchbolt can be seen through the hole in the Deadlatch case (larger backset versions allow easier access to this screw).

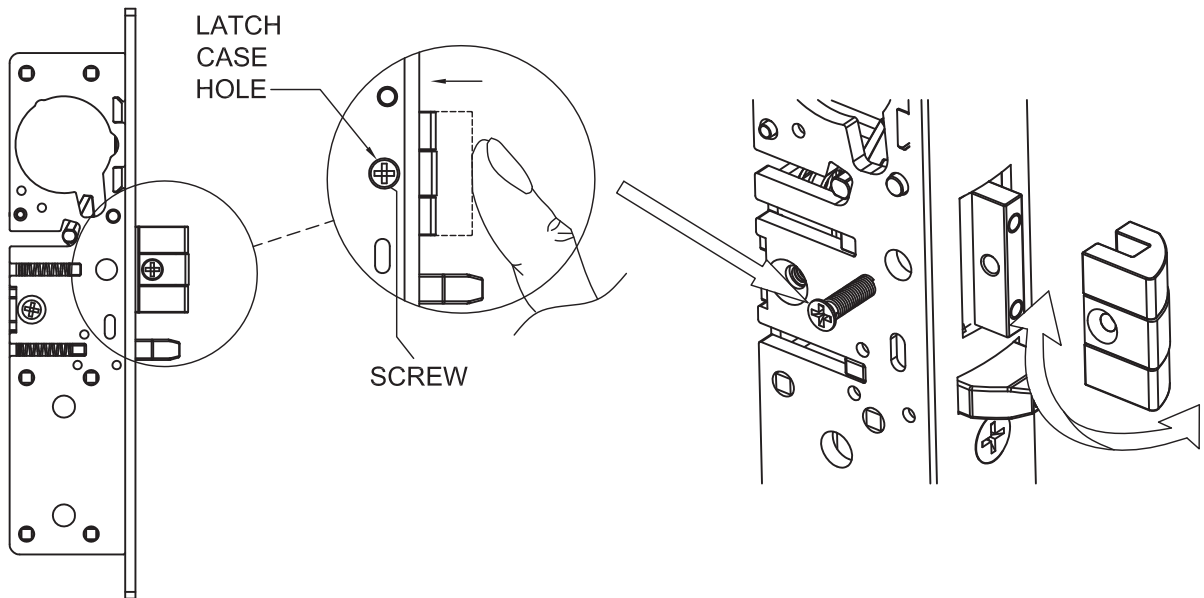

2) Remove the Machine Screw to allow the Latchbolt to be removed.

3) Reverse the Latchbolt and re install ensuring that the screw is replaced securely.

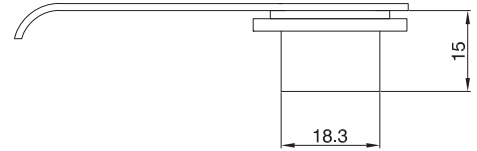
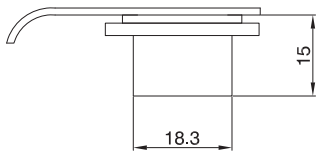
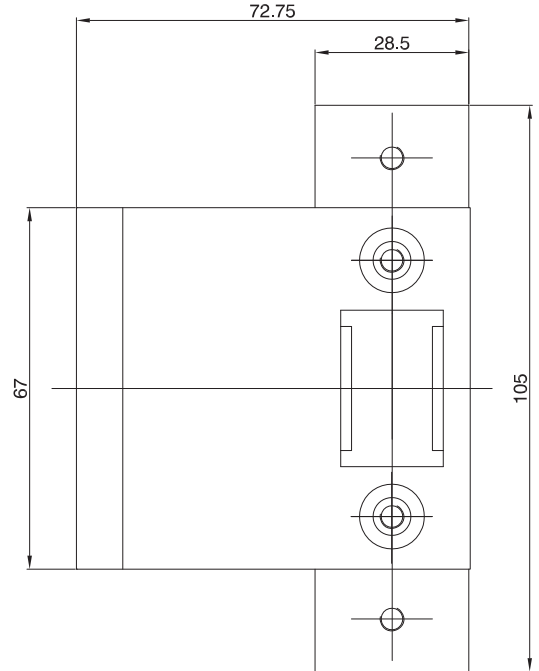
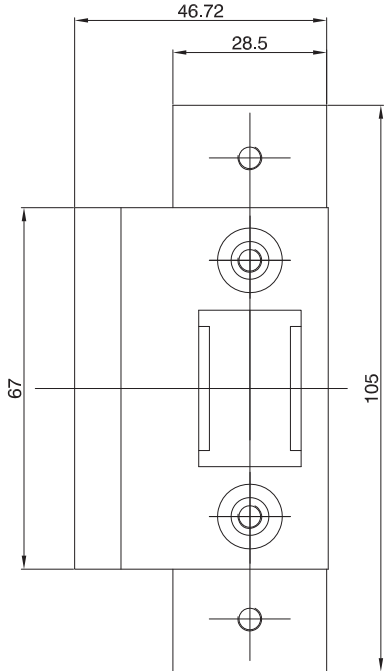

**LK-2100-6515**  
**Strike Plate - Flat 48mm**

**LK-2100-7515**  
**Strike Plate - Flat 72mm**

The LK-2100 range can be installed with the LK-2100-6515 flat 48mm strike, or the LK-2100-7515 or the flat 72mm strike.



**The Parkside Group Ltd**

The Willow Centre  
17 Willow Lane, Mitcham, Surrey, CR4 4NX  
Tel: 020-8685 9685 Fax: 020-8646 5096  
Email: axim@parksidegroup.co.uk  
Web Site: www.axim.co.uk

SCALE	NTS @A4
DATE	AUGUST 2016
For scaled technical or CAD drawings, please contact AXIM.	

The Axim Electric Strike range is an access control device used for remote access control for doors fitted with the Axim LK-2100 deadlatch product.

The Electric Strike replaces the standard fixed strikeplate of the deadlatch.

The ES-2100 is supplied with a flat faceplate for installation into a frame of a single leaf door or the inactive leaf of a pair of doors.

Supplied as Fail Safe or Fail Secure

Note: A fail-safe electric strike can be converted to a fail-secure electric strike (And Vice Versa) without any additional components or specialised tools.

**Key Points**

Suitable for use on Aluminium Doors  
Tested to 500,000 Cycles

Powered by Internal Solenoid

The compact mechanism fits into an Non Handed aluminium jamb section as shallow as 44.45mm.

Electrical actuation unlocks the strike jaw, therefore releasing the latchbolt without having to operate the latch

Axim Products are guaranteed for 30 months against defects in material and / or manually workmanship. This guarantee is Void if the product has been incorrectly specified or installed, or has been damaged due to incorrect use.

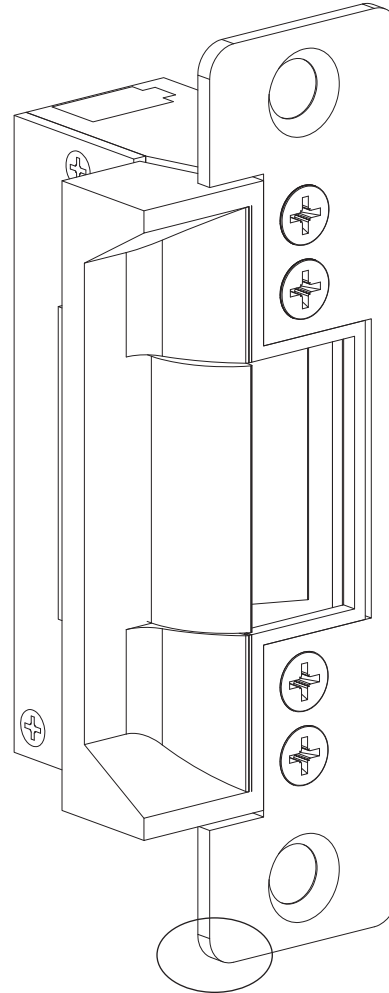

Rounded corners to assist installation

**Related Hardware**

LK2100 - E  
Reversible  
Euro Profile Deadlatch

ES2100 - R  
Electric Strike



**The Parkside Group Ltd**

The Willow Centre  
17 Willow Lane, Mitcham, Surrey, CR4 4NX  
Tel: 020-8685 9685 Fax: 020-8646 5096  
Email: axim@parksidegroup.co.uk  
Web Site: www.axim.co.uk

SCALE	NTS @A4
DATE	AUGUST 2016
For scaled technical or CAD drawings, please contact AXIM.	



**Current Draw:**

12vDC = 260mA  
24vDC = 150mA . 24VAC: 260mA

**Voltage Tolerance:**

DC Intermittent and Continuous units are silent  
AC intermittent units make a "Buzz" sound on operation.

**Application**

Fail - Safe or Fail Secure  
Note: DC Power supply required for Fail Safe Operation.

**Maximum Holding Force**

500kgs

**Case Detail:**

85.6mm x 28.6mm x 41.6mm  
Zinc Aluminium Alloy Material

**Faceplate:**

123.7mm x 31.8mm - Flat Design, Aluminium material,  
Finish: Brushed / Satin Anodised Aluminium.

**Mechanism Design:**

Stainless Steel Internal Blocking Mechanism.

**Strike Aperture Detail:**

36.5mm (Length) x 15.9mm (Width) x 12.7mm (Depth)  
Stainless Steel retaining jaw.

**Suitable Door Gap:**

Min. 3mm (1/8") Operational 3-5mm

**Testing:**

Cycle tested to exceed 500,000 cycles  
ANSI / BHMA 156.5 Grade 1  
UL Listed for burglary resistance  
CE Marked - Electrical

**Sub Cover - (Extension Lip)**

Standard Product Supplied to suit a 44.45mm door thickness,  
that closes flush with frame. For Extended "Bolt on" extension  
Lips see left hand table:

PART NO.	A (mm)	B (mm)
ES-2100-381	38.1	11.3
ES-2100-414	41.4	14.6
ES-2100-445	44.5	17.7
ES-2100-478	47.8	21
ES-2100-508	50.8	24
ES-2100-541	54.1	27.3
ES-2100-572	57.2	30.4
ES-2100-605	60.5	33.7
ES-2100-635	63.5	36.7
ES-2100-668	66.8	40
ES-2100-699	69.9	43.1
ES-2100-732	73.2	46.4
ES-2100-762	76.2	49.4

**Ordering Info**

ES-2100-12VFSAF	Electric Strike 12VDC Fail Safe
ES-2100-12VFSEC	Electric Strike 12VDC Fail Secure
ES-2100-24VFSAF	Electric Strike 24VDC Fail Safe
ES-2100-24VFSEC	Electric Strike 24VDC Fail Secure

**Dimensioned Elevations**

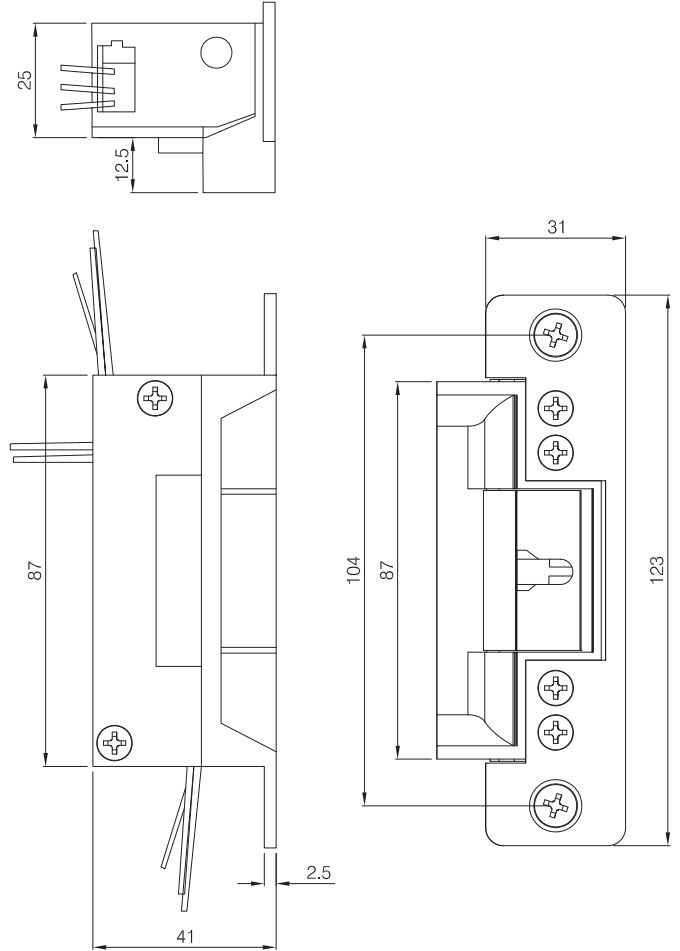

**Sub Cover - (Extension Lip) Detail**

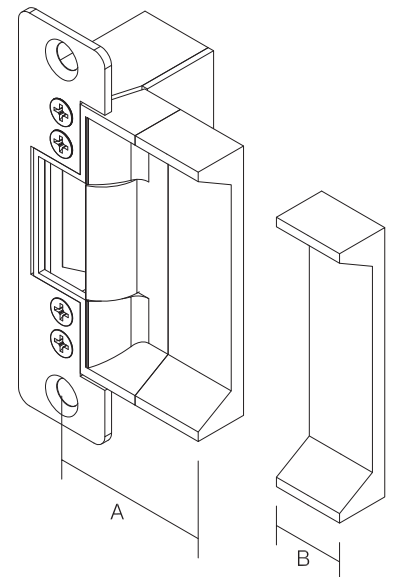

**The Parkside Group Ltd**

The Willow Centre  
17 Willow Lane, Mitcham, Surrey, CR4 4NX  
Tel: 020-8685 9685 Fax: 020-8646 5096  
Email: axim@parksidegroup.co.uk  
Web Site: www.axim.co.uk

SCALE	NTS @A4
DATE	AUGUST 2017
For scaled technical or CAD drawings, please contact AXIM.	

**Typical Installation Detail**

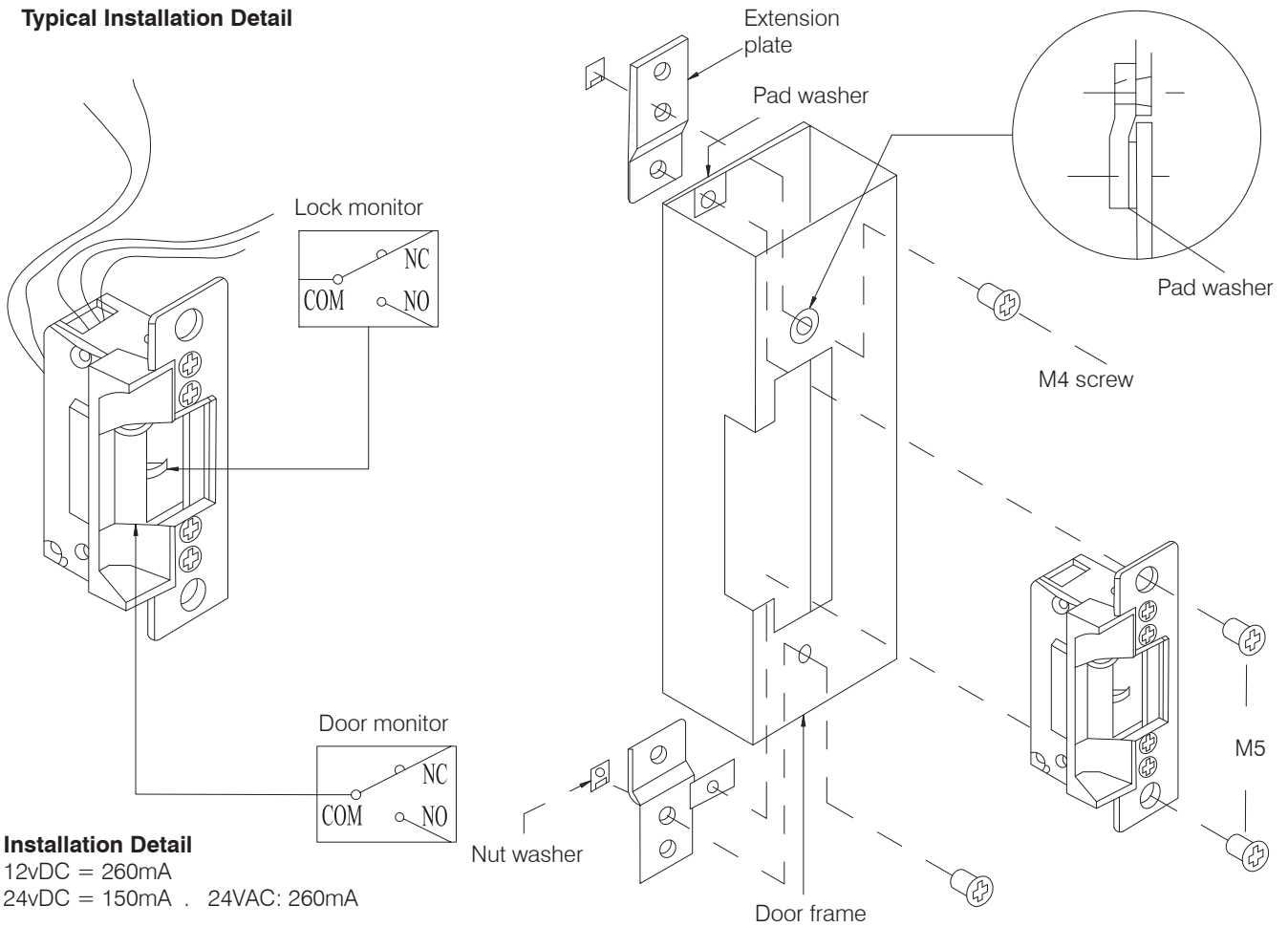

**Installation Detail**

12vDC = 260mA  
 24vDC = 150mA . 24VAC: 260mA

**Extension Lip Mounting Installation**

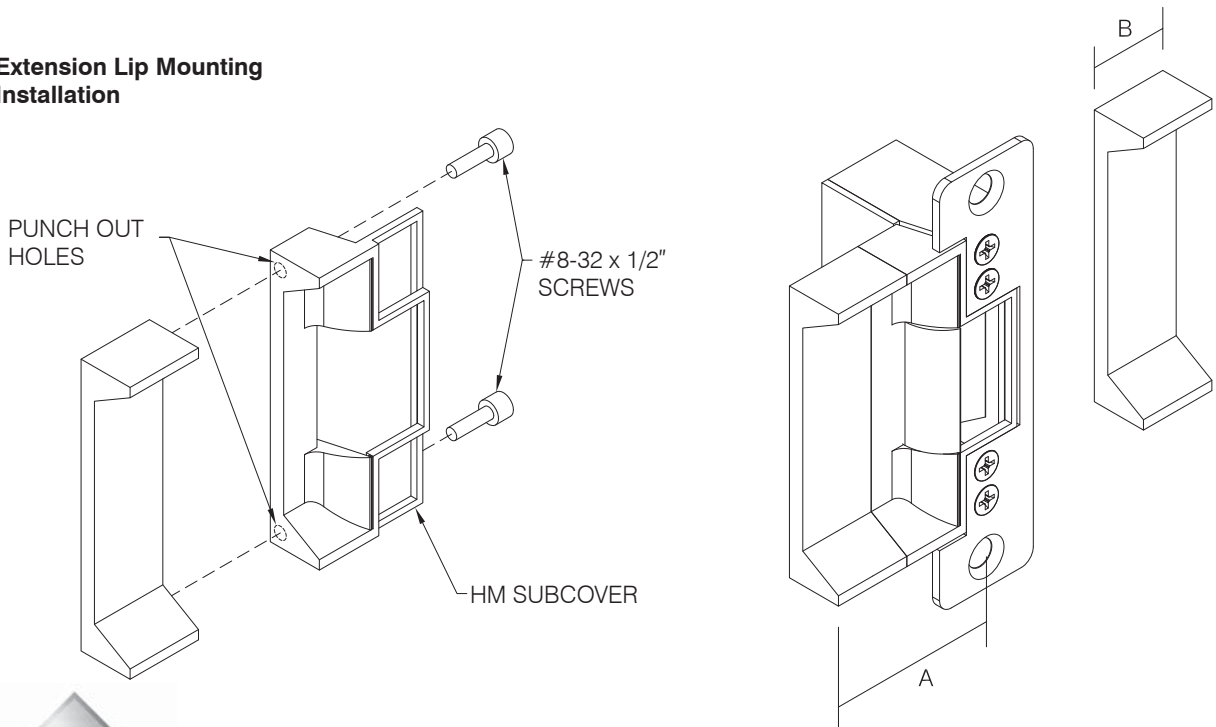

**The Parkside Group Ltd**

The Willow Centre  
 17 Willow Lane, Mitcham, Surrey, CR4 4NX  
 Tel: 020-8685 9685 Fax: 020-8646 5096  
 Email: axim@parksidegroup.co.uk  
 Web Site: www.axim.co.uk

SCALE	NTS @A4
DATE	AUGUST 2017

For scaled technical or CAD drawings, please contact AXIM.

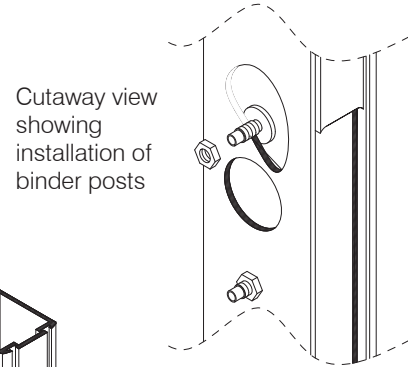
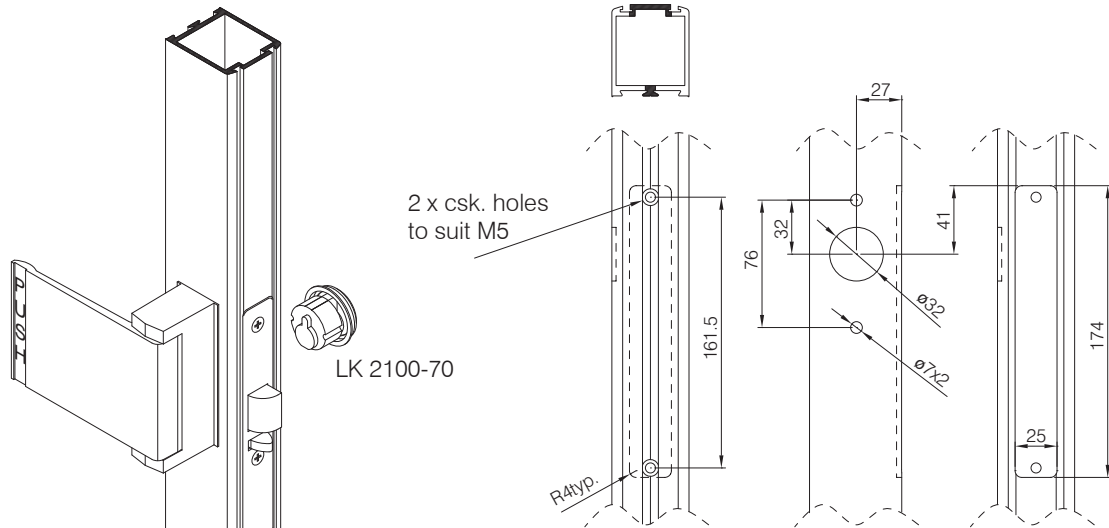

- Complete assembly consisting of:-
- PH2100 Paddle handle
  - LK2100-40RH Body dead latch
  - AC021 Lock pillar
  - LK2100-41/42 Cover plate
  - FX079SLF M5 fixing screws
  - LK2100-70 Rim cylinder (optional)

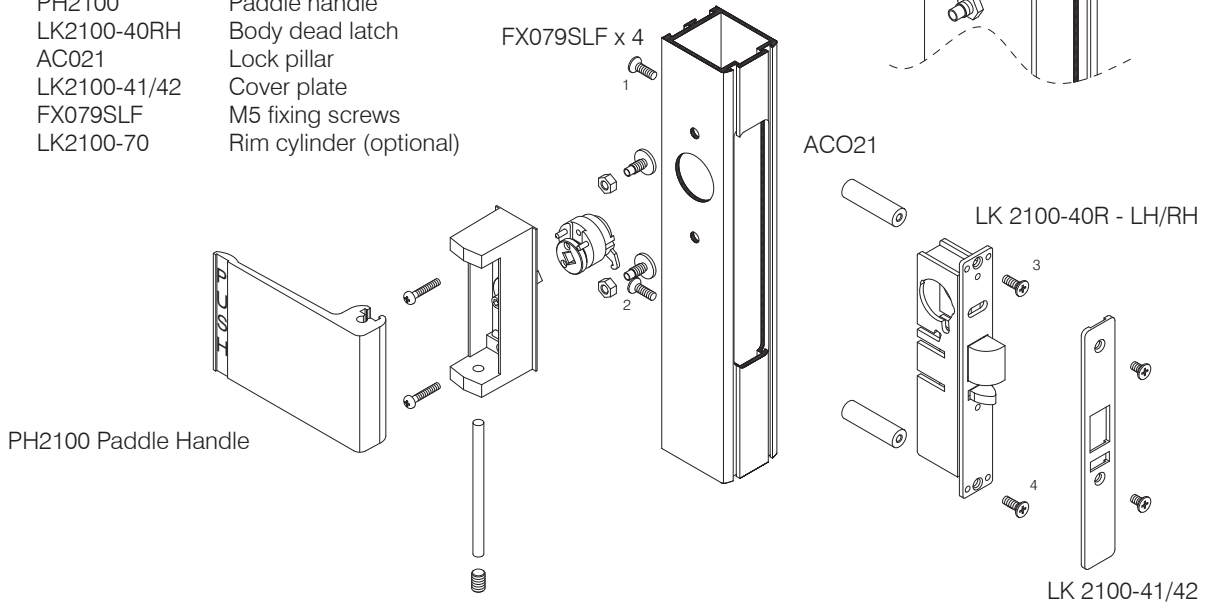

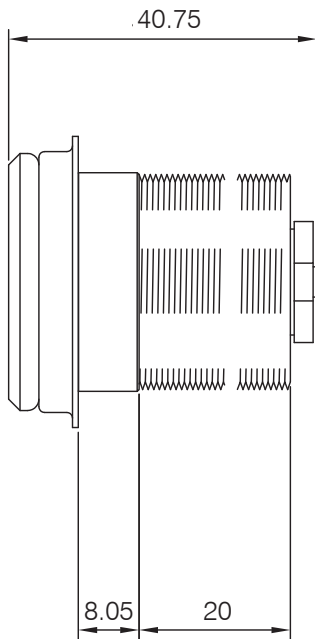

LK 2100-75

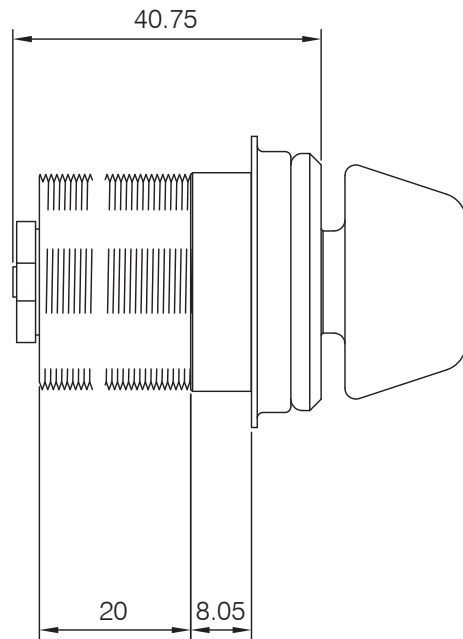

LK 2100-76

LP-500 LETTER PLATE

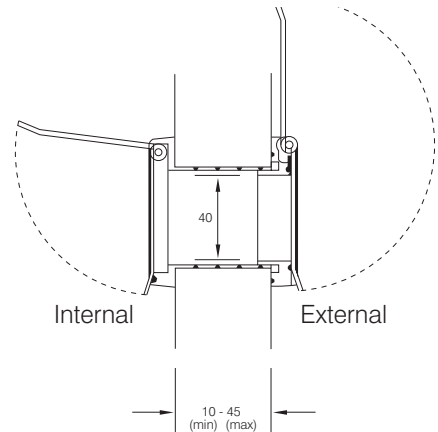
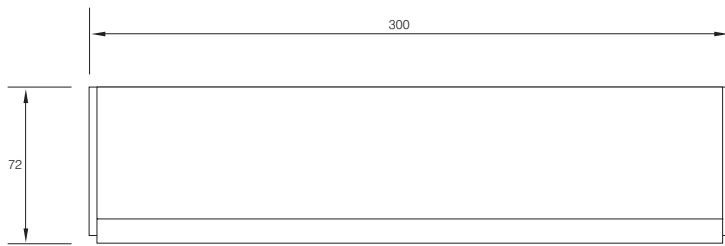

- |   |           |
|---|-----------|
| Letter plate assembly mill finish           | LP-500-ML |
| Letter plate assembly S.A.A finish          | LP-500-AL |
| Letter plate assembly Bronze 547 finish     | LP-500-DU |
| Letter plate assembly Black Anodised finish | LP-500-BK |
| Letter plate assembly White P.C.C finish    | LP-500-WT |
| Letter flap set stainless steel anodised    | LP-500-SS |

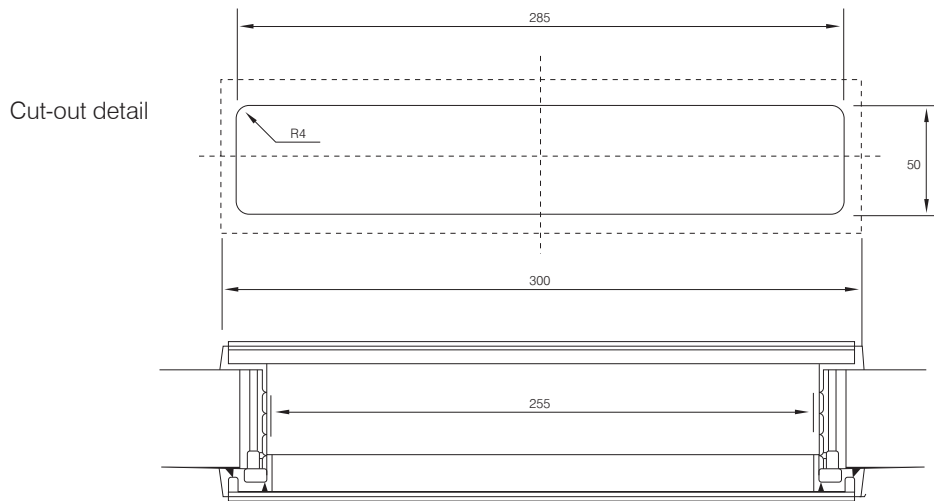

EX-570 LETTER PLATE EXTENSION SLEEVE

Letter plate extension sleeve EX-570 supplied with 2 No. Spring Clips and 120mm Fixing Screws.

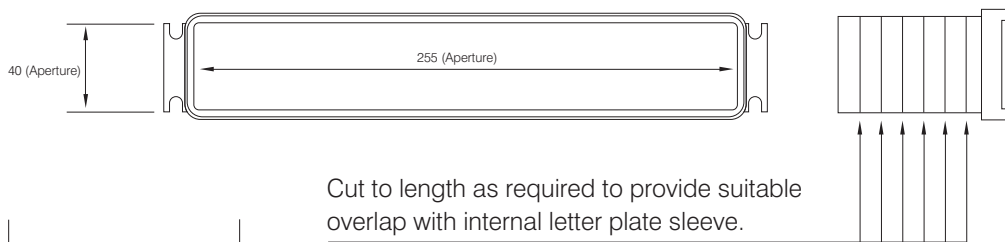

Cut to length as required to provide suitable overlap with internal letter plate sleeve.

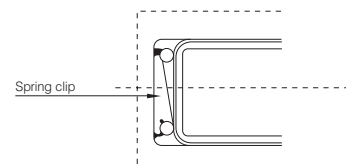
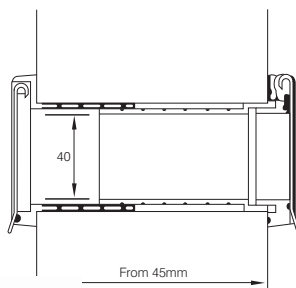

**The Parkside Group Ltd**

The Willow Centre  
17 Willow Lane, Mitcham, Surrey, CR4 4NX  
Tel: 020-8685 9685 Fax: 020-8646 5096  
Email: axim@parksidegroup.co.uk  
Web Site: www.axim.co.uk

SCALE NTS @A4

DATE MARCH 2014

For scaled technical or CAD drawings,  
please contact AXIM.

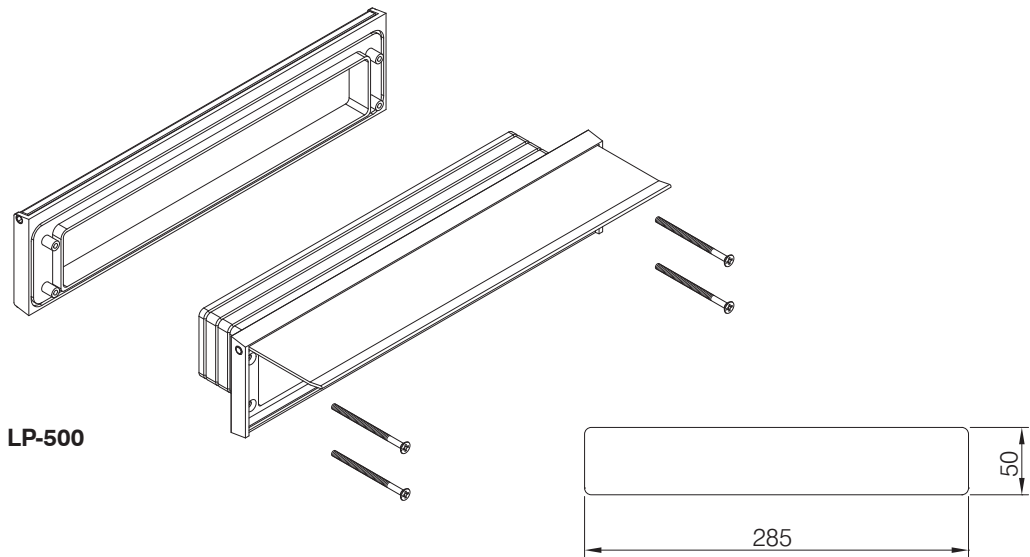
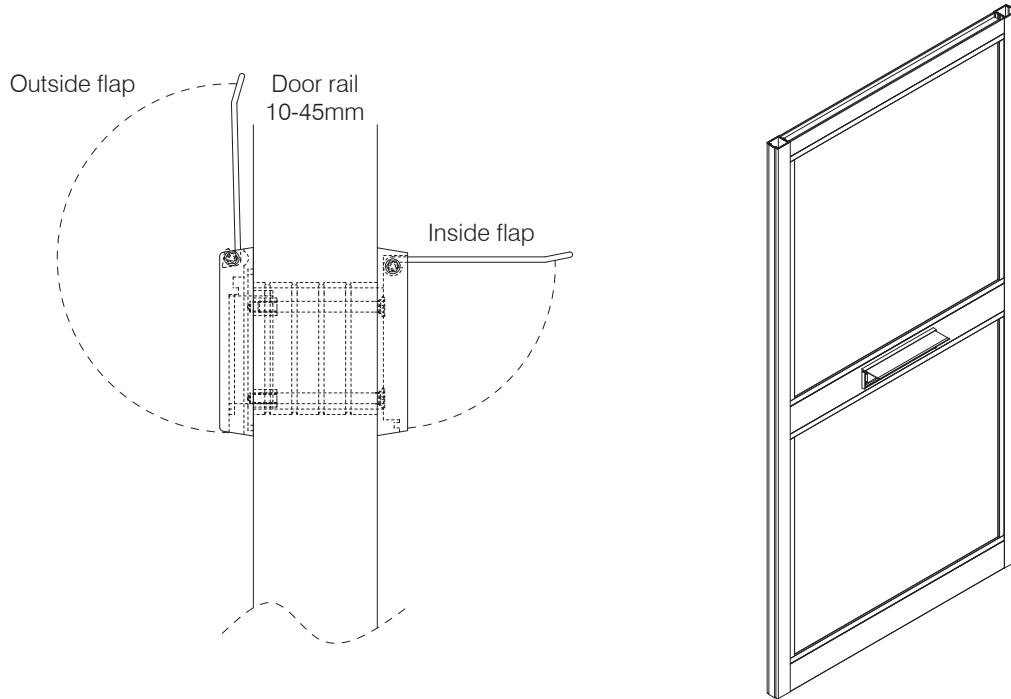

Rail preparation:  
285 x 50mm cut out  
\*No fixing holes necessary\*



**The Parkside Group Ltd**

The Willow Centre  
17 Willow Lane, Mitcham, Surrey, CR4 4NX  
Tel: 020-8685 9685 Fax: 020-8646 5096  
Email: [axim@parksidegroup.co.uk](mailto:axim@parksidegroup.co.uk)  
Web Site: [www.axim.co.uk](http://www.axim.co.uk)

SCALE	NTS @A4
DATE	MARCH 2014

For scaled technical or CAD drawings,  
please contact AXIM.

Door rail/wall up to 120mm  
(For deeper applications consult  
Comar Technical department)

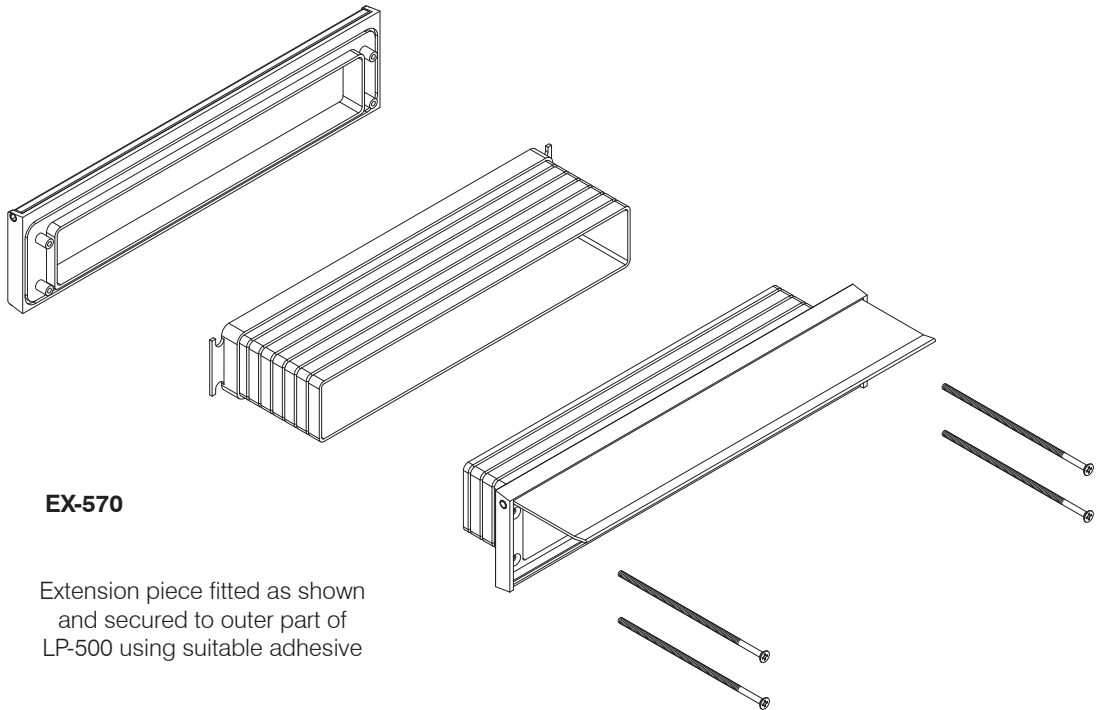
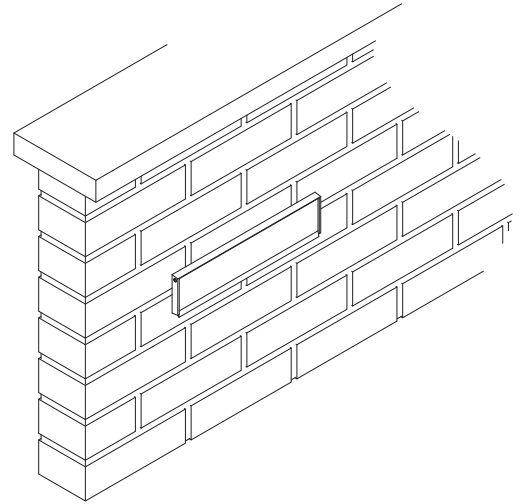
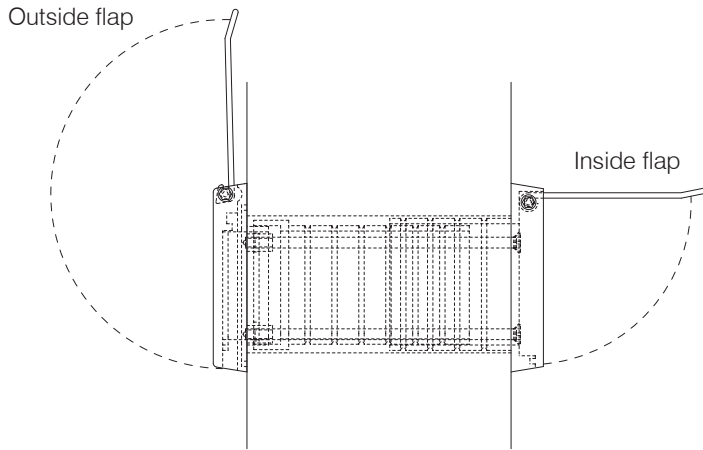

**The Parkside Group Ltd**

The Willow Centre  
17 Willow Lane, Mitcham, Surrey, CR4 4NX  
Tel: 020-8685 9685 Fax: 020-8646 5096  
Email: axim@parksidegroup.co.uk  
Web Site: www.axim.co.uk

SCALE	NTS @A4
DATE	MARCH 2014

For scaled technical or CAD drawings,  
please contact AXIM.

